

ITEM NO.	PART NUMBER	DESCRIPTION	QTY.	CUT
1	VEN-11-42-8-L36-MV-3-TBR-30K-TUBE BODY	6" ALUMINUM POST 5.5" LENGTH	1	
2	VEN-11-42-8-L36-MV-3-TBR-30K-SPUN LENS CAP	SPUN ALUMINUM 0.080"	2	
3	VEN-11-42-8-L36-MV-3-TBR-30K-FIREPLATE	ALUMINUM 0.125" PLATE	1	
4	VEN-11-42-8-L36-MV-3-TBR-30K-HEAD BASE PLATE	ALUMINUM 0.125" PLATE	1	
5	VEN-11-42-8-L36-MV-3-TBR-30K-PYRAMID CAP PLATE	ALUMINUM 0.125" PLATE	1	
6	VEN-11-42-8-L36-MV-3-TBR-30K-PYRAMID CAP	ALUMINUM 0.0635"	1	
7	VEN-11-42-8-L36-MV-3-TBR-30K-HEAD BASE	ALUMINUM 0.0635"	1	
8	VEN-11-42-8-L36-MV-3-TBR-30K-LOUVER	ALUMINUM 0.0635"	5	
9	VEN-11-42-8-L36-MV-3-TBR-30K-TUBE BRACKET	ALUMINUM 0.0635"	1	
10	VEN-11-42-8-L36-MV-3-TBR-30K-DRIVER BRACKET	ALUMINUM 0.0635"	1	
11	VEN-11-42-8-L36-MV-3-TBR-30K-THREADED ROD	3/8" THREADED ROD	4	
12	VEN-11-42-8-L36-MV-3-TBR-30K-0.500" ROUND TUBE	1/2" ALUMINUM TUBE	16	
13	VEN-11-42-8-L36-MV-3-TBR-30K-0.500" ROUND TUBE	1/2" ALUMINUM TUBE	4	
14	VEN-11-42-8-L36-MV-3-TBR-30K-0.500" ROUND TUBE	1/2" ALUMINUM TUBE	4	
15	VEN-11-42-8-L36-MV-3-TBR-30K-SQUARE TUBE	1" ALUMINUM TUBE	1	
16	VEN-11-42-8-L36-MV-3-TBR-30K-SPLBP-ACRYLIC	ACRYLIC	1	
17	ESPEN VEL29070MVH-1	DRIVER	2	
18	Alttailed_PN1011_RevB	LED	8	

UNLESS OTHERWISE SPECIFIED:

DIMENSIONS ARE IN INCHES  
 TOLERANCES:  
 FRACTIONAL ± .003  
 ANGULAR: MACH ± .01 BEND ±  
 TWO PLACE DECIMAL ±  
 THREE PLACE DECIMAL ±.001

INTERPRET GEOMETRIC  
 TOLERANCING PER:

MATERIAL

FINISH

	NAME	DATE
DRAWN		
CHECKED		
ENG APPR.		
MFG APPR.		
Q.A.		

COMMENTS:

TITLE:

VEN-11-42-8-L36-MV-3-TBR-30K

SIZE	DWG. NO.	REV
<b>A</b>	TICKET 27061	
SCALE: 1:10	WEIGHT:	SHEET 1 OF 12



ALL BEND RADIUS .030"

APPLICATION

DO NOT SCALE DRAWING

5

4

3

2

1

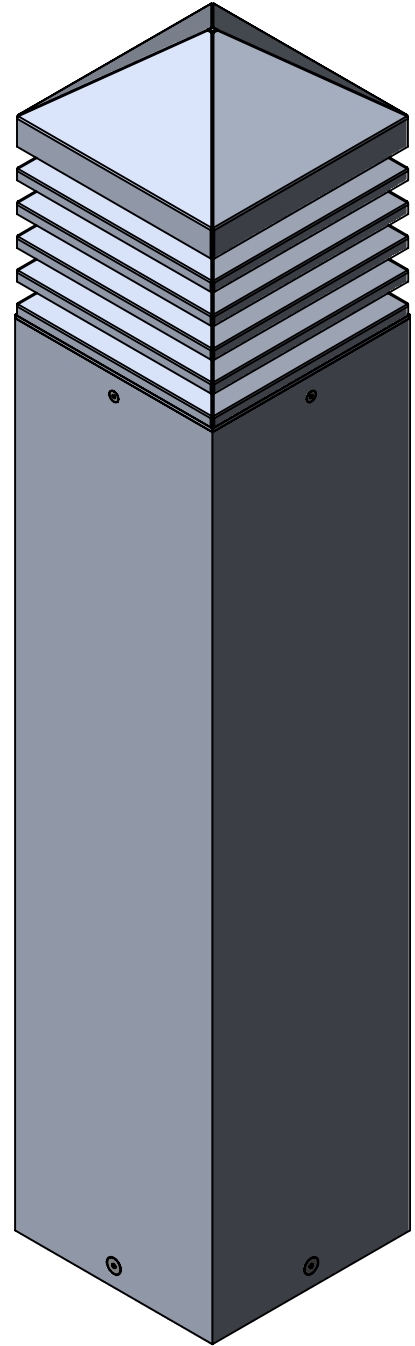
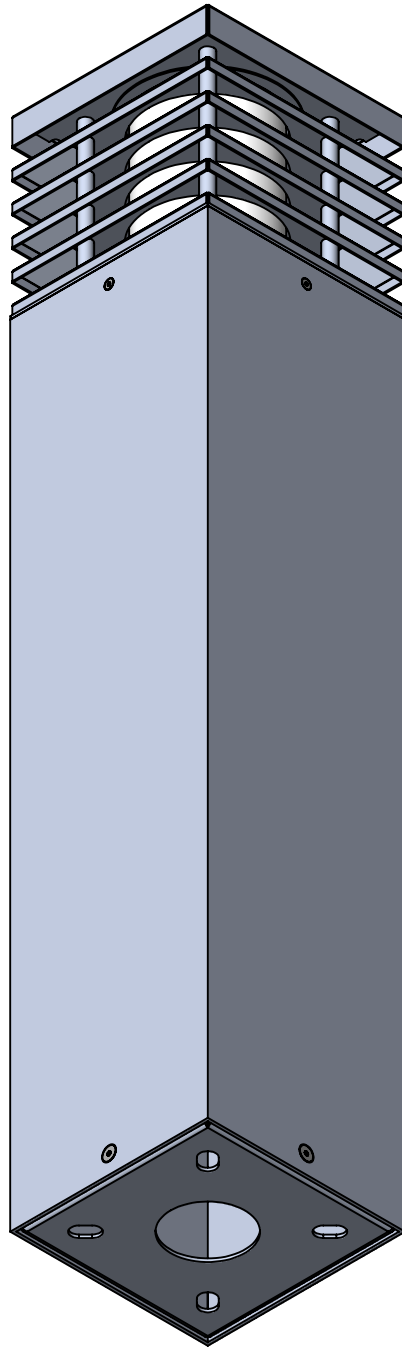
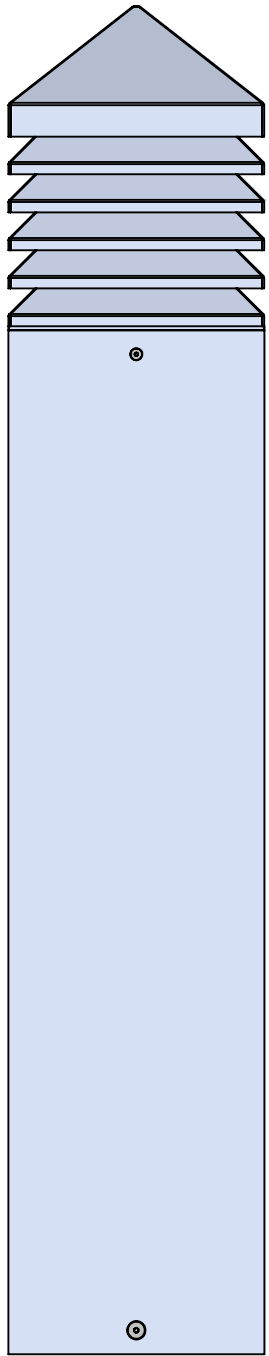

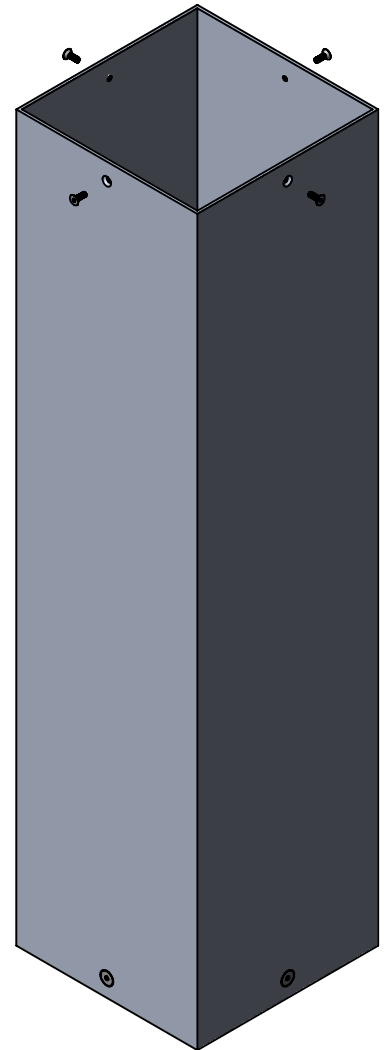
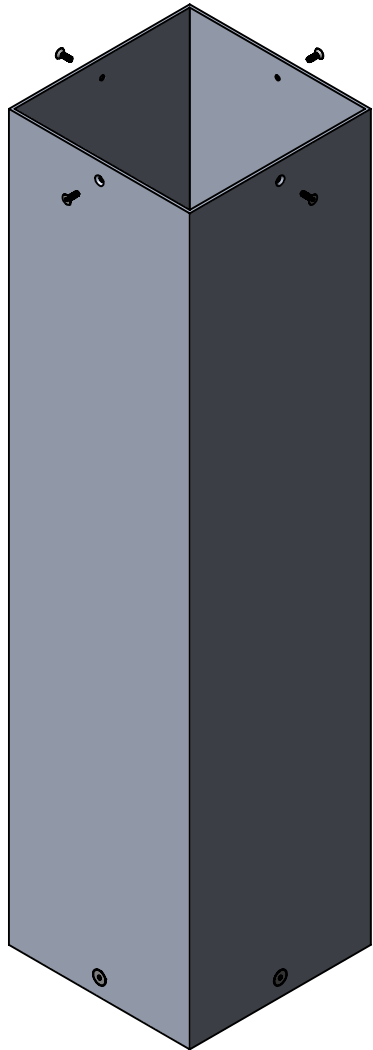
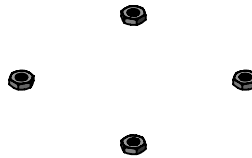
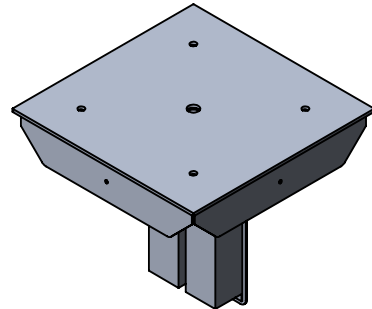
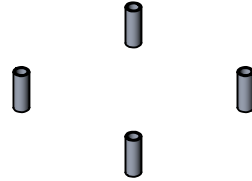
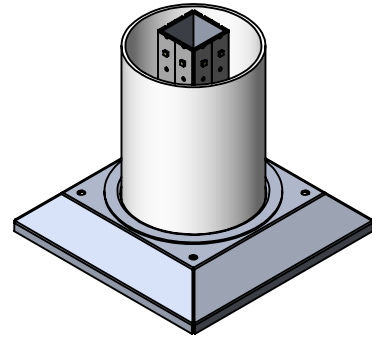
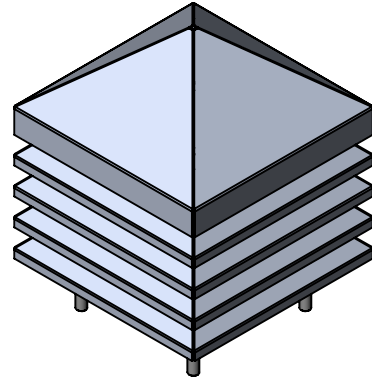
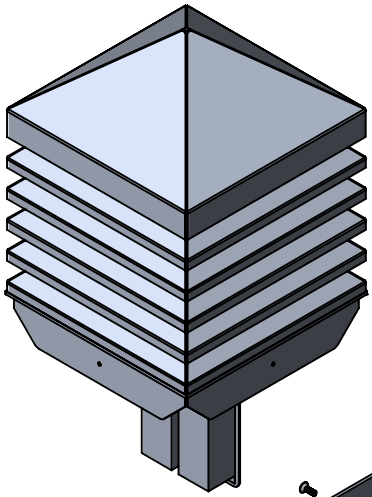

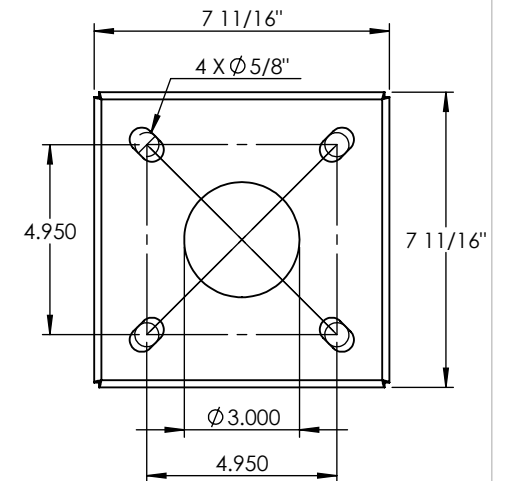
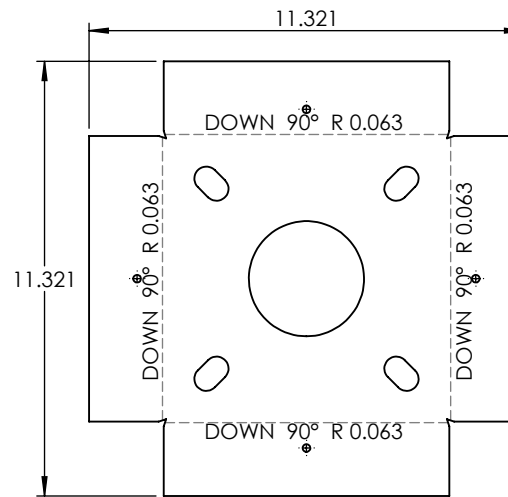
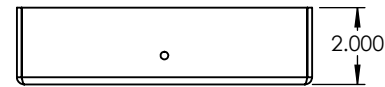
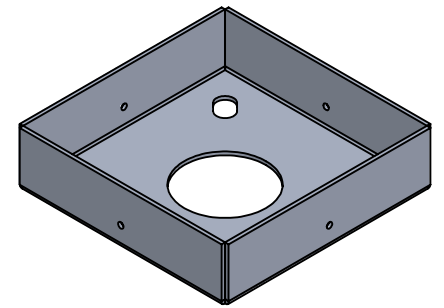
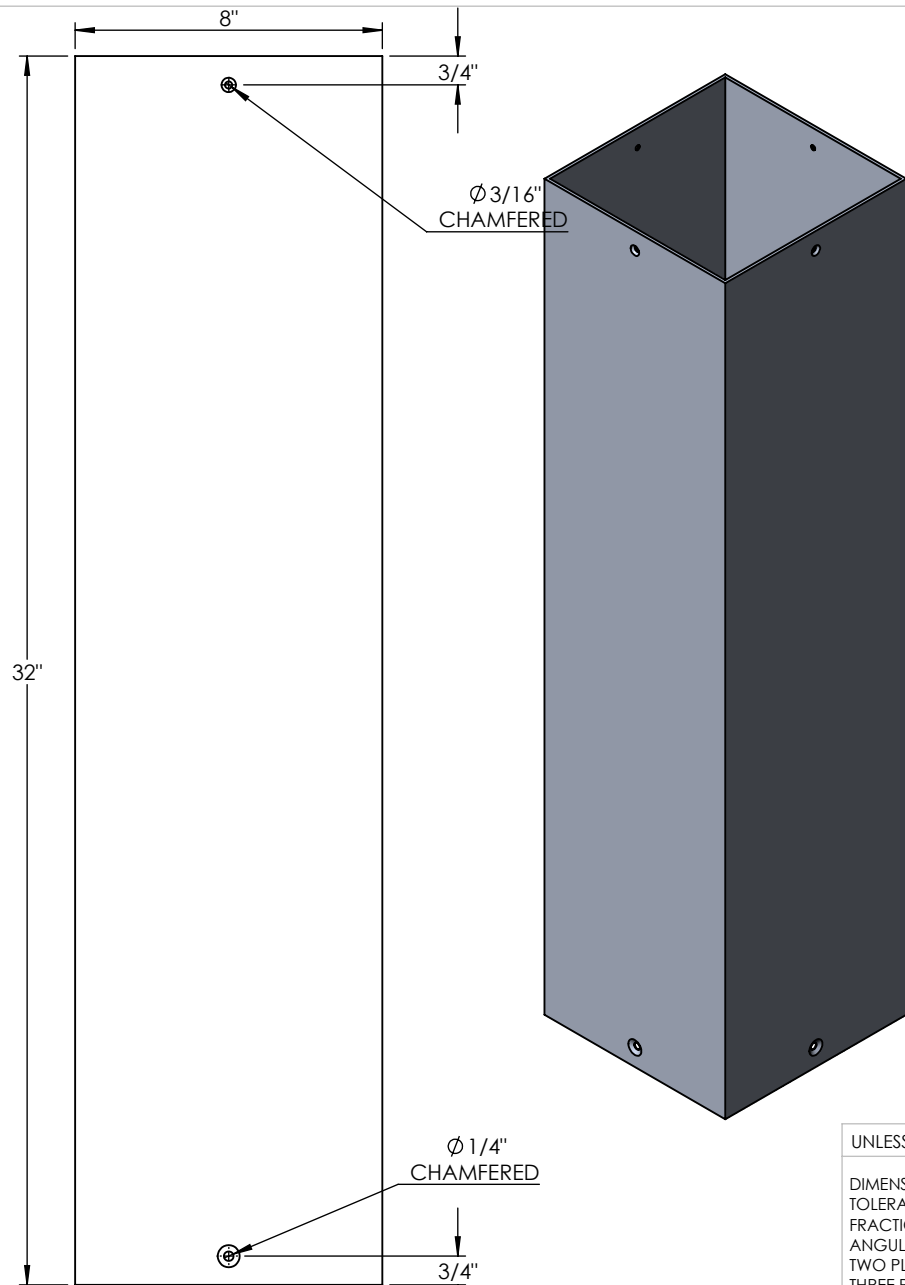

UNLESS OTHERWISE SPECIFIED:		NAME	DATE
DIMENSIONS ARE IN INCHES		DRAWN	
TOLERANCES:		CHECKED	
FRACTIONAL ±		ENG APPR.	
ANGULAR: MACH ± BEND ±		MFG APPR.	
TWO PLACE DECIMAL ±		Q.A.	
THREE PLACE DECIMAL ±		COMMENTS:	
INTERPRET GEOMETRIC TOLERANCING PER:			
MATERIAL			
FINISH			

6" ALUMINUM POST 5.5" LENGTH

TITLE:

VEN-11-42-8-L36-MV-3-TBR-30K

SIZE	DWG. NO.	REV
<b>A</b>		

SCALE: 1:5 WEIGHT: SHEET 4 OF 12

**PROPRIETARY AND CONFIDENTIAL**  
 THE INFORMATION CONTAINED IN THIS DRAWING IS THE SOLE PROPERTY OF <INSERT COMPANY NAME HERE>. ANY REPRODUCTION IN PART OR AS A WHOLE WITHOUT THE WRITTEN PERMISSION OF <INSERT COMPANY NAME HERE> IS PROHIBITED.

NEXT ASSY	USED ON
APPLICATION	

DO NOT SCALE DRAWING

5

4

3

2

1

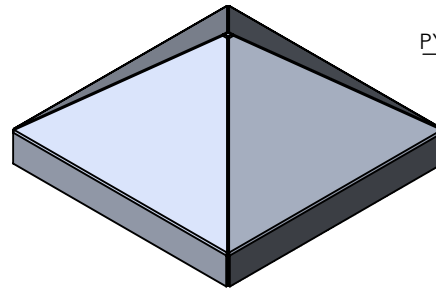
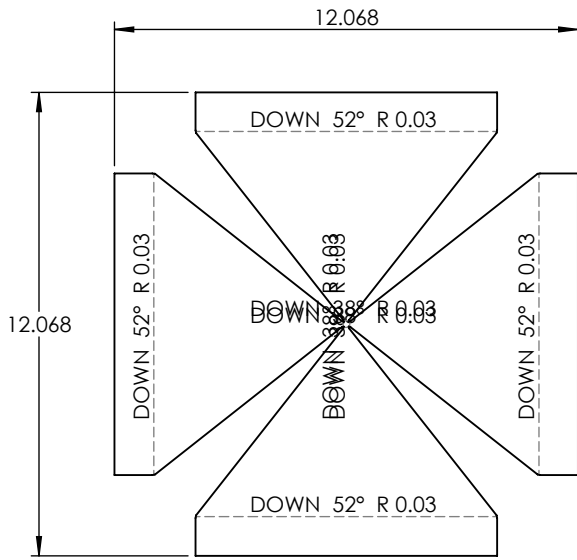

PYRAMID CAP AND CAP PLATE WELDED

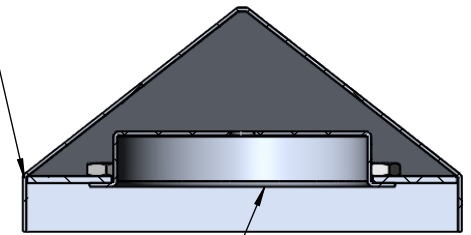

SPUN LENS CAP WELDED TO PLATE

SECTION A-A  
SCALE 1 : 3.5

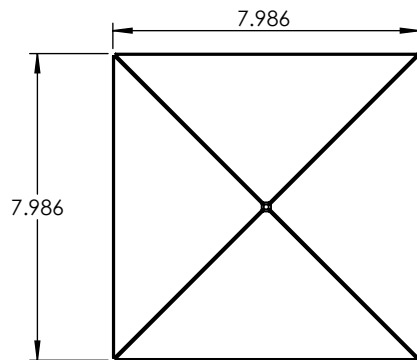
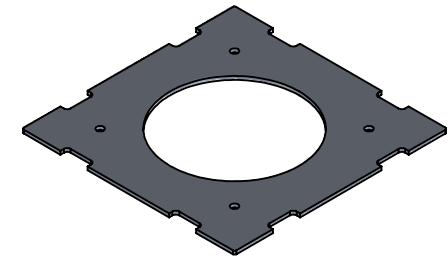
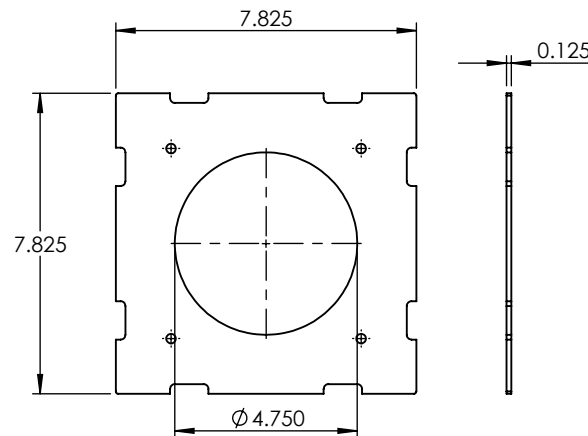
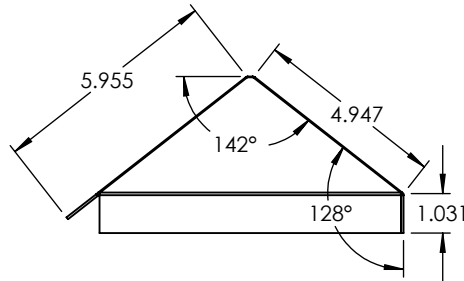
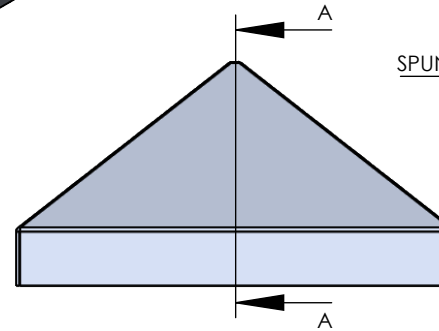

UNLESS OTHERWISE SPECIFIED:

DIMENSIONS ARE IN INCHES  
TOLERANCES:  
FRACTIONAL ±  
ANGULAR: MACH ± BEND ±  
TWO PLACE DECIMAL ±  
THREE PLACE DECIMAL ±

INTERPRET GEOMETRIC  
TOLERANCING PER:

MATERIAL

FINISH

NAME

DATE

DRAWN

CHECKED

ENG APPR.

MFG APPR.

Q.A.

COMMENTS:

ALUMINUM 0.0635"

TITLE:

VEN-11-42-8-L36-MV-3-TBR-30K

SIZE  
**A**

DWG. NO.

REV

SCALE: 1:5

WEIGHT:

SHEET 5 OF 12

**PROPRIETARY AND CONFIDENTIAL**  
THE INFORMATION CONTAINED IN THIS  
DRAWING IS THE SOLE PROPERTY OF  
<INSERT COMPANY NAME HERE>. ANY  
REPRODUCTION IN PART OR AS A WHOLE  
WITHOUT THE WRITTEN PERMISSION OF  
<INSERT COMPANY NAME HERE> IS  
PROHIBITED.

NEXT ASSY	USED ON
APPLICATION	

DO NOT SCALE DRAWING
----------------------

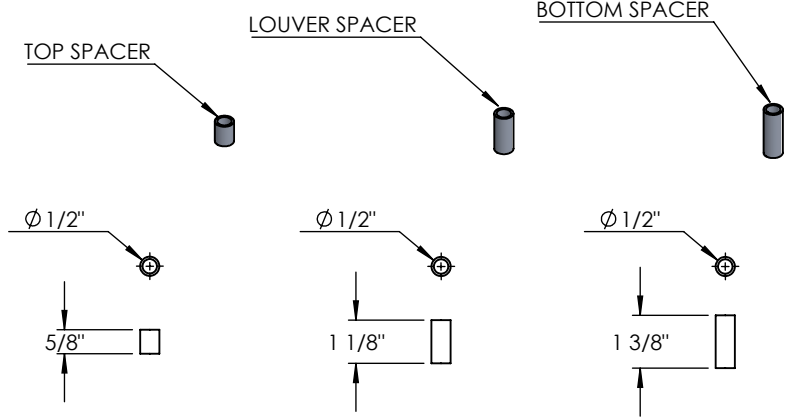
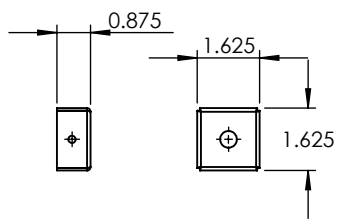
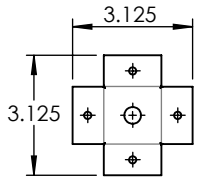
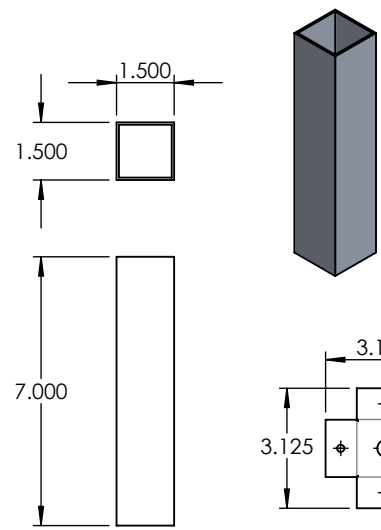
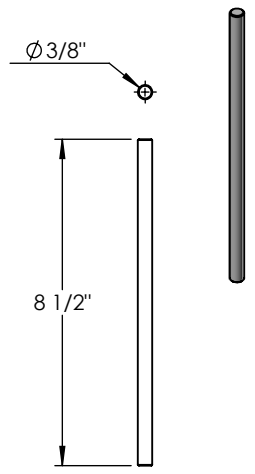
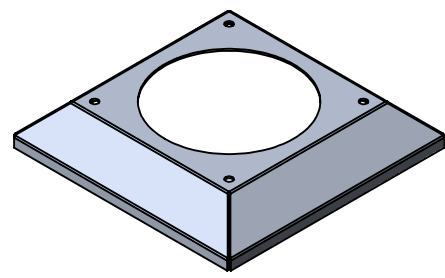
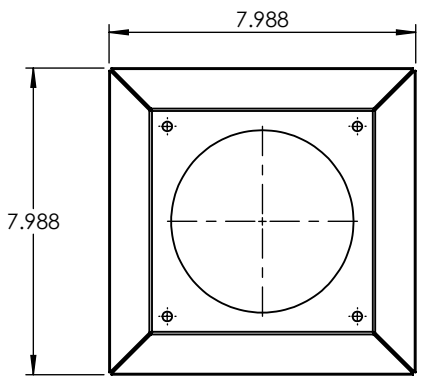
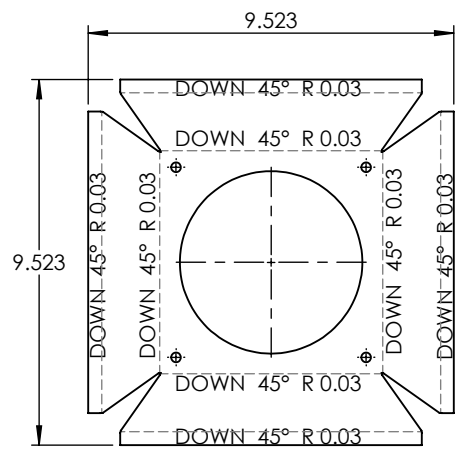
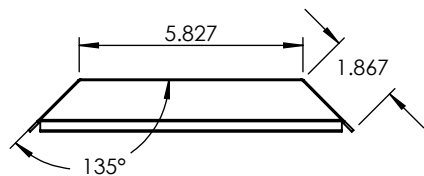
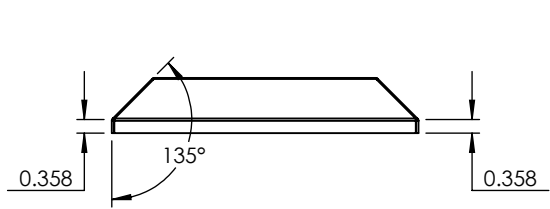

UNLESS OTHERWISE SPECIFIED:  
 DIMENSIONS ARE IN INCHES  
 TOLERANCES:  
 FRACTIONAL ±  
 ANGULAR: MACH ± BEND ±  
 TWO PLACE DECIMAL ±  
 THREE PLACE DECIMAL ±

INTERPRET GEOMETRIC TOLERANCING PER:  
 MATERIAL  
 FINISH  
 APPLICATION  
 USED ON  
 DO NOT SCALE DRAWING

	NAME	DATE
DRAWN		
CHECKED		
ENG APPR.		
MFG APPR.		
Q.A.		

COMMENTS:

ALUMINUM 0.0635"		
TITLE: VEN-11-42-8-L36-MV-3-TBR-30K		
SIZE <b>A</b>	DWG. NO.	REV
SCALE: 1:5	WEIGHT:	SHEET 6 OF 12

**PROPRIETARY AND CONFIDENTIAL**  
 THE INFORMATION CONTAINED IN THIS DRAWING IS THE SOLE PROPERTY OF <INSERT COMPANY NAME HERE>. ANY REPRODUCTION IN PART OR AS A WHOLE WITHOUT THE WRITTEN PERMISSION OF <INSERT COMPANY NAME HERE> IS PROHIBITED.

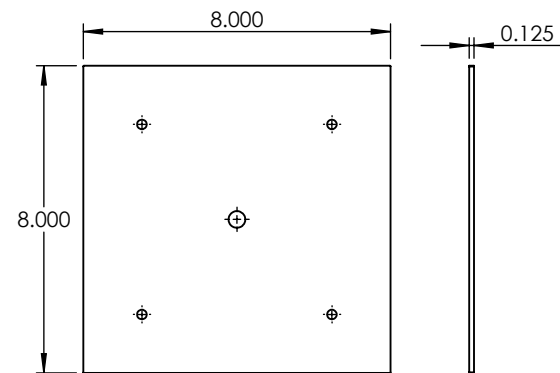
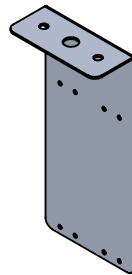
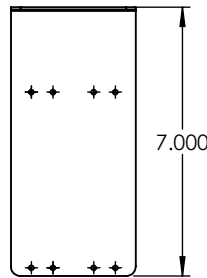
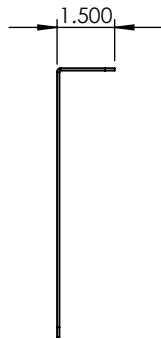
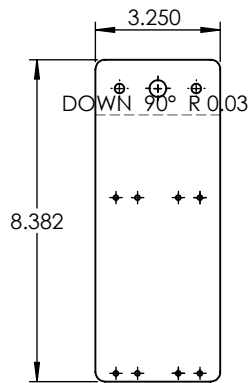
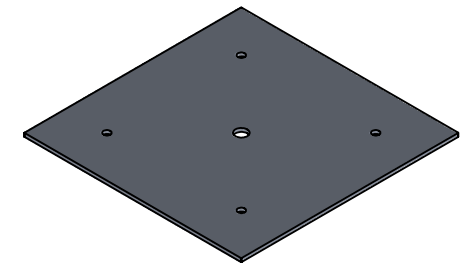
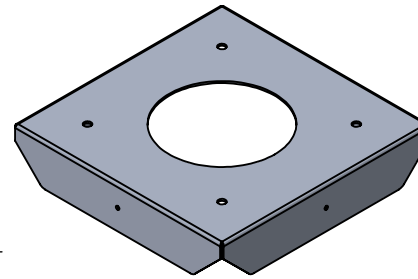
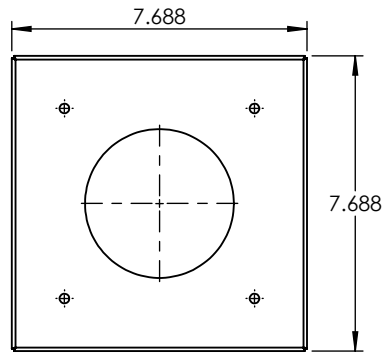
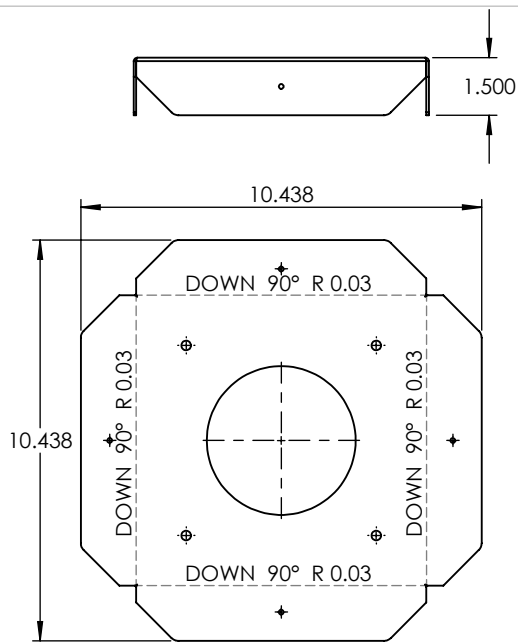

UNLESS OTHERWISE SPECIFIED:		NAME	DATE	ALUMINUM 0.0635"		
DIMENSIONS ARE IN INCHES TOLERANCES: FRACTIONAL ± ANGULAR: MACH ± BEND ± TWO PLACE DECIMAL ± THREE PLACE DECIMAL ±		DRAWN				TITLE:
INTERPRET GEOMETRIC TOLERANCING PER:		CHECKED		VEN-11-42-8-L36-MV-3-TBR-30K		
MATERIAL		ENG APPR.				
FINISH		MFG APPR.		SIZE	DWG. NO.	REV
NEXT ASSY		Q.A.		<b>A</b>		
USED ON		COMMENTS:				
APPLICATION		DO NOT SCALE DRAWING		SCALE: 1:5	WEIGHT:	SHEET 7 OF 12

**PROPRIETARY AND CONFIDENTIAL**  
THE INFORMATION CONTAINED IN THIS DRAWING IS THE SOLE PROPERTY OF <INSERT COMPANY NAME HERE>. ANY REPRODUCTION IN PART OR AS A WHOLE WITHOUT THE WRITTEN PERMISSION OF <INSERT COMPANY NAME HERE> IS PROHIBITED.

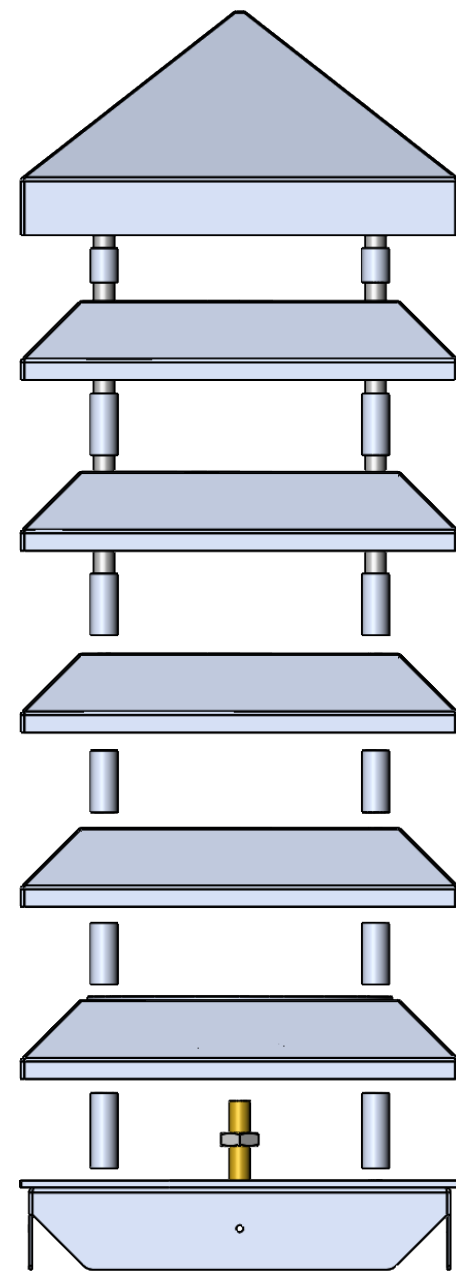
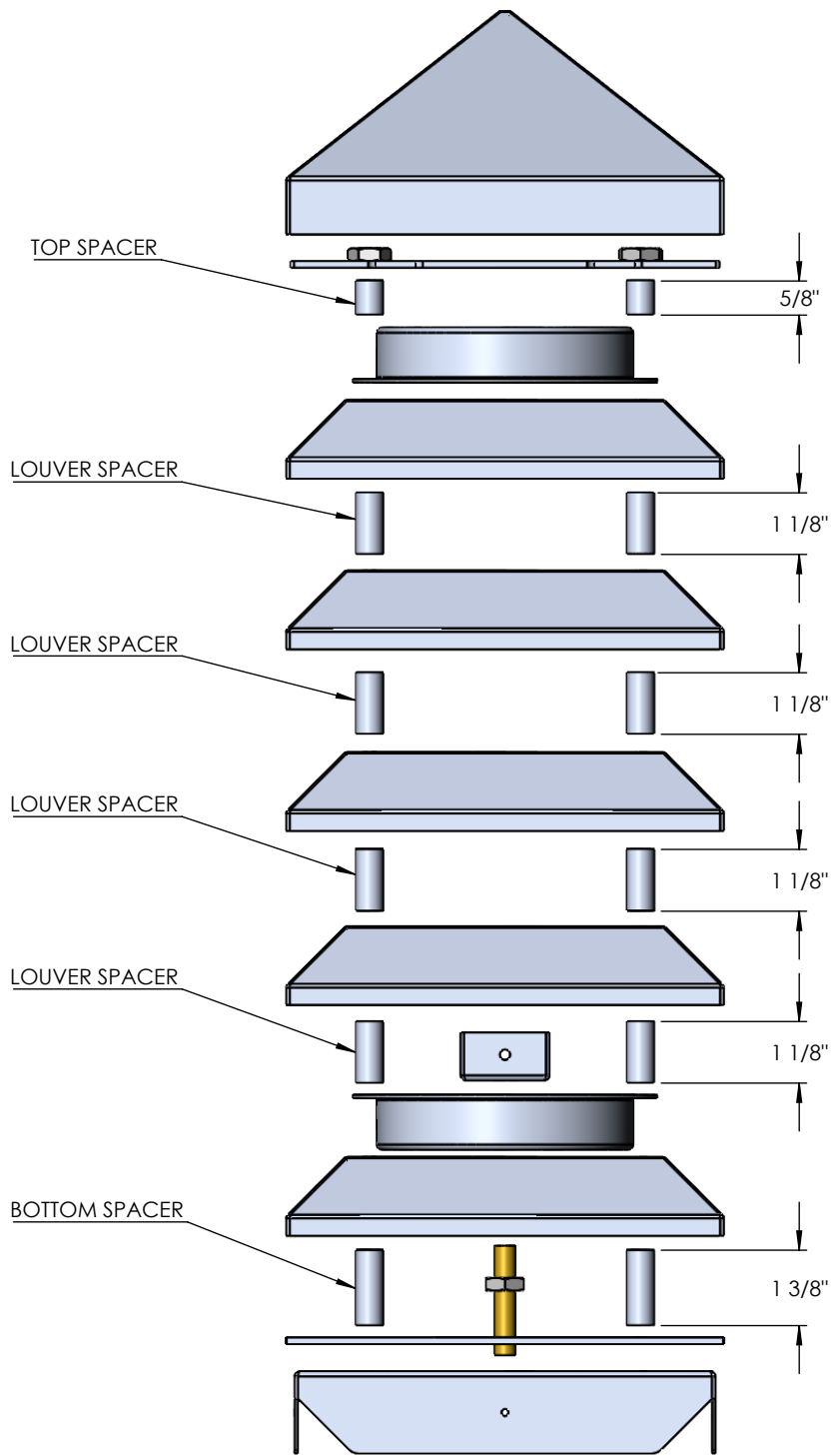



**ALL CAP EDGES NEED TO BE WELDED AND CLEANED**

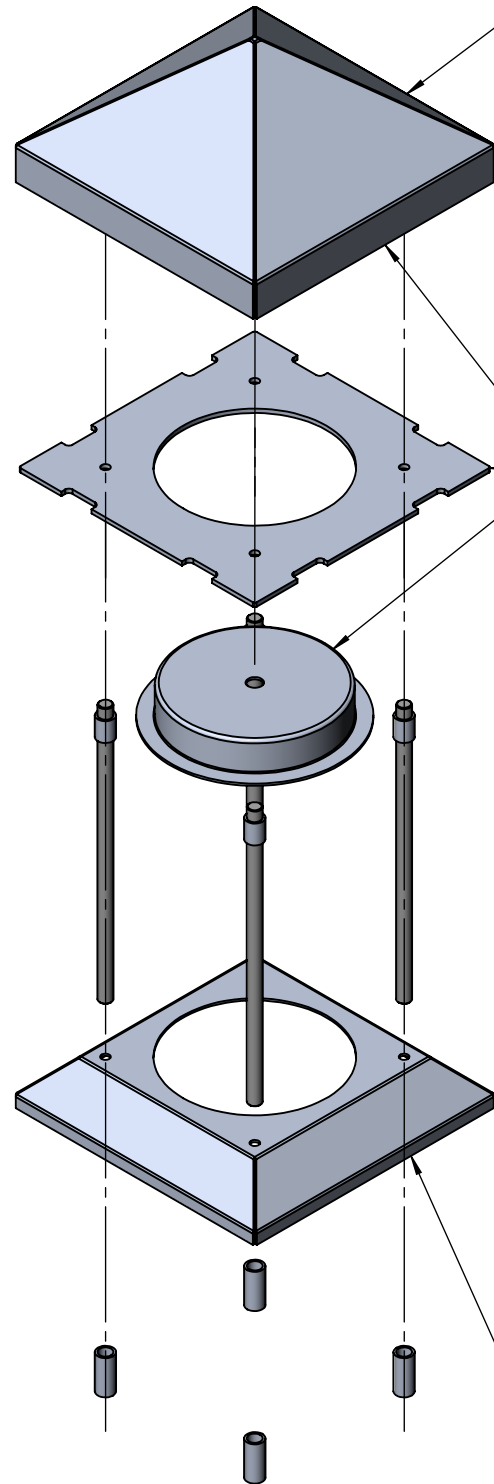
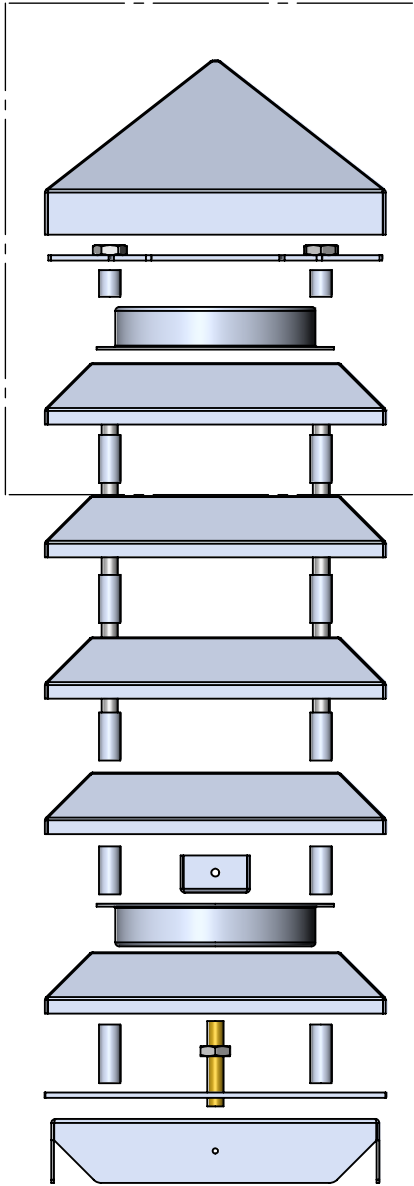

**WELDED AS ONE**

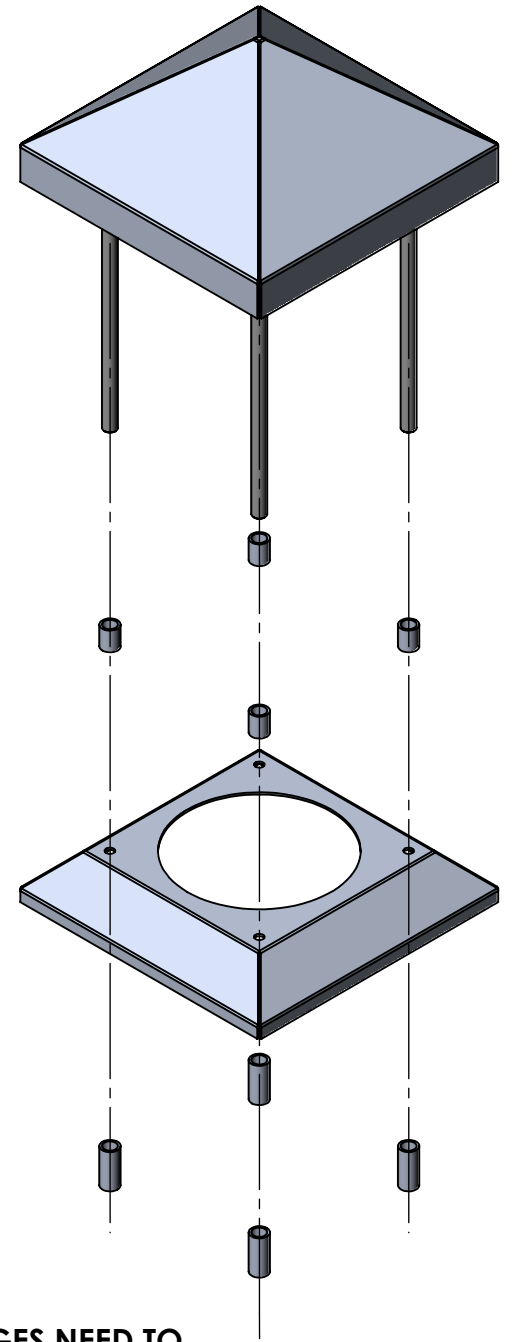

**ALL LOUVER EDGES NEED TO BE WELDED AND CLEANED**

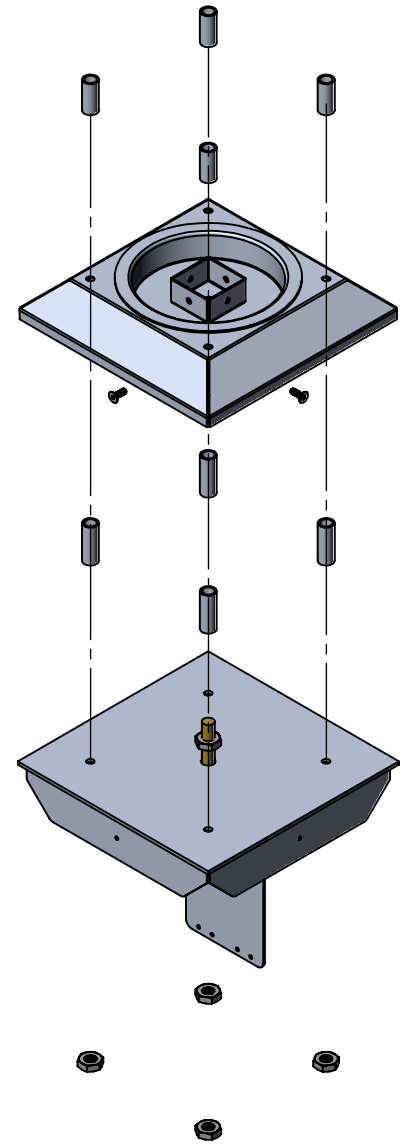
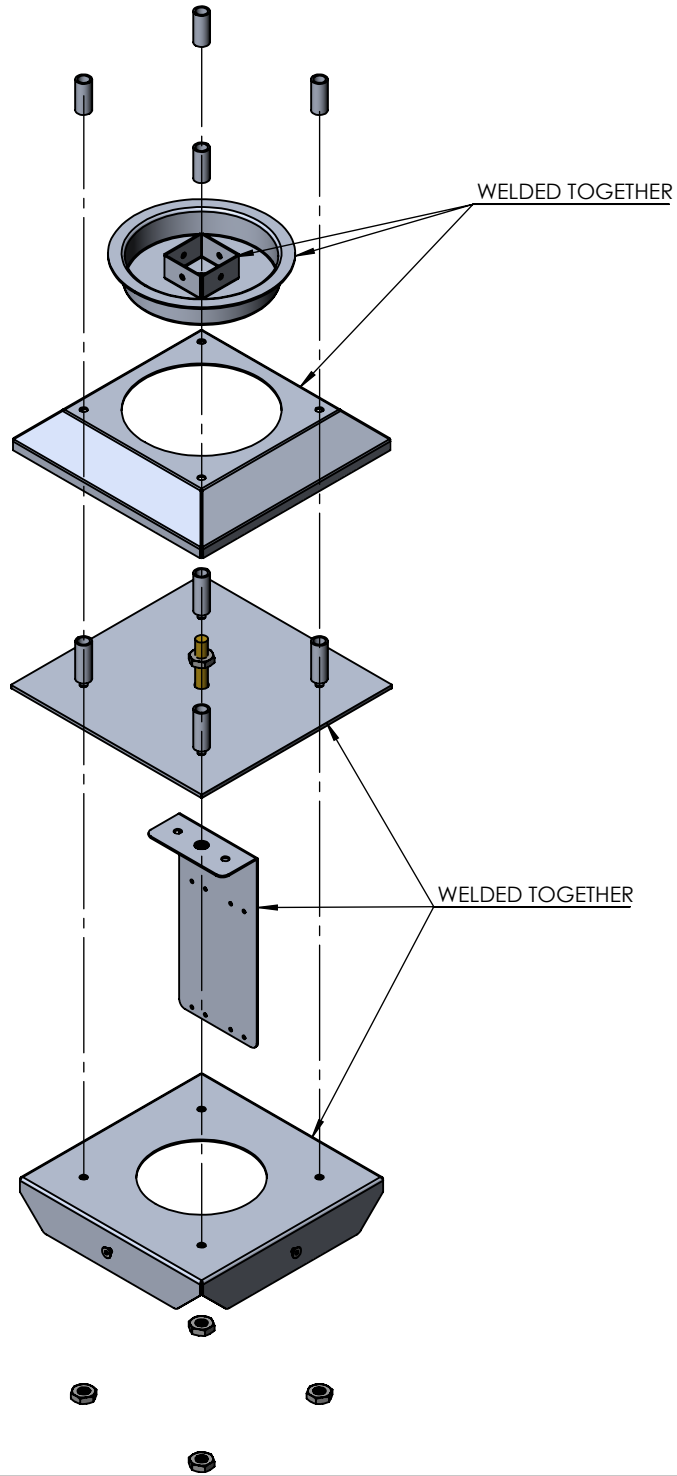
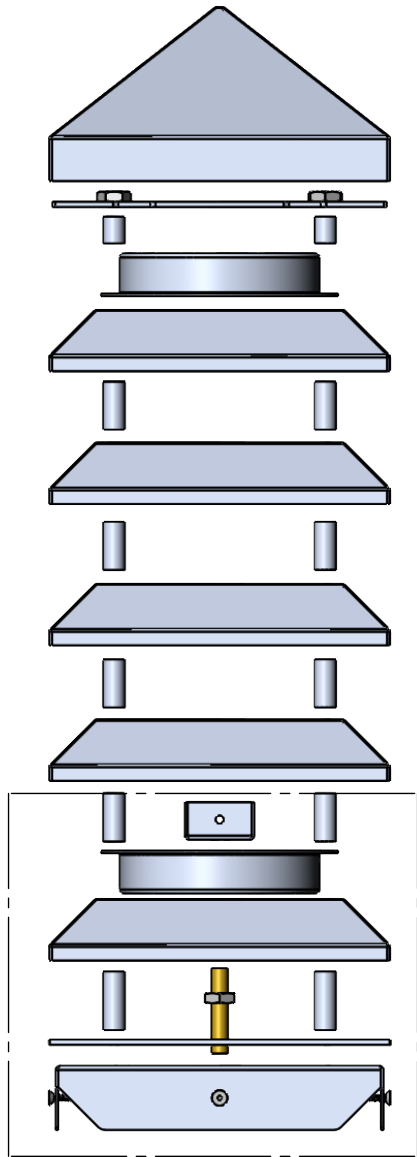

ITEM NO.	PART NUMBER	DESCRIPTION	QTY.
1	VEN-11-42-8-L36-MV-3-TBR-30K-SPUN LENS CAP	SPUN ALUMINUM 0.080"	1

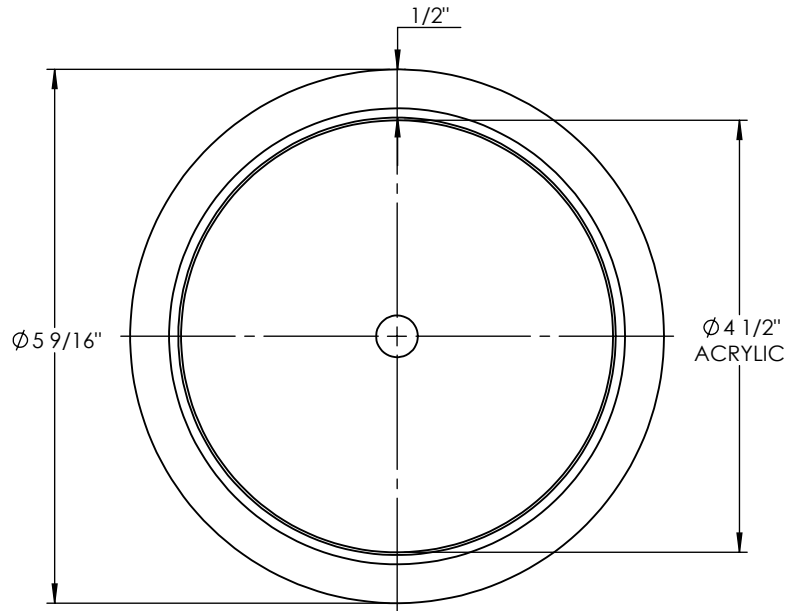
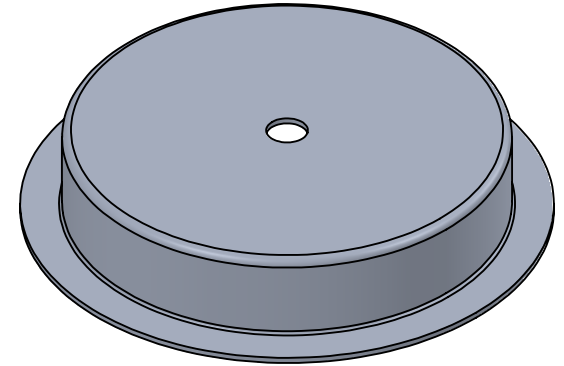
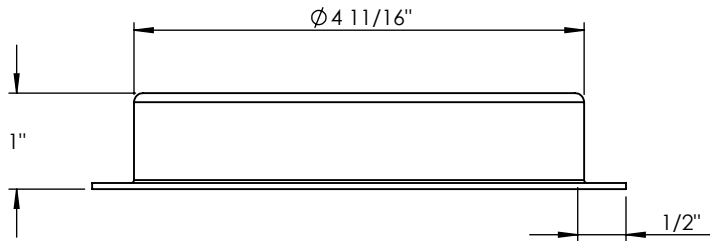

**PROPRIETARY AND CONFIDENTIAL**  
 THE INFORMATION CONTAINED IN THIS DRAWING IS THE SOLE PROPERTY OF <INSERT COMPANY NAME HERE>. ANY REPRODUCTION IN PART OR AS A WHOLE WITHOUT THE WRITTEN PERMISSION OF <INSERT COMPANY NAME HERE> IS PROHIBITED.

		UNLESS OTHERWISE SPECIFIED:	NAME	DATE
		DIMENSIONS ARE IN INCHES TOLERANCES: FRACTIONAL ± ANGULAR: MACH ± BEND ± TWO PLACE DECIMAL ± THREE PLACE DECIMAL ±	DRAWN	
		INTERPRET GEOMETRIC TOLERANCING PER:	CHECKED	
		MATERIAL	ENG APPR.	
		FINISH	MFG APPR.	
			Q.A.	
			COMMENTS:	
NEXT ASSY	USED ON			
APPLICATION	DO NOT SCALE DRAWING			

SPUN ALUMINUM 0.080"		
TITLE:		
VEN-11-42-8-L36-MV-3-TBR-30K		
SIZE	DWG. NO.	REV
<b>A</b>		
SCALE: 1:2	WEIGHT:	SHEET 11 OF 12

7 11/16"

4 X  $\phi$  5/8"

4.95

$\phi$  3"

7 11/16"

4.95

**3/8" X 12" LONG  
ANCHOR BOLT SIZE**

