

ITEM NO.	PART NUMBER	DESCRIPTION	QTY.	CUT
1	BOL-DN-SQFH-36X6-20W-MN-CA-30K-POST	6"X6" POST 7.5' LENGTH	1	
2	BOL-DN-SQFH-36X6-20W-MN-CA-30K-SQUARE TUBE	ALUMINUM 0.125" PLATE	4	
3	BOL-DN-SQFH-36X6-20W-MN-CA-30K-ANCHOR BASE	ALUMINUM 0.125" PLATE	1	
4	BOL-DN-SQFH-36X6-20W-MN-CA-30K-POST CAP	ALUMINUM 0.125" PLATE	1	
5	BOL-DN-SQFH-36X6-20W-MN-CA-30K-POST FLANGE	ALUMINUM 0.250" PLATE	1	
9	BOL-DN-SQFH-36X6-20W-MN-CA-30K-CONE MOUNT PLATE	ALUMINUM 0.125" PLATE	1	
10	BOL-DN-SQFH-36X6-20W-MN-CA-30K-LED PLATE	ALUMINUM 0.125" PLATE	1	
11	BOL-DN-SQFH-36X6-20W-MN-CA-30K-SPUN CONE	SPUN ALUMINUM 0.080"	1	
12	BOL-DN-SQFH-36X6-20W-MN-CA-30K-DRIVER BRACKET	ALUMINUM 0.0635"	1	
13	BOL-DN-SQFH-36X6-20W-MN-CA-30K-SLEEVE SIDE	ALUMINUM 0.0635"	2	
14	BOL-DN-SQFH-36X6-20W-MN-CA-30K-ACRYLIC	ACRYLIC	1	
15	43 MM HEAT SINK	HEAT SINK	4	
16	FulhamThorLED_T1M1UNV035015L_120277v	DRIVER	2	
17	Altailed_PCN_D1000_105B	LED	4	

UNLESS OTHERWISE SPECIFIED:

DIMENSIONS ARE IN INCHES
 TOLERANCES:
 FRACTIONAL ± .003
 ANGULAR: MACH ± .01 BEND ±
 TWO PLACE DECIMAL ±
 THREE PLACE DECIMAL ±.001

INTERPRET GEOMETRIC
 TOLERANCING PER:

MATERIAL

FINISH

NAME DATE

DRAWN
 CHECKED
 ENG APPR.
 MFG APPR.

Q.A.
 COMMENTS:

TITLE:

BOL-DN-SQFH-36X6-20W-MN-CA-30K

SIZE DWG. NO. REV

A TICKET 27071

SCALE: 1:9 WEIGHT: SHEET 1 OF 11



ALL BEND RADIUS .030"

APPLICATION

DO NOT SCALE DRAWING

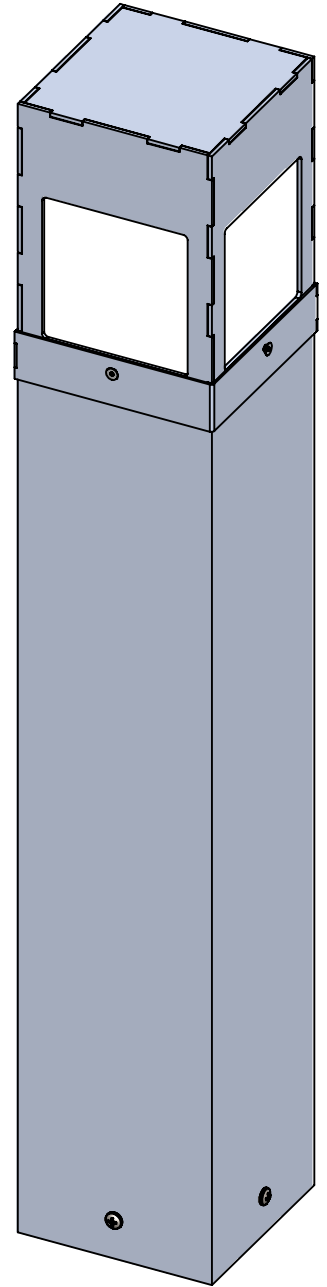
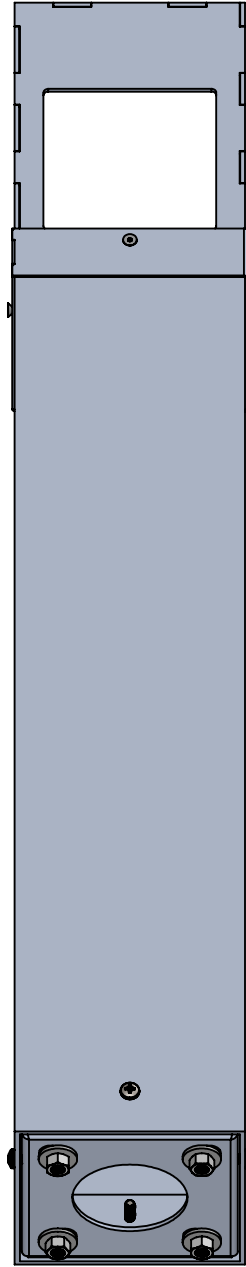
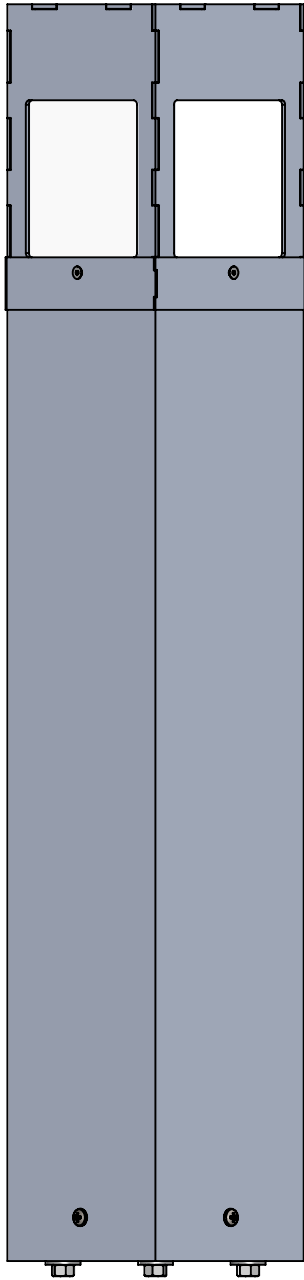

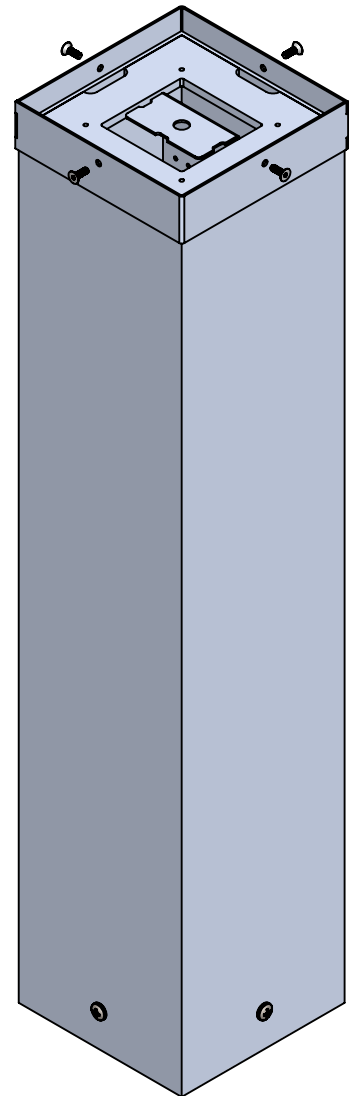
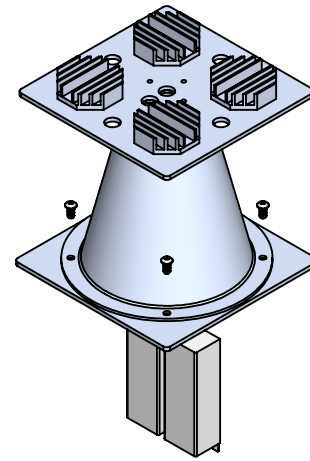
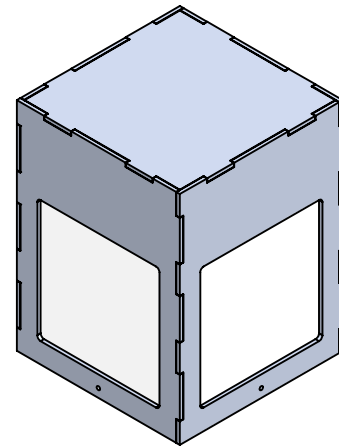
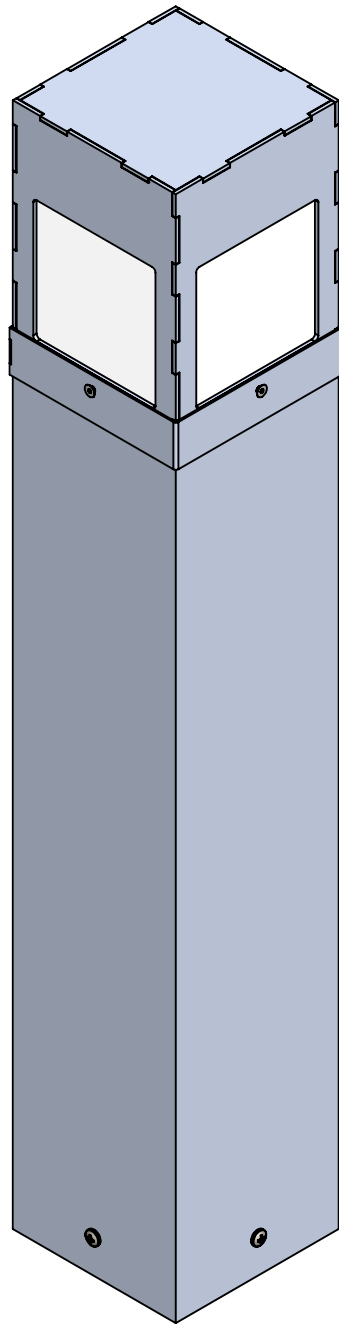
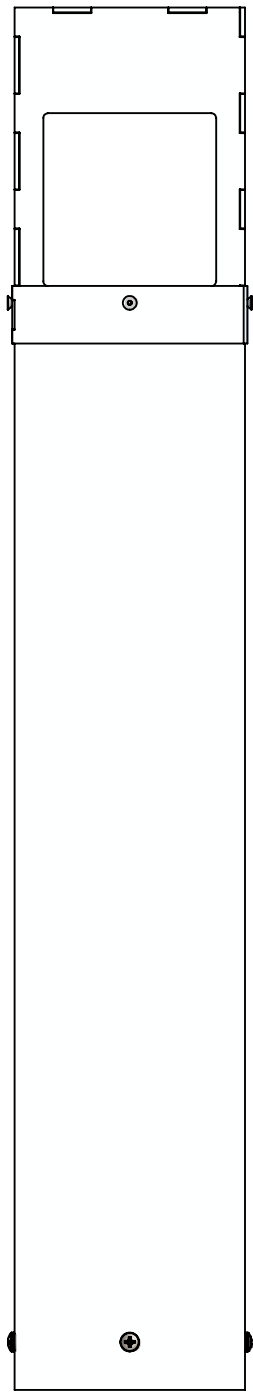
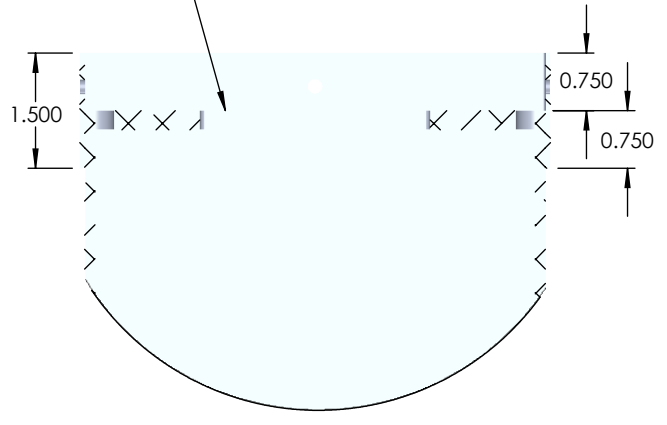
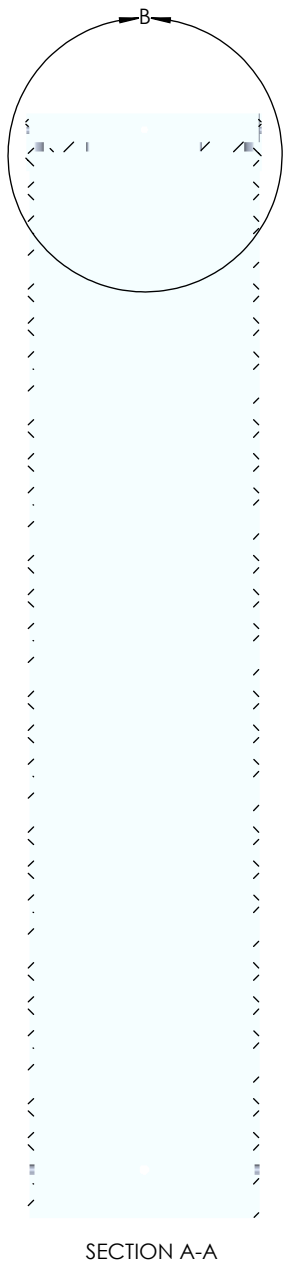
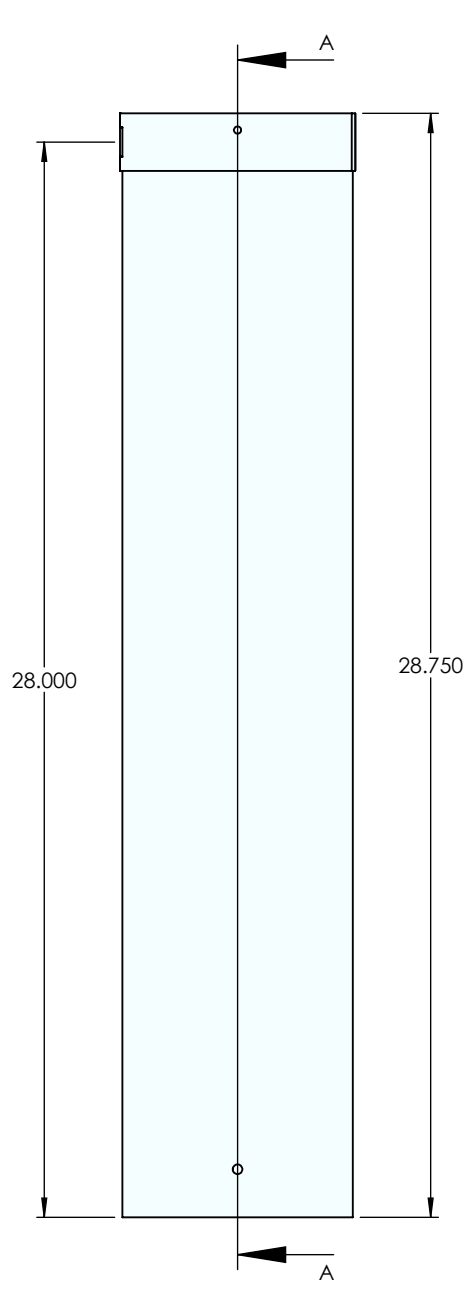
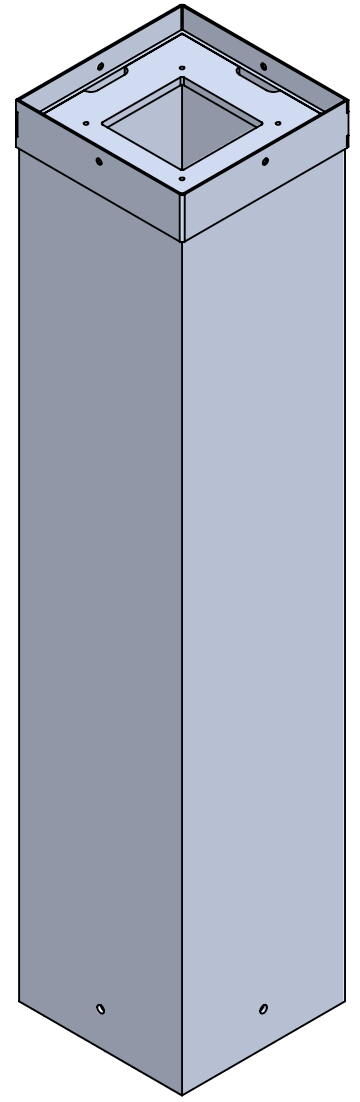
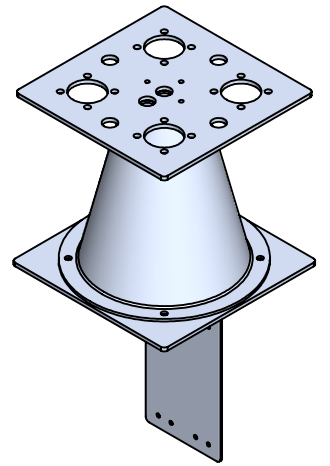
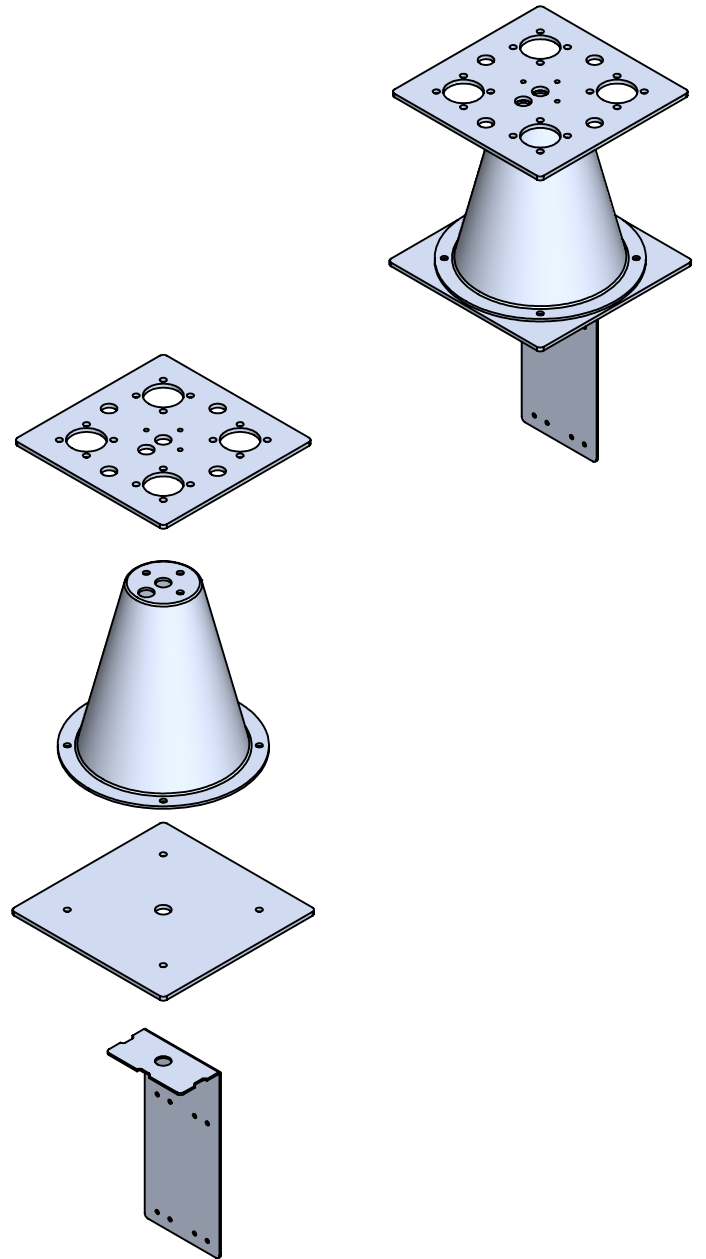
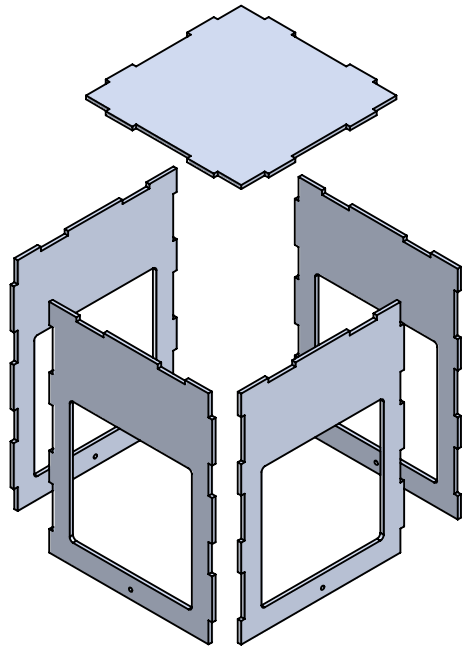
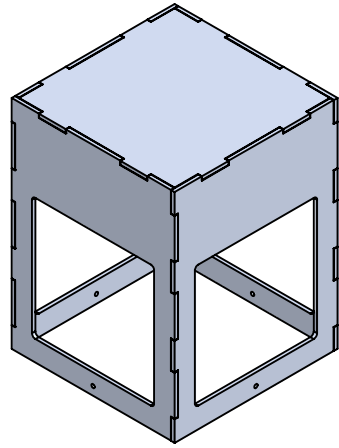

PLATE FLUSH TO POST TUBE TOP



DETAIL B
SCALE 2 : 5





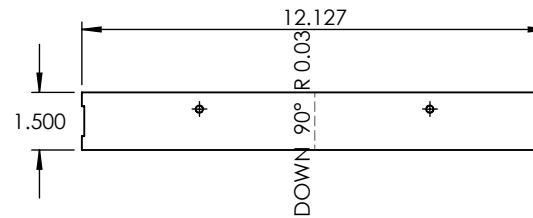
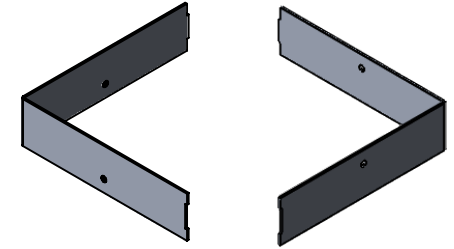
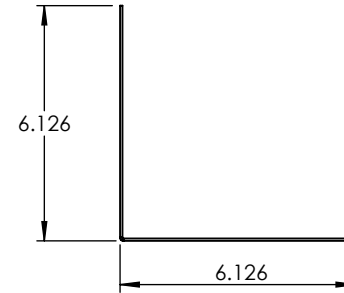
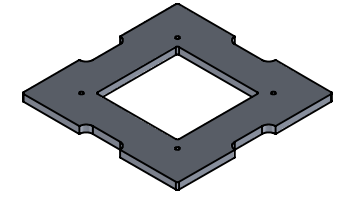
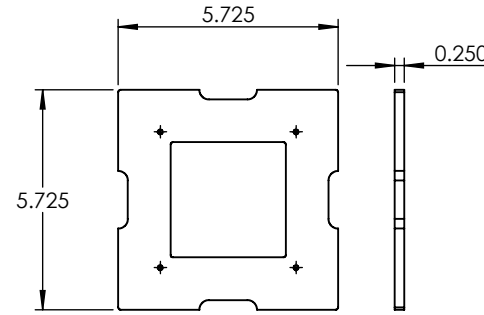
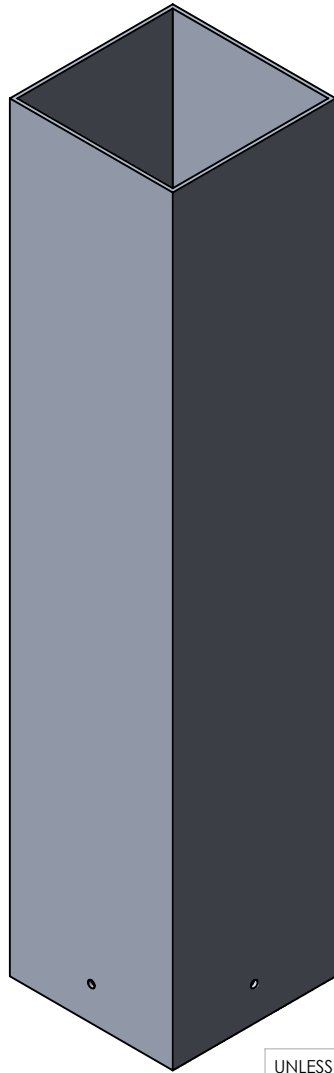
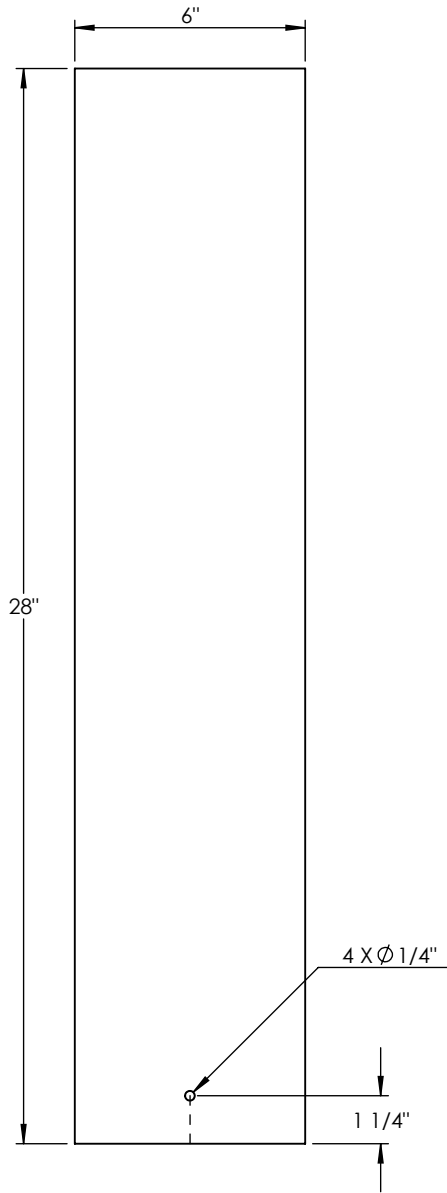

UNLESS OTHERWISE SPECIFIED:

DIMENSIONS ARE IN INCHES
 TOLERANCES:
 FRACTIONAL ±
 ANGULAR: MACH ± BEND ±
 TWO PLACE DECIMAL ±
 THREE PLACE DECIMAL ±

INTERPRET GEOMETRIC
 TOLERANCING PER:

MATERIAL

FINISH

DO NOT SCALE DRAWING

NAME DATE

DRAWN
 CHECKED
 ENG APPR.
 MFG APPR.

Q.A.
 COMMENTS:

6"X6" POST 7.5" LENGTH

TITLE:

BOL-DN-SQFH-36X6-20W-MN-CA-30K

SIZE DWG. NO. REV

A

SCALE: 1:5 WEIGHT: SHEET 6 OF 11

PROPRIETARY AND CONFIDENTIAL
 THE INFORMATION CONTAINED IN THIS
 DRAWING IS THE SOLE PROPERTY OF
 <INSERT COMPANY NAME HERE>. ANY
 REPRODUCTION IN PART OR AS A WHOLE
 WITHOUT THE WRITTEN PERMISSION OF
 <INSERT COMPANY NAME HERE> IS
 PROHIBITED.

NEXT ASSY	USED ON
APPLICATION	

5

4

3

2

1

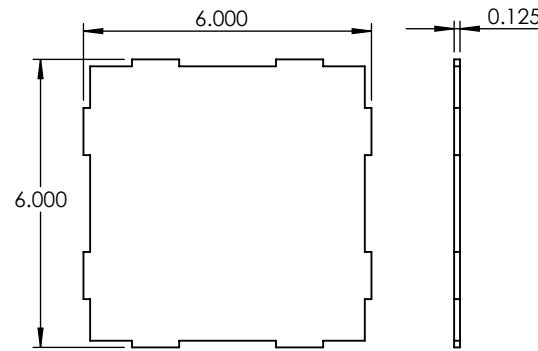
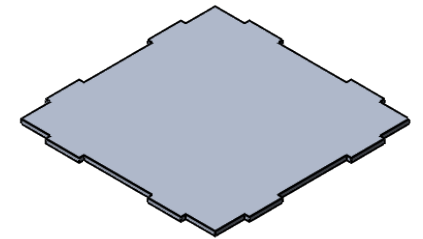
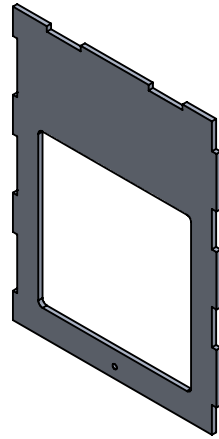
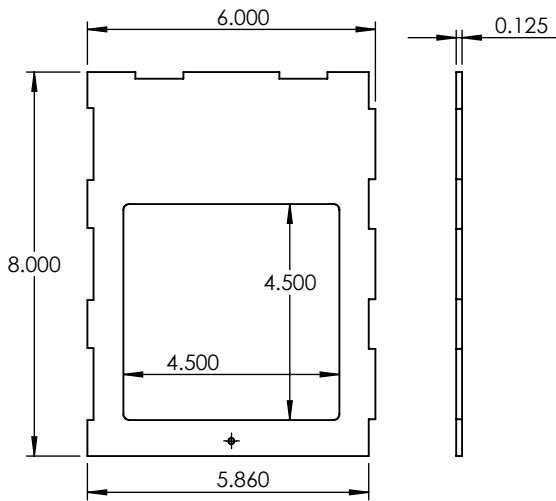

PROPRIETARY AND CONFIDENTIAL
 THE INFORMATION CONTAINED IN THIS DRAWING IS THE SOLE PROPERTY OF <INSERT COMPANY NAME HERE>. ANY REPRODUCTION IN PART OR AS A WHOLE WITHOUT THE WRITTEN PERMISSION OF <INSERT COMPANY NAME HERE> IS PROHIBITED.

		UNLESS OTHERWISE SPECIFIED:	NAME	DATE	ALUMINUM 0.125" PLATE	
		DIMENSIONS ARE IN INCHES TOLERANCES: FRACTIONAL ± ANGULAR: MACH ± BEND ± TWO PLACE DECIMAL ± THREE PLACE DECIMAL ±	DRAWN			
		INTERPRET GEOMETRIC TOLERANCING PER:	CHECKED		SIZE DWG. NO. REV	
		MATERIAL	ENG APPR.			
		FINISH	MFG APPR.			
NEXT ASSY	USED ON		Q.A.			
APPLICATION		DO NOT SCALE DRAWING	COMMENTS:			

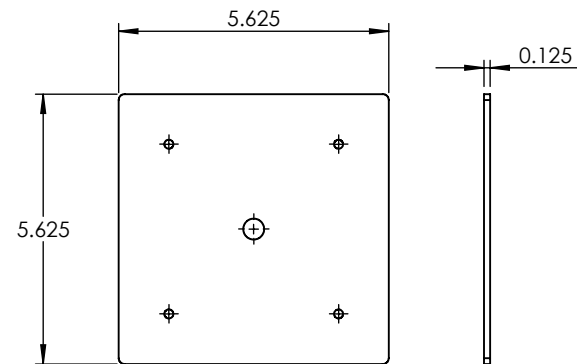
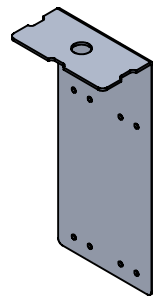
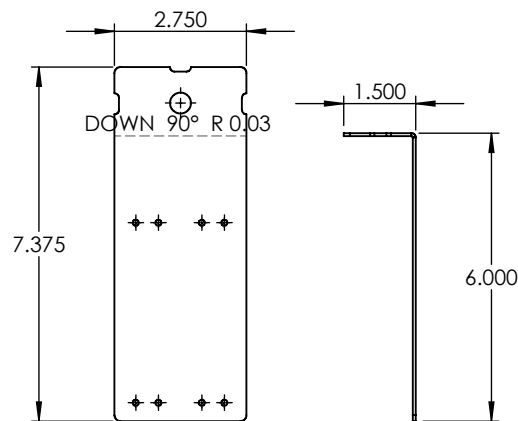
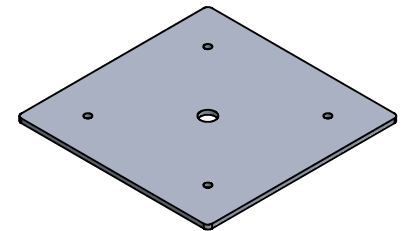
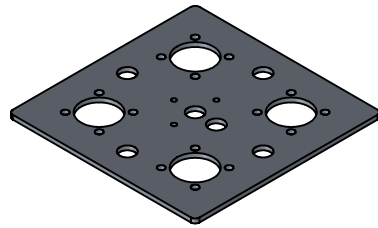
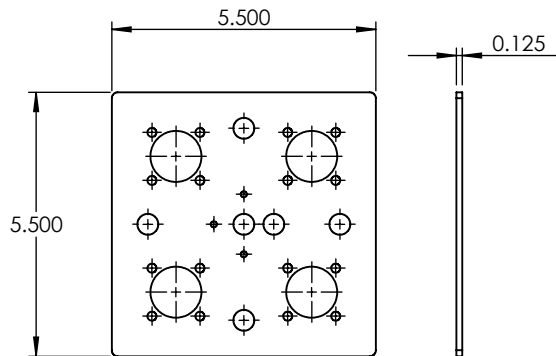

UNLESS OTHERWISE SPECIFIED:		NAME	DATE		
DIMENSIONS ARE IN INCHES		DRAWN		TITLE: BOL-DN-SQFH-36X6-20W-MN-CA-30K	
TOLERANCES:		CHECKED			
FRACTIONAL ±		ENG APPR.			
ANGULAR: MACH ± BEND ±		MFG APPR.			
TWO PLACE DECIMAL ±		Q.A.		SIZE	DWG. NO.
THREE PLACE DECIMAL ±		COMMENTS:		A	
INTERPRET GEOMETRIC TOLERANCING PER:				SCALE: 1:4	WEIGHT:
MATERIAL				SHEET 8 OF 11	
FINISH					
NEXT ASSY	USED ON				
APPLICATION		DO NOT SCALE DRAWING			

PROPRIETARY AND CONFIDENTIAL
 THE INFORMATION CONTAINED IN THIS DRAWING IS THE SOLE PROPERTY OF <INSERT COMPANY NAME HERE>. ANY REPRODUCTION IN PART OR AS A WHOLE WITHOUT THE WRITTEN PERMISSION OF <INSERT COMPANY NAME HERE> IS PROHIBITED.

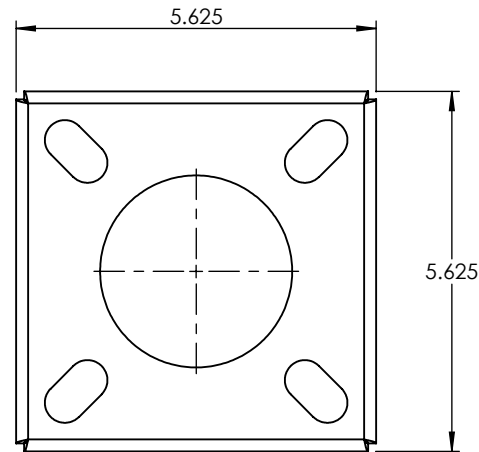
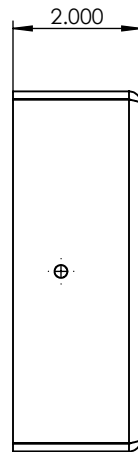
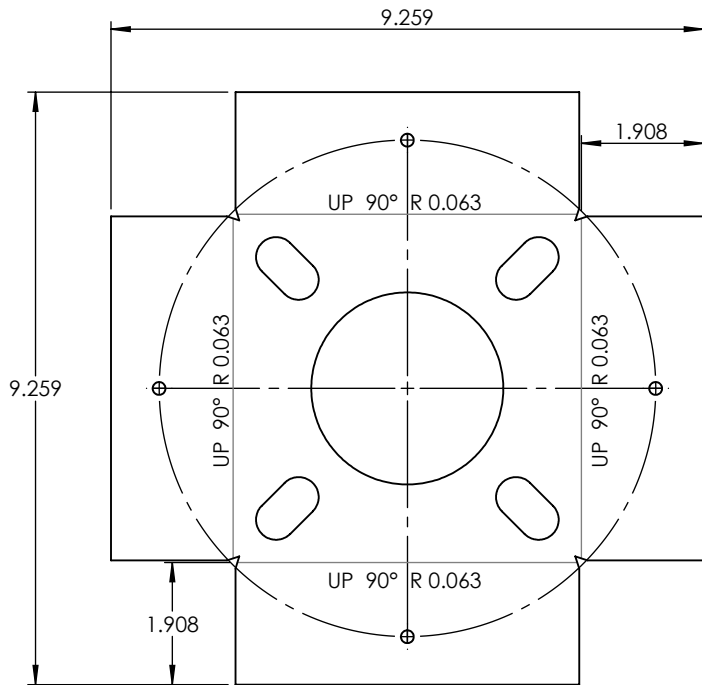
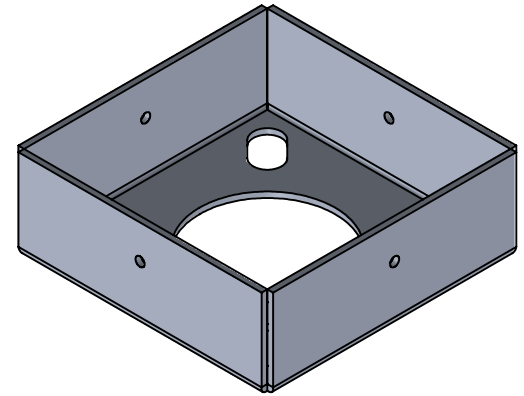

PROPRIETARY AND CONFIDENTIAL
 THE INFORMATION CONTAINED IN THIS DRAWING IS THE SOLE PROPERTY OF <INSERT COMPANY NAME HERE>. ANY REPRODUCTION IN PART OR AS A WHOLE WITHOUT THE WRITTEN PERMISSION OF <INSERT COMPANY NAME HERE> IS PROHIBITED.

		UNLESS OTHERWISE SPECIFIED:	NAME	DATE	ALUMINUM 0.125"	
		DIMENSIONS ARE IN INCHES	DRAWN		TITLE:	
		TOLERANCES:	CHECKED		BOL-DN-SQFH-36X6-20W-MN-CA-30K	
		FRACTIONAL ±	ENG APPR.		SIZE DWG. NO. REV	
		ANGULAR: MACH ± BEND ±	MFG APPR.		A	
		TWO PLACE DECIMAL ±	Q.A.		SCALE: 1:3 WEIGHT: SHEET 9 OF 11	
		THREE PLACE DECIMAL ±	COMMENTS:			
		INTERPRET GEOMETRIC TOLERANCING PER:				
		MATERIAL				
	NEXT ASSY	FINISH				
	USED ON	DO NOT SCALE DRAWING				
	APPLICATION					

5

4

3

2

1

ITEM NO.	PART NUMBER	DESCRIPTION	QTY.
1	BOL-DN-SQFH-36X6-20W-MN-CA-30K-SPUN CONE	SPUN ALUMINUM 0.080"	1

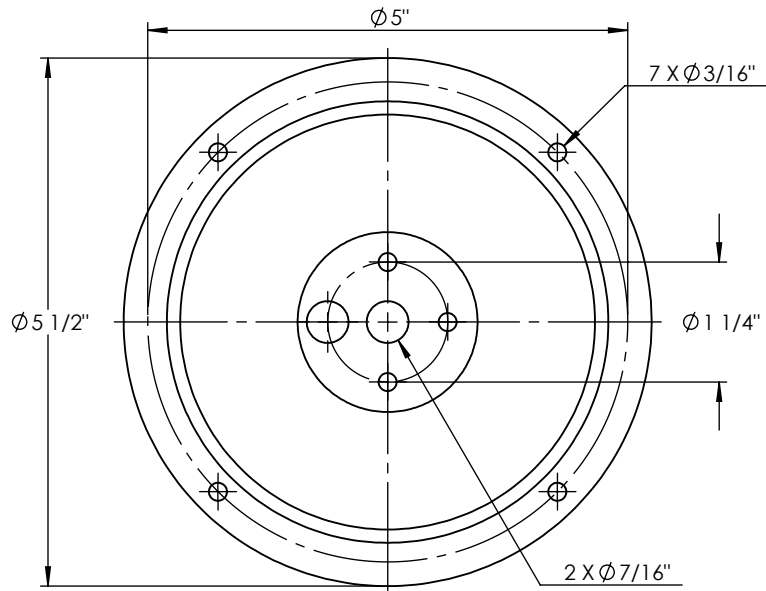
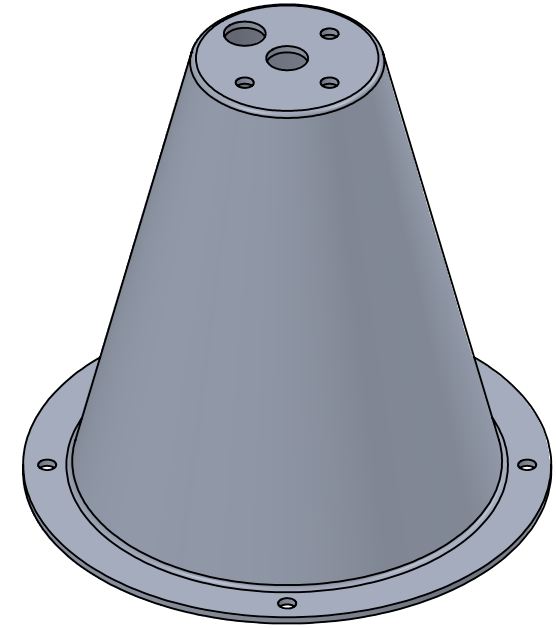
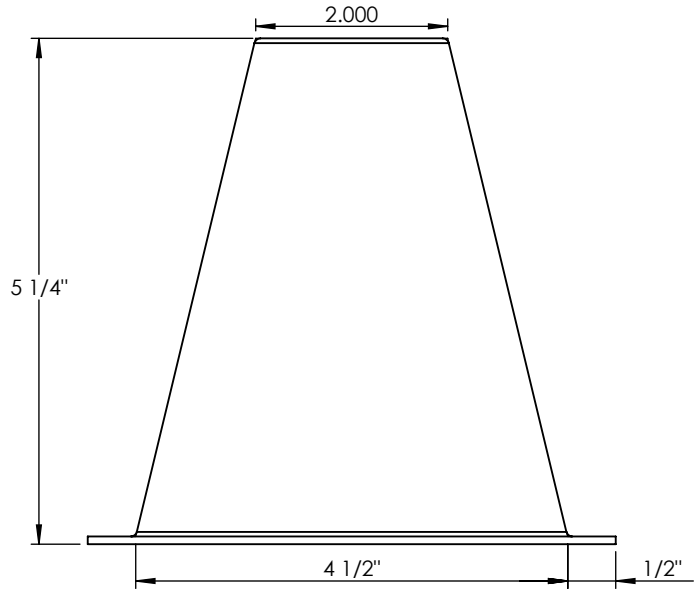

UNLESS OTHERWISE SPECIFIED:		NAME	DATE	SPUN ALUMINUM 0.080"	
DIMENSIONS ARE IN INCHES TOLERANCES: FRACTIONAL ± ANGULAR: MACH ± BEND ± TWO PLACE DECIMAL ± THREE PLACE DECIMAL ±		DRAWN		TITLE:	
		CHECKED		BOL-DN-SQFH-36X6-20W-MN-CA-30K	
		ENG APPR.		SIZE DWG. NO. REV	
		MFG APPR.		SCALE: 1:2 WEIGHT: SHEET 10 OF 11	
INTERPRET GEOMETRIC TOLERANCING PER:		Q.A.			
MATERIAL		COMMENTS:			
FINISH					
NEXT ASSY		USED ON			
APPLICATION		DO NOT SCALE DRAWING			

PROPRIETARY AND CONFIDENTIAL
THE INFORMATION CONTAINED IN THIS DRAWING IS THE SOLE PROPERTY OF <INSERT COMPANY NAME HERE>. ANY REPRODUCTION IN PART OR AS A WHOLE WITHOUT THE WRITTEN PERMISSION OF <INSERT COMPANY NAME HERE> IS PROHIBITED.

