

ALL BEND RADIUS .030"

APPLICATION

DO NOT SCALE DRAWING

UNLESS OTHERWISE SPECIFIED:

DIMENSIONS ARE IN INCHES  
 TOLERANCES:  
 FRACTIONAL ± .003  
 ANGULAR: MACH ± .01 BEND ±  
 TWO PLACE DECIMAL ±  
 THREE PLACE DECIMAL ±.001

INTERPRET GEOMETRIC  
 TOLERANCING PER:

MATERIAL

FINISH

NAME

DATE

DRAWN

CHECKED

ENG APPR.

MFG APPR.

Q.A.

COMMENTS:

FIXTURE HEAD

TITLE:

TUS1340L-ORB-WF-EMR-PE-27K

SIZE DWG. NO.

REV

**A** TICKET 27089

SCALE: 1:8

WEIGHT:

SHEET 1 OF 14

5

4

3

2

1

ITEM NO.	PART NUMBER	DESCRIPTION	QTY.	CUT
1	TUS1340L-ORB-WF-EMR-PE-27K-TOP SPUN BOWL	SPUN ALUMINUM 0.080"	1	
2	TUS1340L-ORB-WF-EMR-PE-27K-TOP ROLLED CIRCLE	22 GAUGE	1	
3	TUS1340L-ORB-WF-EMR-PE-27K-TOP SQUARE	22 GAUGE	1	
4	TUS1340L-ORB-WF-EMR-PE-27K-BACKPLATE	22 GAUGE	1	
5	TUS1340L-ORB-WF-EMR-PE-27K-BACKPLATE TAB	22 GAUGE	2	
6	TUS1340L-ORB-WF-EMR-PE-27K-LED SPACER	22 GAUGE	1	
7	TUS1340L-ORB-WF-EMR-PE-27K-FIREPLATE	22 GAUGE	1	
8	TUS1340L-ORB-WF-EMR-PE-27K-FRONT FRAME SENSOR	22 GAUGE	1	
9	TUS1340L-ORB-WF-EMR-PE-27K-FRAME TOP SIDE	22 GAUGE	2	
10	TUS1340L-ORB-WF-EMR-PE-27K-FRAME TOP WEDGE	22 GAUGE	1	
11	TUS1340L-ORB-WF-EMR-PE-27K-FRAME TOP WEDGE SIDE	22 GAUGE	2	
12	TUS1340L-ORB-WF-EMR-PE-27K-FRAME TABS	22 GAUGE	2	
13	TUS1340L-ORB-WF-EMR-PE-27K-FRAME BACK TABS	22 GAUGE	2	
14	TUS1340L-ORB-WF-EMR-PE-27K-FRAME BOTTOM BEND	22 GAUGE	1	
15	TUS1340L-ORB-WF-EMR-PE-27K-FRAME BOTTOM BEND SIDE	22 GAUGE	2	
16	TUS1340L-ORB-WF-EMR-PE-27K-BOTTOM CAP	22 GAUGE	1	
17	TUS1340L-ORB-WF-EMR-PE-27K-ACRYLIC	ACRYLIC	2	
18	ACE-G10-55-190-EMR PACK	DRIVER-BATTERY	1	
19	EMR BUTTON	BUTTON	1	
20	PHOTO CELL MODEL 2.0	SENSOR	1	
21	ESPEL VEL29070MVH-1	DRIVER	2	
22	AItailed PN110B RevC	LED	4	

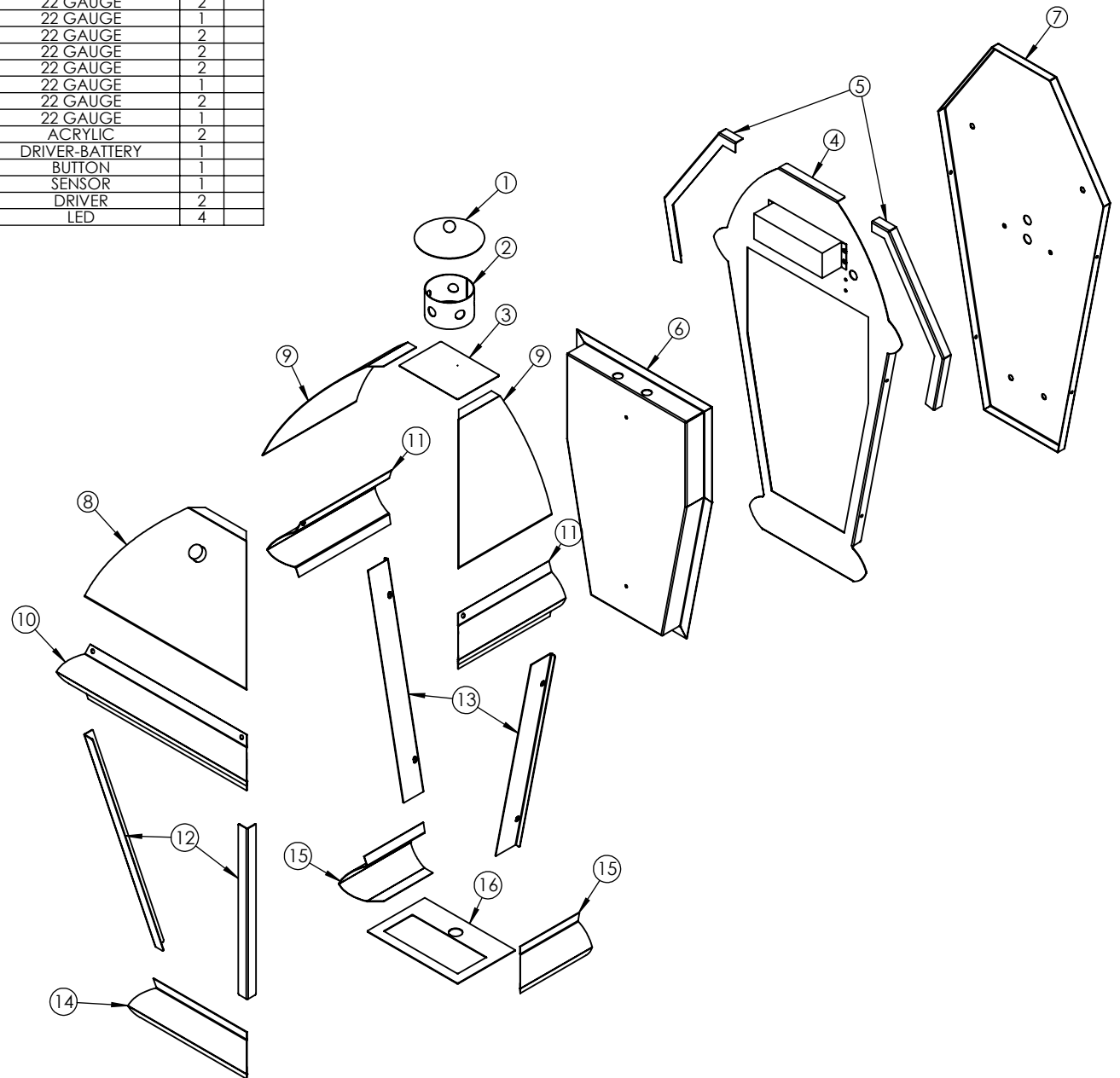

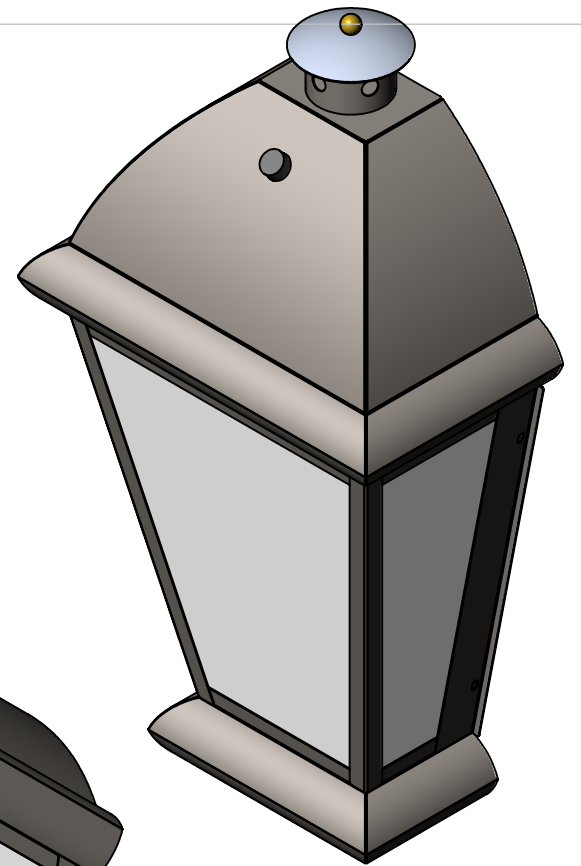
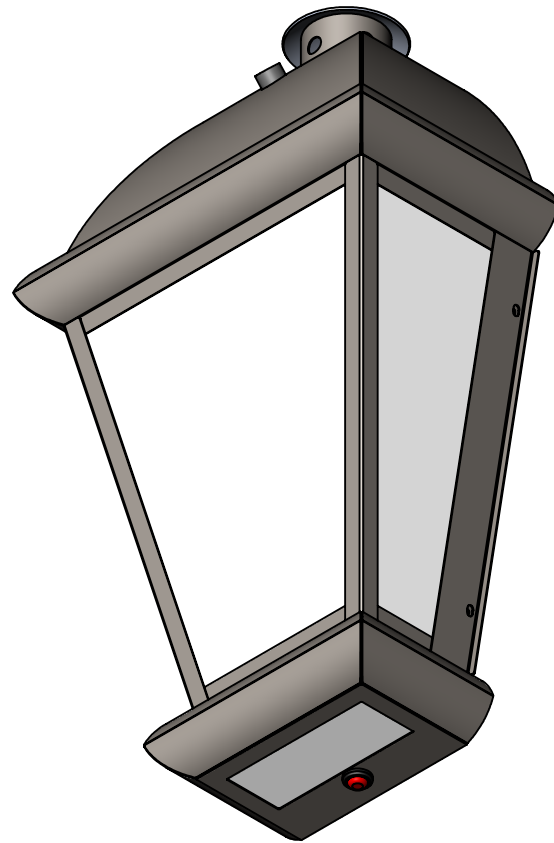
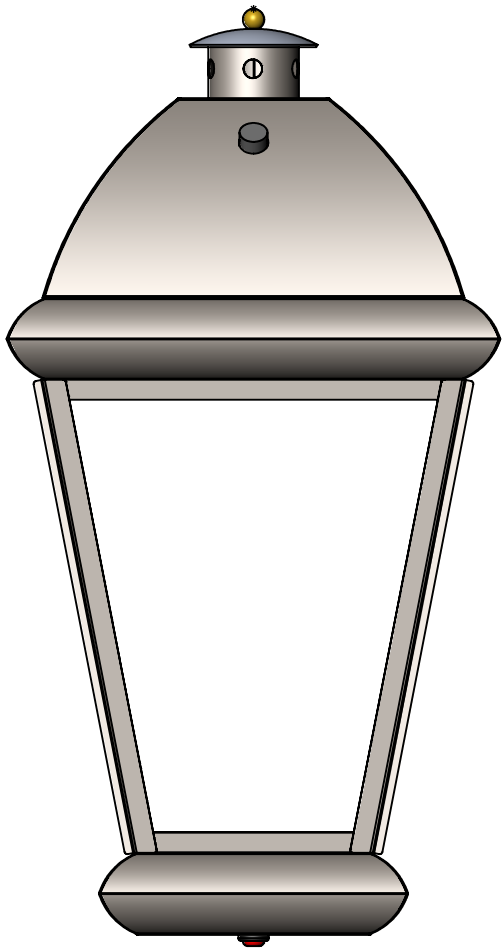
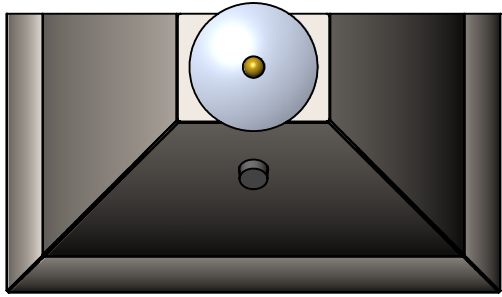

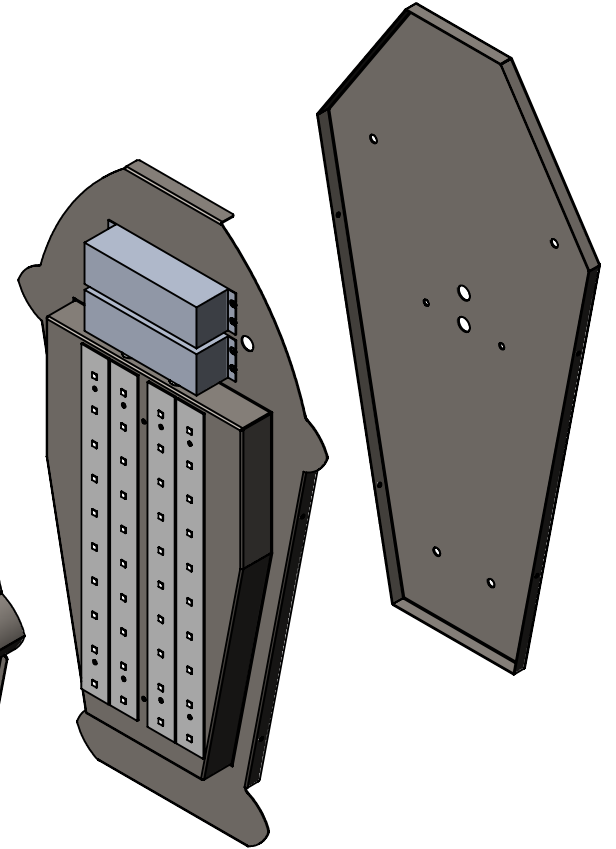
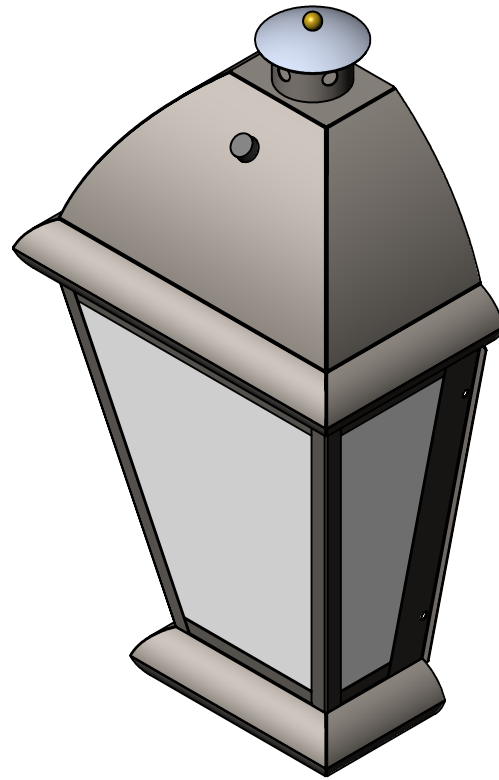
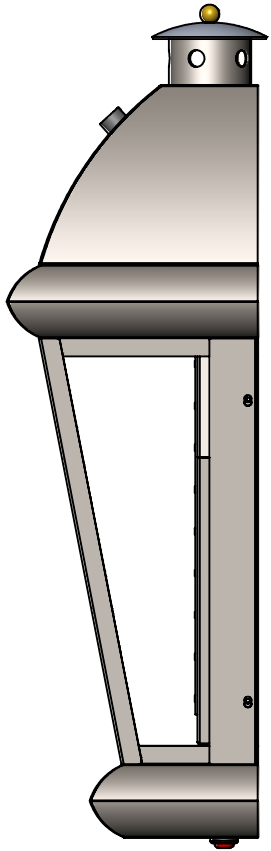

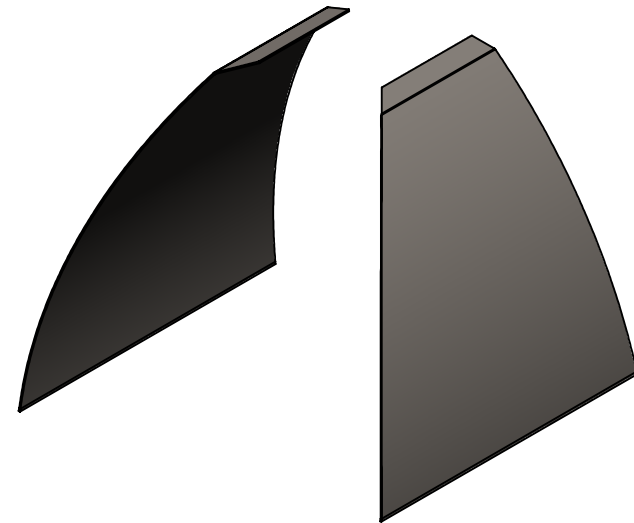
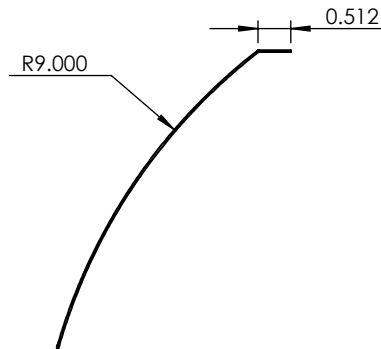
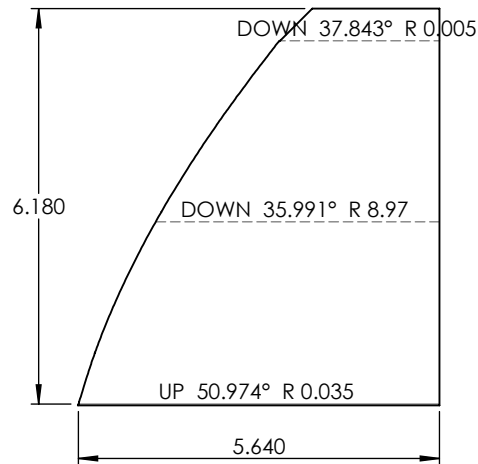
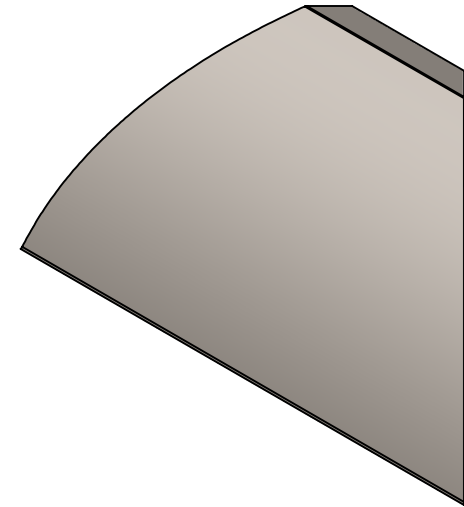
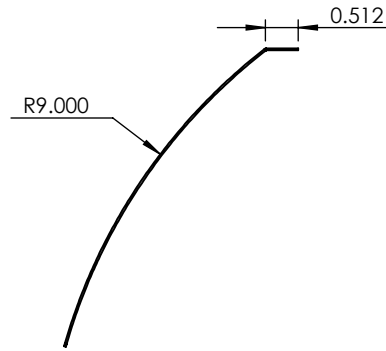
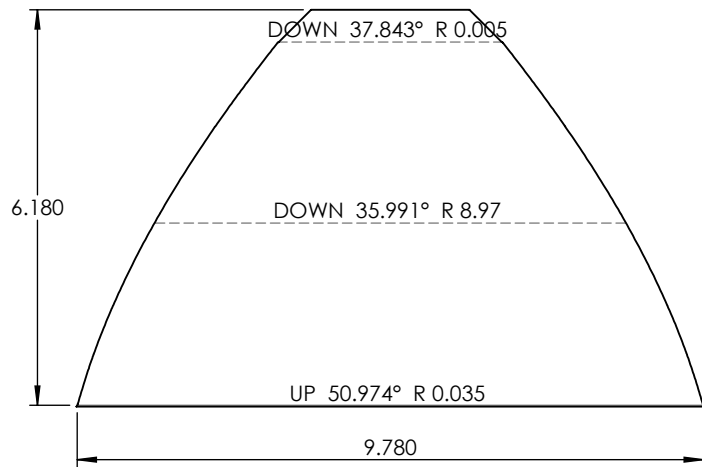

**PROPRIETARY AND CONFIDENTIAL**  
 THE INFORMATION CONTAINED IN THIS DRAWING IS THE SOLE PROPERTY OF <INSERT COMPANY NAME HERE>. ANY REPRODUCTION IN PART OR AS A WHOLE WITHOUT THE WRITTEN PERMISSION OF <INSERT COMPANY NAME HERE> IS PROHIBITED.

		UNLESS OTHERWISE SPECIFIED:		NAME	DATE
		DIMENSIONS ARE IN INCHES		DRAWN	
		TOLERANCES:		CHECKED	
		FRACTIONAL ±		ENG APPR.	
		ANGULAR: MACH ± BEND ±		MFG APPR.	
		TWO PLACE DECIMAL ±		Q.A.	
		THREE PLACE DECIMAL ±		COMMENTS:	
		INTERPRET GEOMETRIC TOLERANCING PER:			
		MATERIAL			
	NEXT ASSY	USED ON			
		FINISH			
	APPLICATION	DO NOT SCALE DRAWING			

<b>22 GAUGE</b>		
TITLE:		
TUS1340L-ORB-WF-EMR-PE-27K		
SIZE	DWG. NO.	REV
<b>A</b>		
SCALE: 1:3	WEIGHT:	SHEET 5 OF 14

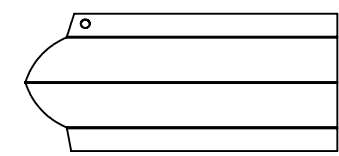
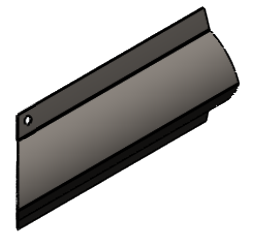
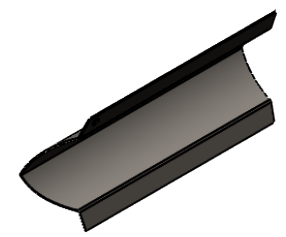
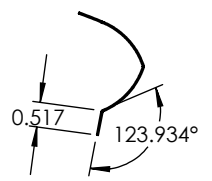
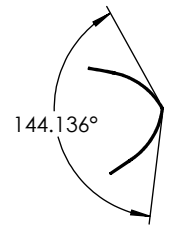
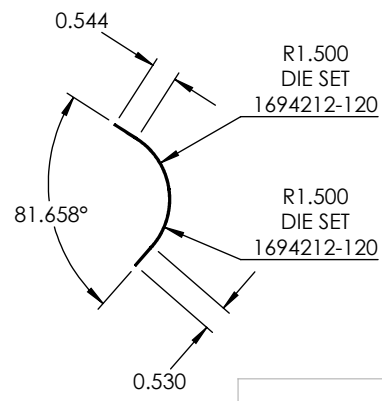
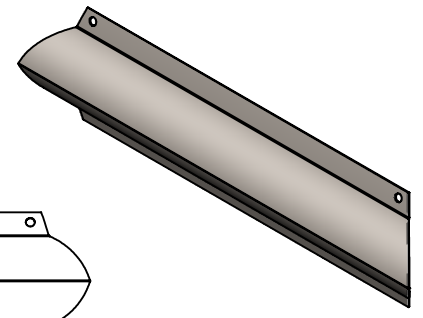
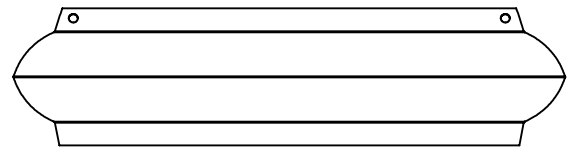
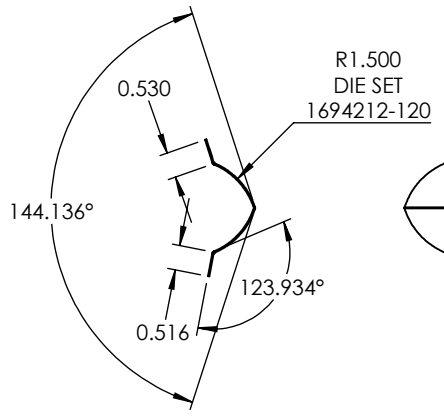
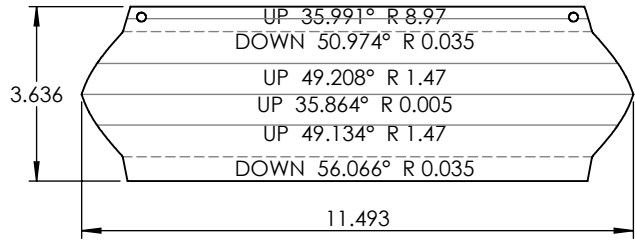

**PROPRIETARY AND CONFIDENTIAL**  
 THE INFORMATION CONTAINED IN THIS DRAWING IS THE SOLE PROPERTY OF <INSERT COMPANY NAME HERE>. ANY REPRODUCTION IN PART OR AS A WHOLE WITHOUT THE WRITTEN PERMISSION OF <INSERT COMPANY NAME HERE> IS PROHIBITED.

		UNLESS OTHERWISE SPECIFIED:	NAME	DATE
		DIMENSIONS ARE IN INCHES TOLERANCES: FRACTIONAL ± ANGULAR: MACH ± BEND ± TWO PLACE DECIMAL ± THREE PLACE DECIMAL ±	DRAWN	
		INTERPRET GEOMETRIC TOLERANCING PER:	CHECKED	
		MATERIAL	ENG APPR.	
		FINISH	MFG APPR.	
NEXT ASSY	USED ON		Q.A.	
		APPLICATION	COMMENTS:	
		DO NOT SCALE DRAWING		

22 GAUGE		
TITLE: TUS1340L-ORB-WF-EMR-PE-27K		
SIZE <b>A</b>	DWG. NO.	REV
SCALE: 1:4	WEIGHT:	SHEET 6 OF 14

5

4

3

2

1

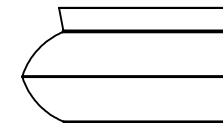
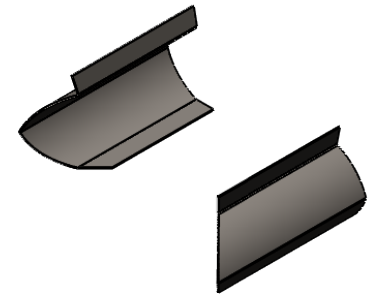
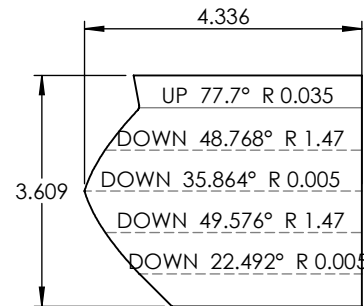
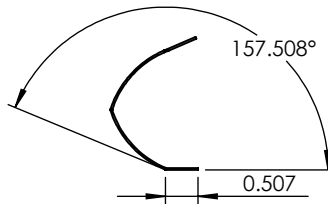
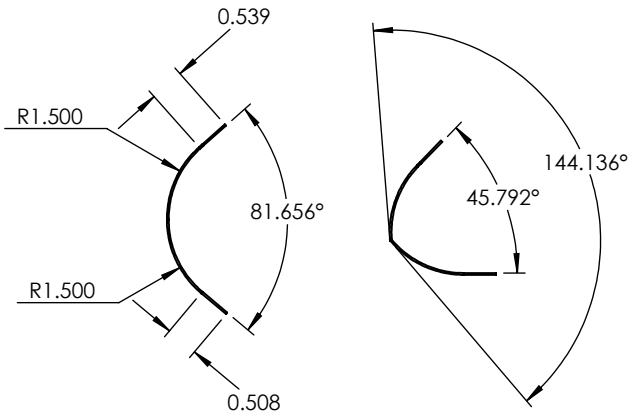
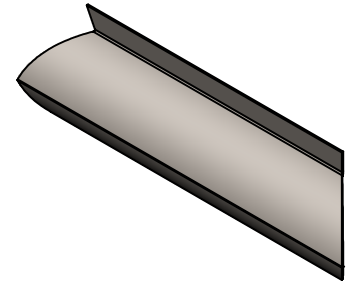
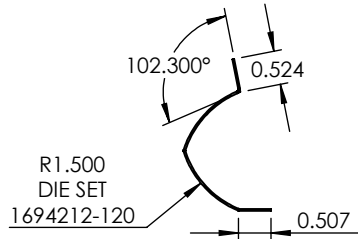
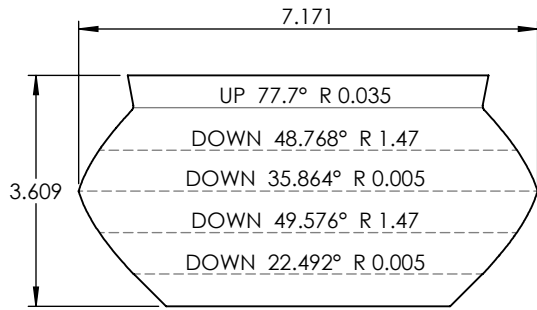

**PROPRIETARY AND CONFIDENTIAL**  
 THE INFORMATION CONTAINED IN THIS DRAWING IS THE SOLE PROPERTY OF <INSERT COMPANY NAME HERE>. ANY REPRODUCTION IN PART OR AS A WHOLE WITHOUT THE WRITTEN PERMISSION OF <INSERT COMPANY NAME HERE> IS PROHIBITED.

		UNLESS OTHERWISE SPECIFIED:		NAME	DATE
		DIMENSIONS ARE IN INCHES TOLERANCES: FRACTIONAL ± ANGULAR: MACH ± BEND ± TWO PLACE DECIMAL ± THREE PLACE DECIMAL ±	DRAWN		
		INTERPRET GEOMETRIC TOLERANCING PER:	CHECKED		
		MATERIAL	ENG APPR.		
		FINISH	MFG APPR.		
NEXT ASSY	USED ON		Q.A.		
			COMMENTS:		
APPLICATION		DO NOT SCALE DRAWING			

22 GAUGE

TITLE:

TUS1340L-ORB-WF-EMR-PE-27K

SIZE	DWG. NO.	REV
<b>A</b>		
SCALE: 1:3	WEIGHT:	SHEET 7 OF 14

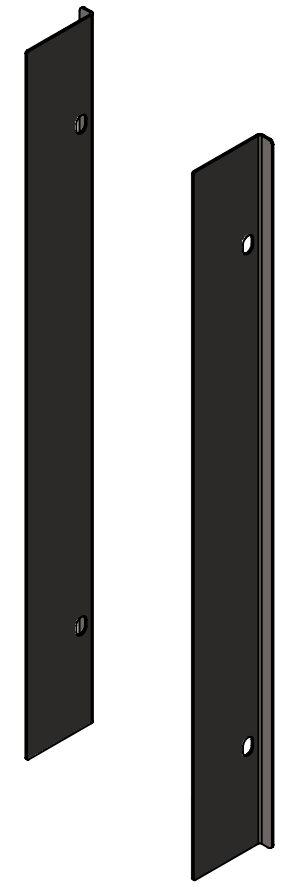
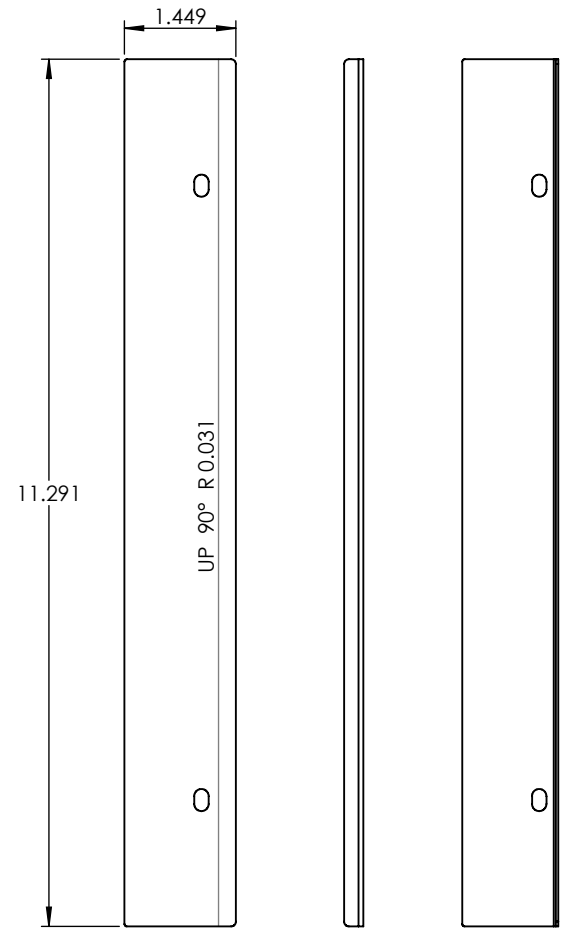
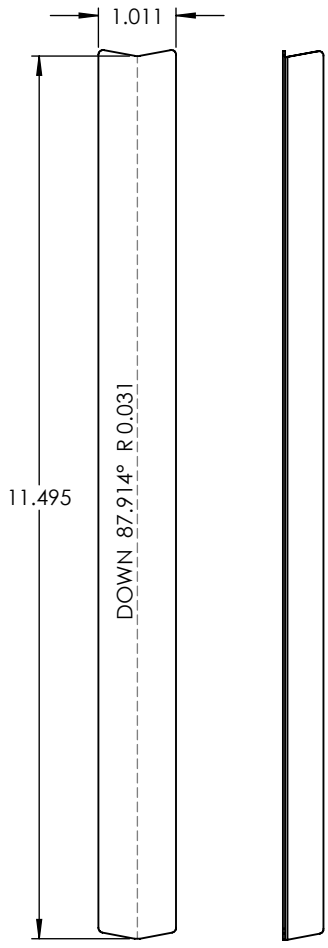
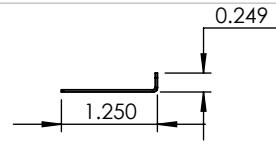
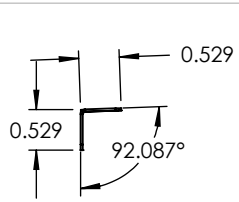

**PROPRIETARY AND CONFIDENTIAL**  
 THE INFORMATION CONTAINED IN THIS DRAWING IS THE SOLE PROPERTY OF <INSERT COMPANY NAME HERE>. ANY REPRODUCTION IN PART OR AS A WHOLE WITHOUT THE WRITTEN PERMISSION OF <INSERT COMPANY NAME HERE> IS PROHIBITED.

		UNLESS OTHERWISE SPECIFIED:		NAME	DATE
		DIMENSIONS ARE IN INCHES	DRAWN		
		TOLERANCES:	CHECKED		
		FRACTIONAL ±	ENG APPR.		
		ANGULAR: MACH ± BEND ±	MFG APPR.		
		TWO PLACE DECIMAL ±	Q.A.		
		THREE PLACE DECIMAL ±	COMMENTS:		
		INTERPRET GEOMETRIC TOLERANCING PER:			
		MATERIAL			
NEXT ASSY	USED ON	FINISH			
APPLICATION		DO NOT SCALE DRAWING			

22 GAUGE		
TITLE:		
TUS1340L-ORB-WF-EMR-PE-27K		
SIZE	DWG. NO.	REV
<b>A</b>		
SCALE: 1:2.5WEIGHT:		SHEET 8 OF 14

5

4

3

2

1





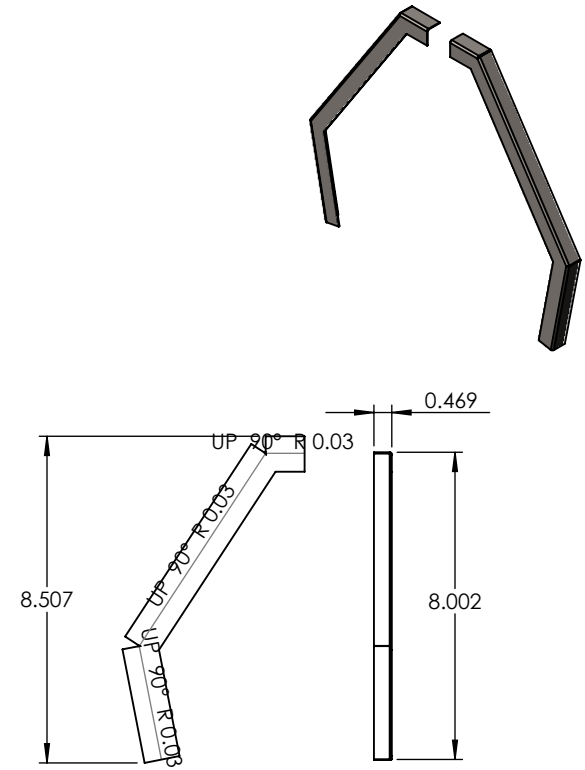
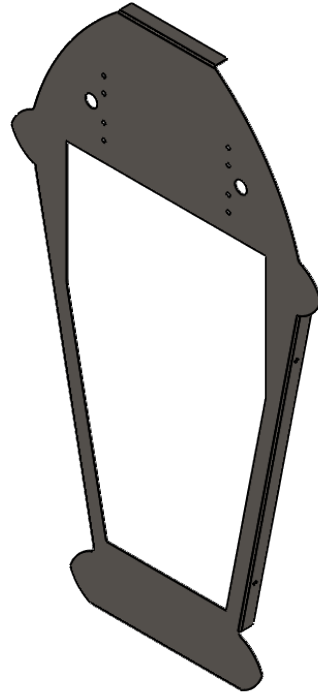
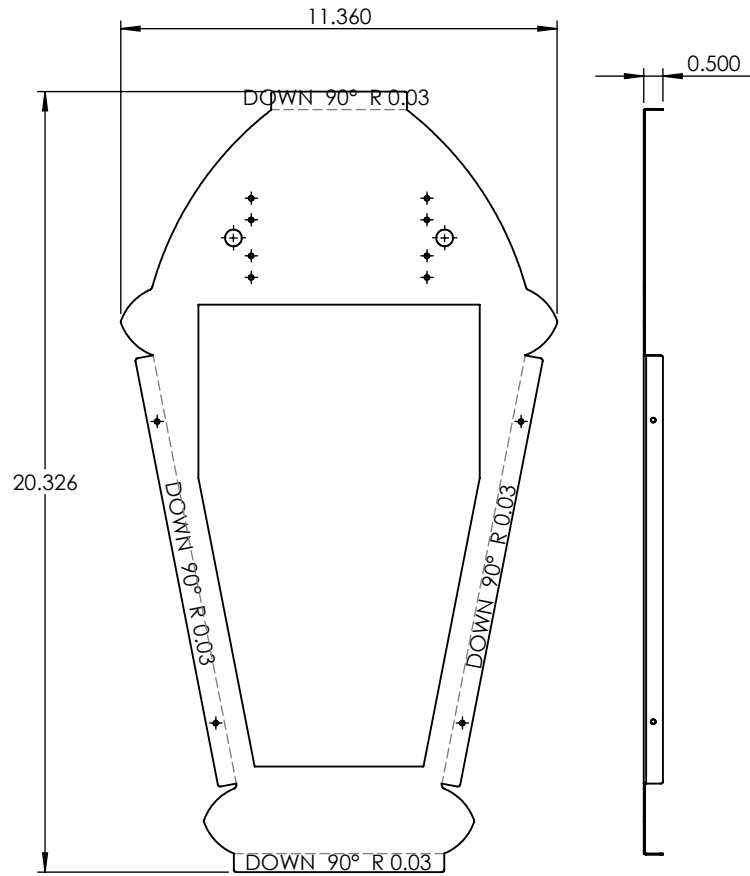

UNLESS OTHERWISE SPECIFIED:		NAME	DATE	22 GAUGE	
DIMENSIONS ARE IN INCHES		DRAWN			
TOLERANCES:		CHECKED		TITLE: TUS1340L-ORB-WF-EMR-PE-27K	
FRACTIONAL ±		ENG APPR.			
ANGULAR: MACH ± BEND ±		MFG APPR.			
TWO PLACE DECIMAL ±		Q.A.		SIZE DWG. NO. REV	
THREE PLACE DECIMAL ±		COMMENTS:		SCALE: 1:5 WEIGHT: SHEET 10 OF 14	
INTERPRET GEOMETRIC TOLERANCING PER:					
MATERIAL					
FINISH					
NEXT ASSY		USED ON			
APPLICATION		DO NOT SCALE DRAWING			

**PROPRIETARY AND CONFIDENTIAL**  
 THE INFORMATION CONTAINED IN THIS DRAWING IS THE SOLE PROPERTY OF <INSERT COMPANY NAME HERE>. ANY REPRODUCTION IN PART OR AS A WHOLE WITHOUT THE WRITTEN PERMISSION OF <INSERT COMPANY NAME HERE> IS PROHIBITED.

5

4

3

2

1

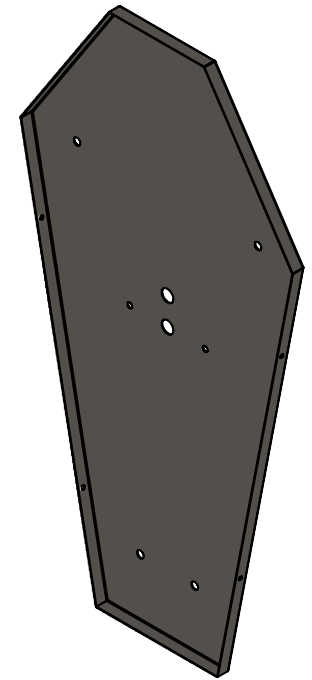
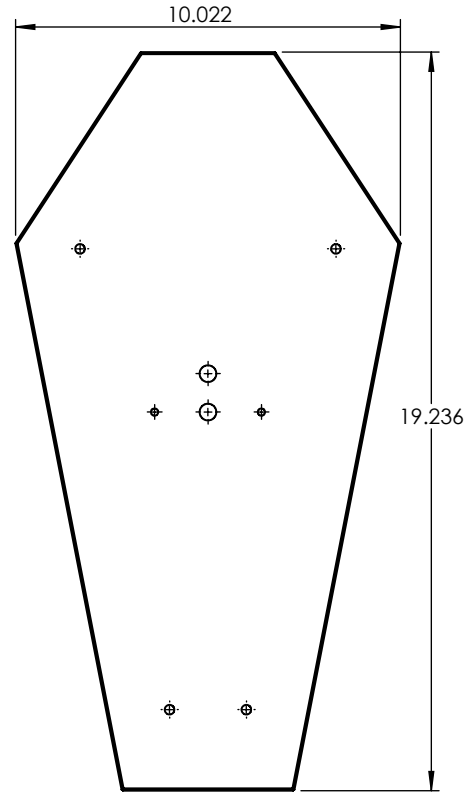
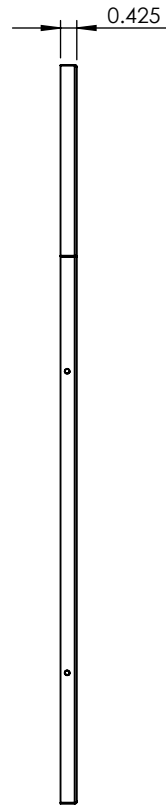
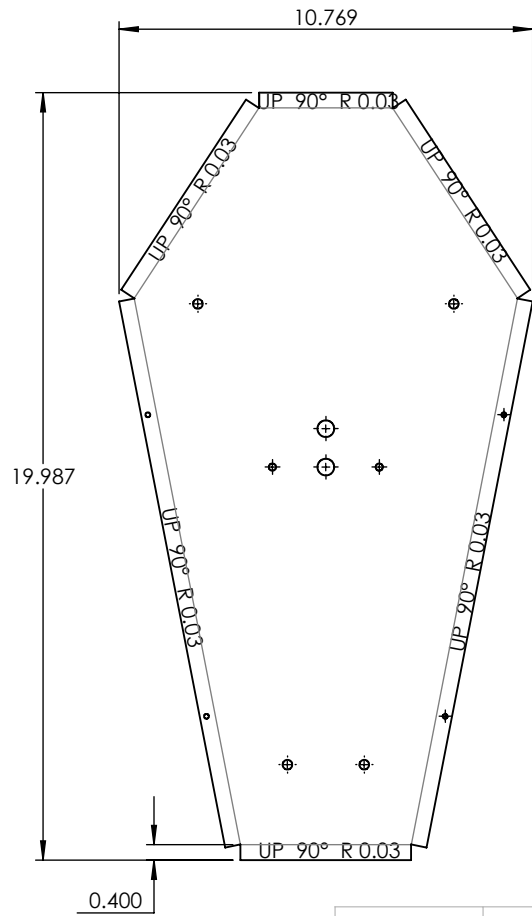

**PROPRIETARY AND CONFIDENTIAL**  
 THE INFORMATION CONTAINED IN THIS DRAWING IS THE SOLE PROPERTY OF <INSERT COMPANY NAME HERE>. ANY REPRODUCTION IN PART OR AS A WHOLE WITHOUT THE WRITTEN PERMISSION OF <INSERT COMPANY NAME HERE> IS PROHIBITED.

		UNLESS OTHERWISE SPECIFIED:		NAME	DATE
		DIMENSIONS ARE IN INCHES	DRAWN		
		TOLERANCES:	CHECKED		
		FRACTIONAL ±	ENG APPR.		
		ANGULAR: MACH ± BEND ±	MFG APPR.		
		TWO PLACE DECIMAL ±	Q.A.		
		THREE PLACE DECIMAL ±	COMMENTS:		
		INTERPRET GEOMETRIC TOLERANCING PER:			
		MATERIAL			
		FINISH			
NEXT ASSY	USED ON				
APPLICATION	DO NOT SCALE DRAWING				

22 GAUGE

TITLE:

TUS1340L-ORB-WF-EMR-PE-27K

SIZE	DWG. NO.	REV
<b>A</b>		

SCALE: 1:5 WEIGHT: SHEET 11 OF 14

ITEM NO.	PART NUMBER	DESCRIPTION	QTY.
1	TUS1340L-ORB-WF-EMR-PE-27K-TOP SPUN CAP	SPUN ALUMINUM 0.080"	1

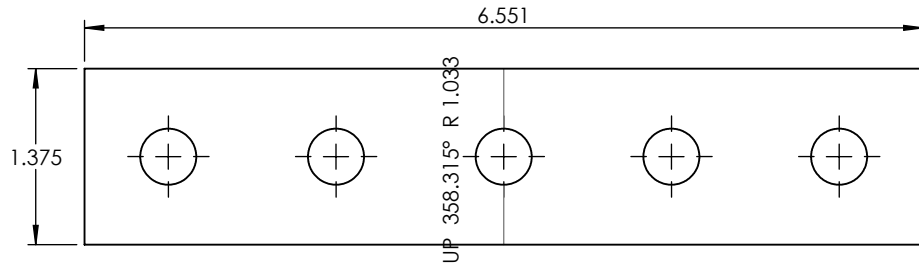
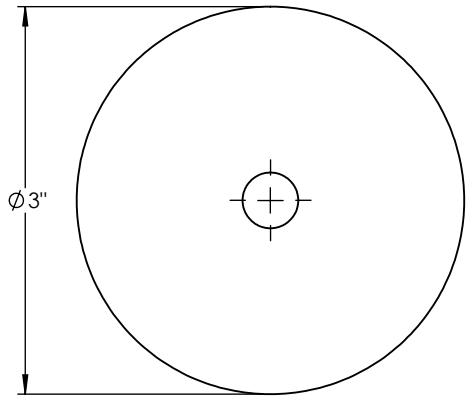
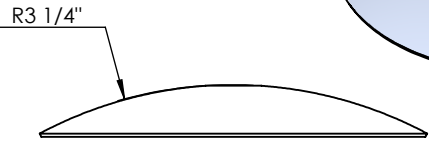
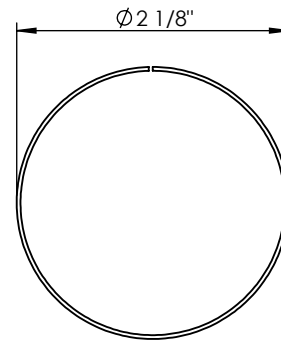
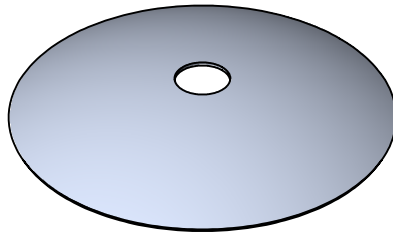
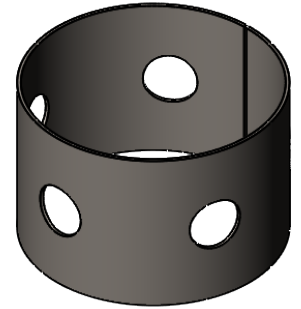
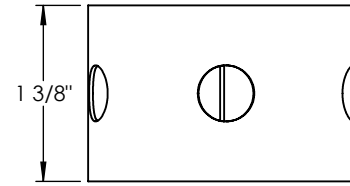
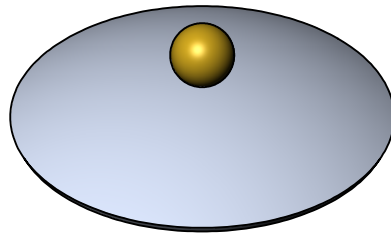

**PROPRIETARY AND CONFIDENTIAL**  
 THE INFORMATION CONTAINED IN THIS DRAWING IS THE SOLE PROPERTY OF <INSERT COMPANY NAME HERE>. ANY REPRODUCTION IN PART OR AS A WHOLE WITHOUT THE WRITTEN PERMISSION OF <INSERT COMPANY NAME HERE> IS PROHIBITED.

UNLESS OTHERWISE SPECIFIED:		NAME	DATE
DIMENSIONS ARE IN INCHES		DRAWN	
TOLERANCES:		CHECKED	
FRACTIONAL ±		ENG APPR.	
ANGULAR: MACH ± BEND ±		MFG APPR.	
TWO PLACE DECIMAL ±		Q.A.	
THREE PLACE DECIMAL ±		COMMENTS:	
INTERPRET GEOMETRIC TOLERANCING PER:			
MATERIAL			
NEXT ASSY	USED ON		
FINISH			
APPLICATION			
DO NOT SCALE DRAWING			

SPUN ALUMINUM 0.080"		
TITLE:		
TUS1340L-ORB-WF-EMR-PE-27K		
SIZE	DWG. NO.	REV
<b>A</b>		
SCALE: 1:1.5WEIGHT:		SHEET 12 OF 14

