

ITEM NO.	PART NUMBER	DESCRIPTION	QTY.	CUT
1	POOL-HDBOL14-8W-MN-WP1-40K-ANCHOR PLATE	ALUMINUM 0.125" PLATE	1	
2	POOL-HDBOL14-8W-MN-WP1-40K-FRONT PLATE	ALUMINUM 0.125" PLATE	1	
3	POOL-HDBOL14-8W-MN-WP1-40K-SIDES PLATE	ALUMINUM 0.125" PLATE	2	
4	POOL-HDBOL14-8W-MN-WP1-40K-TOP PLATE	ALUMINUM 0.125" PLATE	1	
5	POOL-HDBOL14-8W-MN-WP1-40K-FRONT PLATE	ALUMINUM 0.125" PLATE	1	
6	POOL-HDBOL14-8W-MN-WP1-40K-FRONT PLATE BRACKET	ALUMINUM 0.0635"	1	
7	POOL-HDBOL14-8W-MN-WP1-40K-ACRYLIC	ACRYLIC	1	
8	POOL-HDBOL14-8W-MN-WP1-40K-BRACKET	ALUMINUM 0.0635"	1	
9	POOL-HDBOL14-8W-MN-WP1-40K-LED PLATE	ALUMINUM 0.0635"	1	
10	DS-15W-350C1542010-3001	DRIVER	1	
11	Alftailed_PN1004RevD	LED	1	

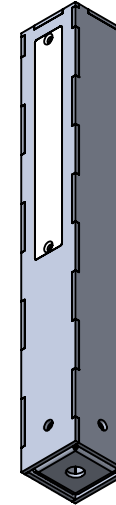

UNLESS OTHERWISE SPECIFIED:		NAME	DATE	TITLE:	
DIMENSIONS ARE IN INCHES		DRAWN		POOL-HDBOL14-8W-MN-WP1-40K	
TOLERANCES:		CHECKED			
FRACTIONAL ± .003		ENG APPR.			
ANGULAR: MACH ± .01 BEND ±		MFG APPR.			
TWO PLACE DECIMAL ±		Q.A.		SIZE	DWG. NO.
THREE PLACE DECIMAL ±.001		COMMENTS:		A	TICKET 27127
INTERPRET GEOMETRIC TOLERANCING PER:				SCALE: 1:5	WEIGHT:
MATERIAL					SHEET 1 OF 6
FINISH					

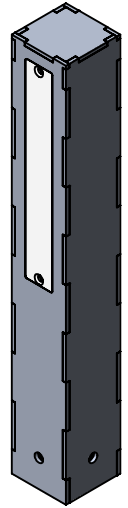
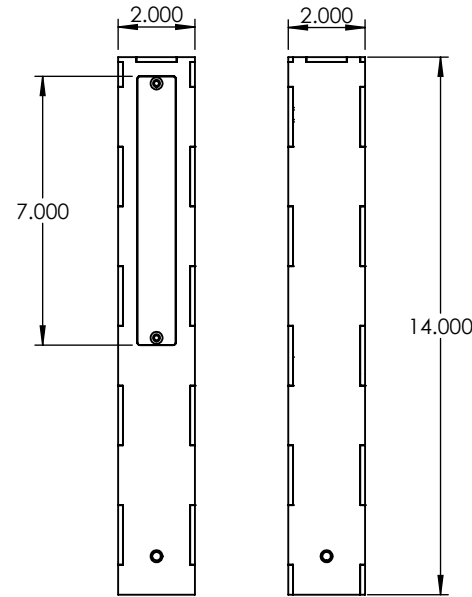
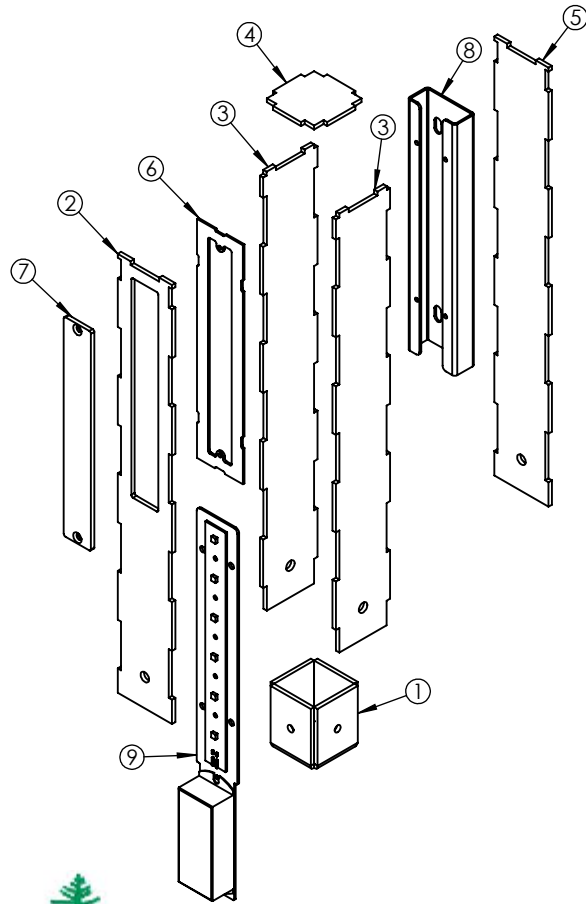

ALL BEND RADIUS .030"

APPLICATION

DO NOT SCALE DRAWING

5

4

3

2

1

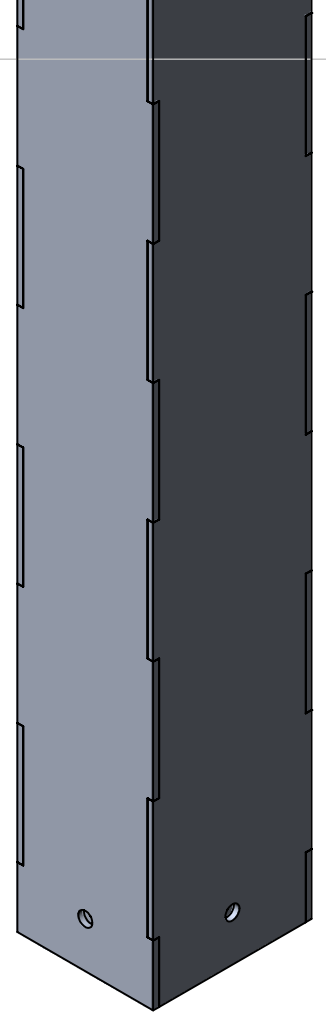
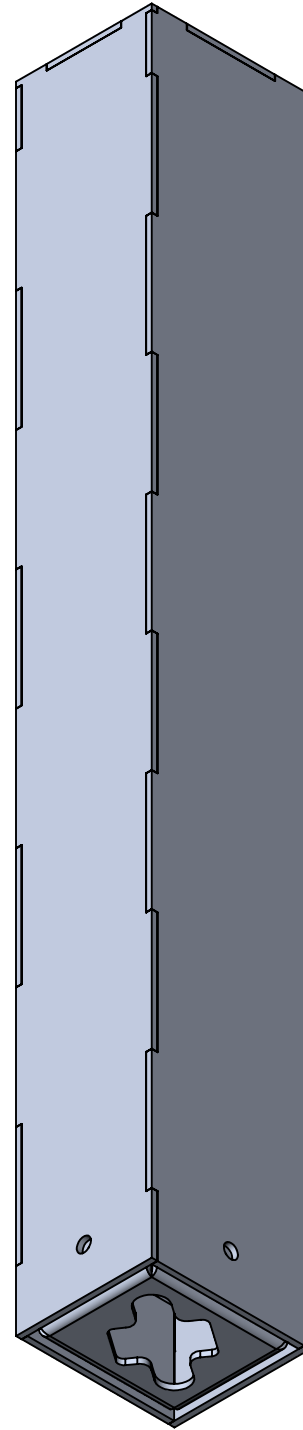
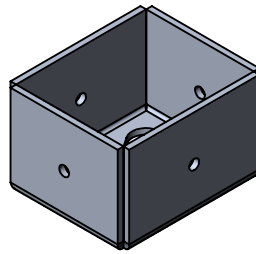
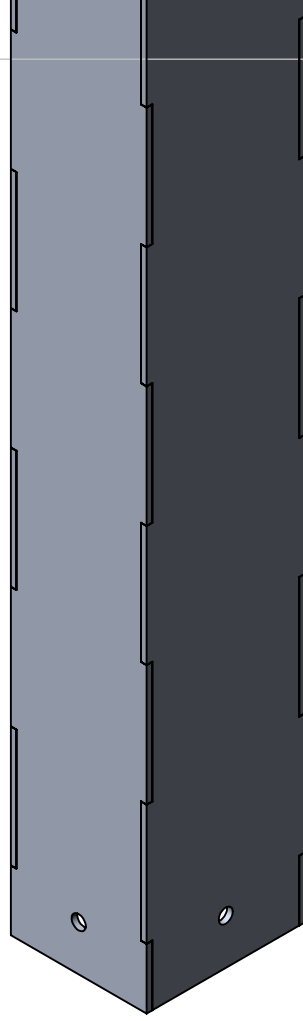
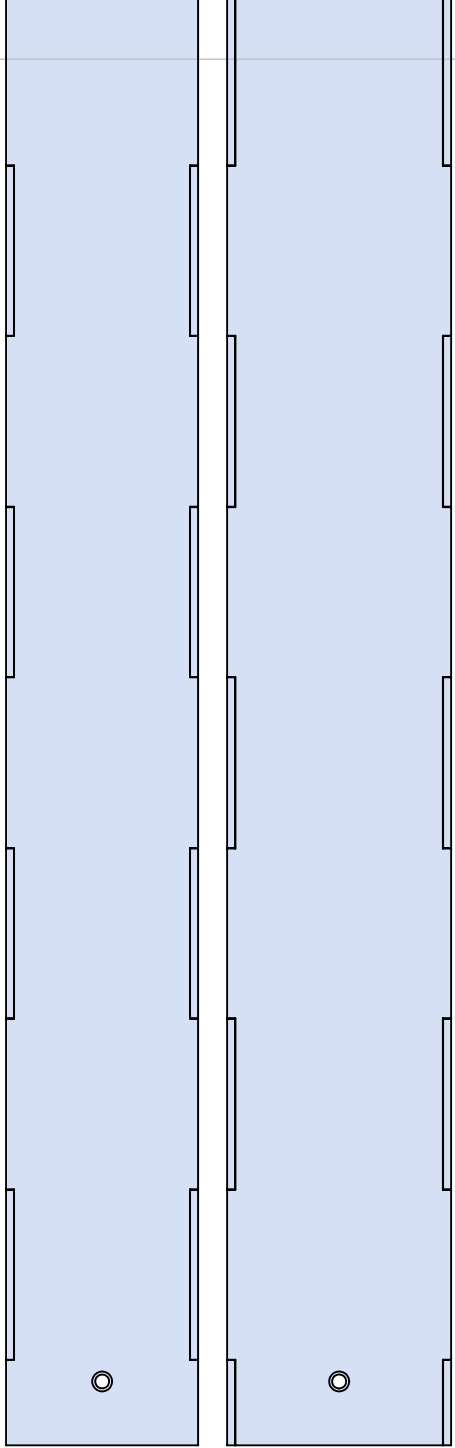

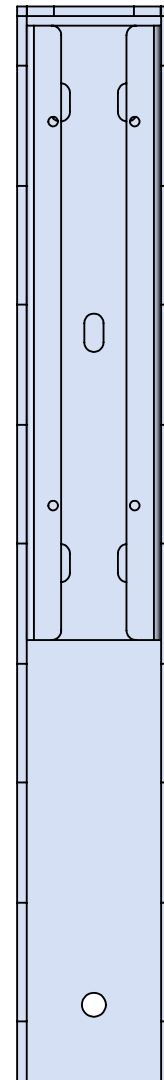
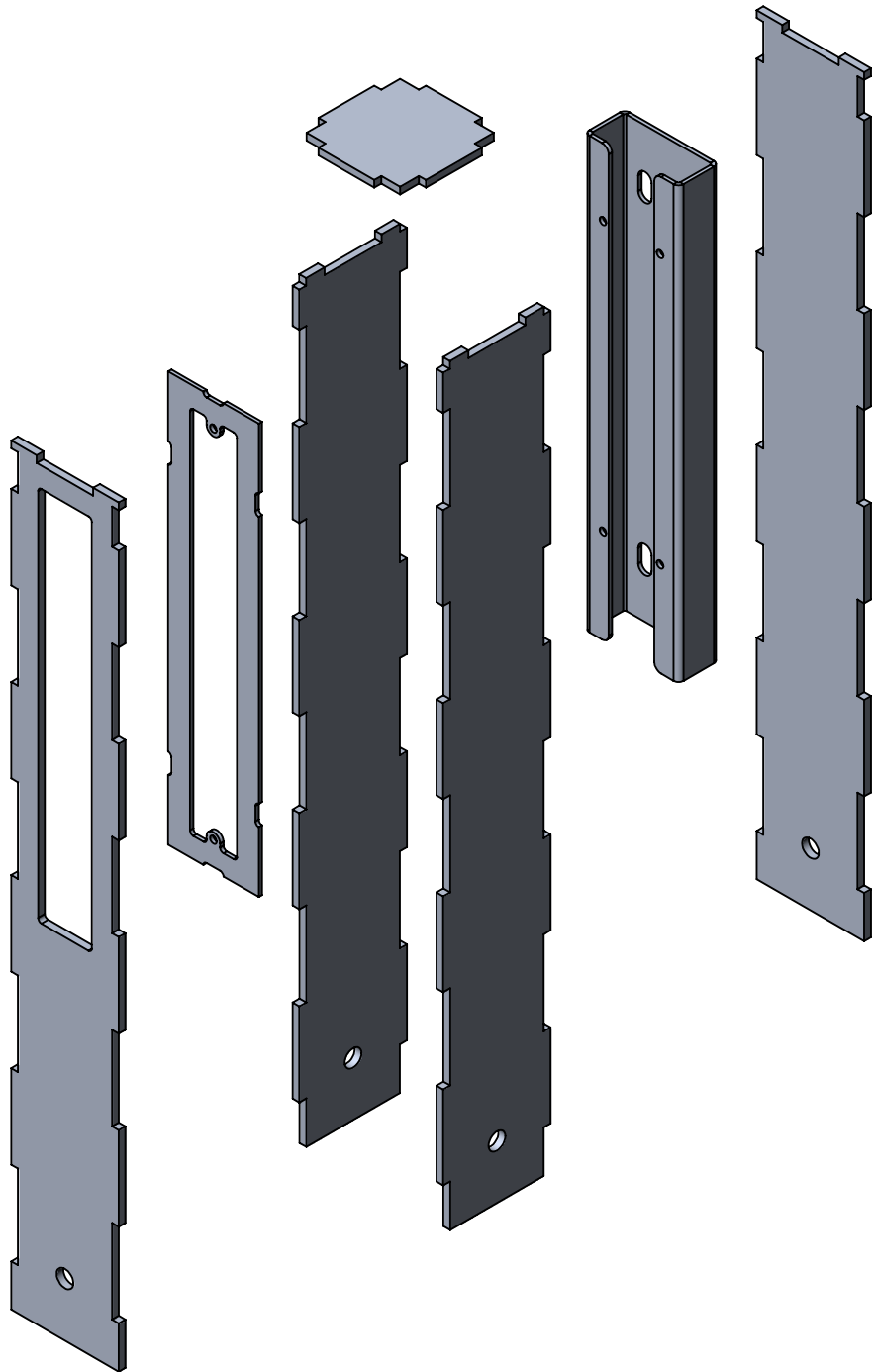

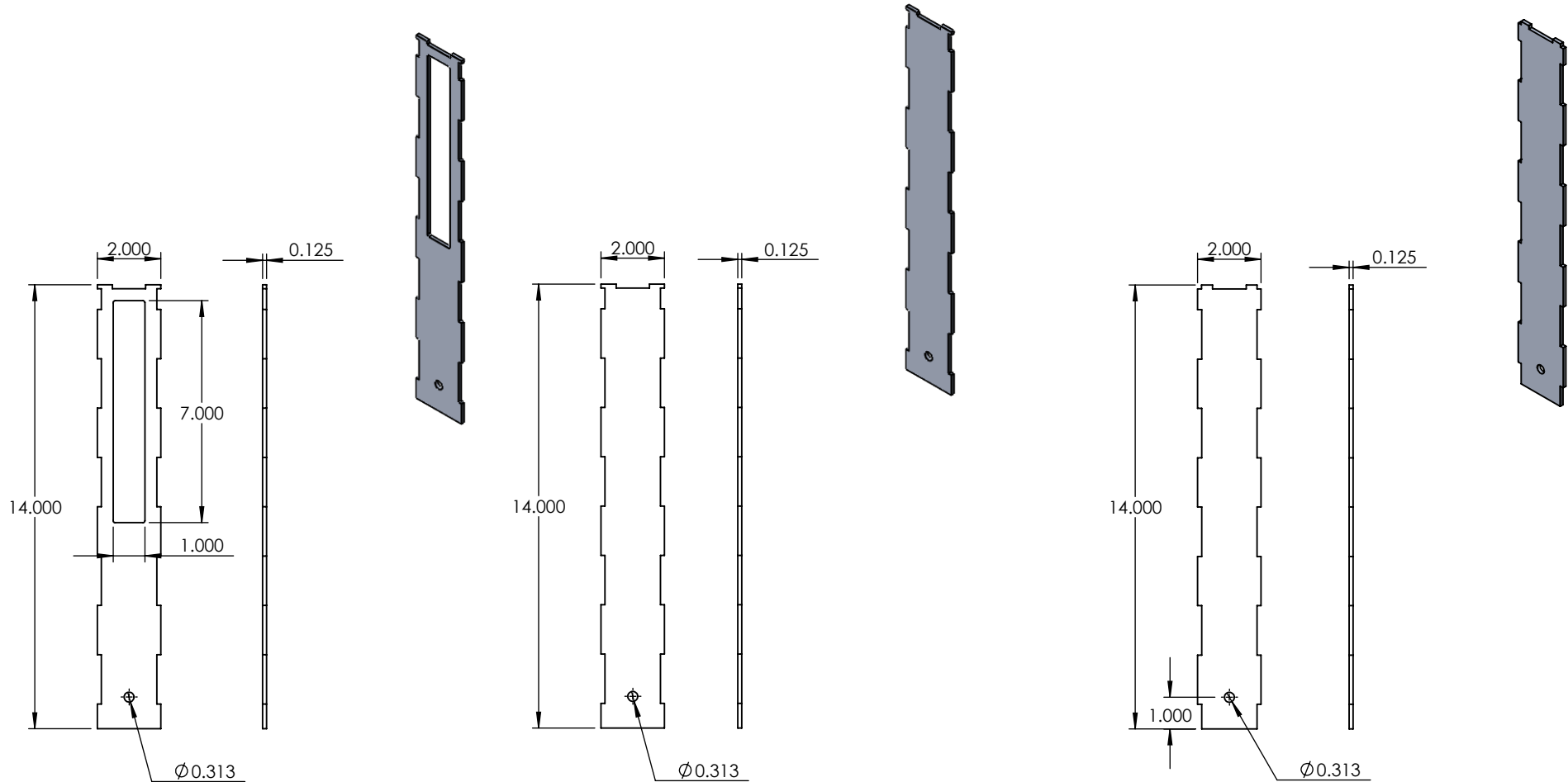

PROPRIETARY AND CONFIDENTIAL
 THE INFORMATION CONTAINED IN THIS DRAWING IS THE SOLE PROPERTY OF <INSERT COMPANY NAME HERE>. ANY REPRODUCTION IN PART OR AS A WHOLE WITHOUT THE WRITTEN PERMISSION OF <INSERT COMPANY NAME HERE> IS PROHIBITED.

		UNLESS OTHERWISE SPECIFIED:	NAME	DATE
		DIMENSIONS ARE IN INCHES	DRAWN	
		TOLERANCES:	CHECKED	
		FRACTIONAL ±	ENG APPR.	
		ANGULAR: MACH ± BEND ±	MFG APPR.	
		TWO PLACE DECIMAL ±	Q.A.	
		THREE PLACE DECIMAL ±	COMMENTS:	
		INTERPRET GEOMETRIC TOLERANCING PER:		
		MATERIAL		
NEXT ASSY	USED ON	FINISH		
APPLICATION		DO NOT SCALE DRAWING		

ALUMINUM 0.125" PLATE		
TITLE:		
POOL-HDBOL14-8W-MN-WP1-40K		
SIZE	DWG. NO.	REV
A		
SCALE: 1:5	WEIGHT:	SHEET 4 OF 6

5

4

3

2

1

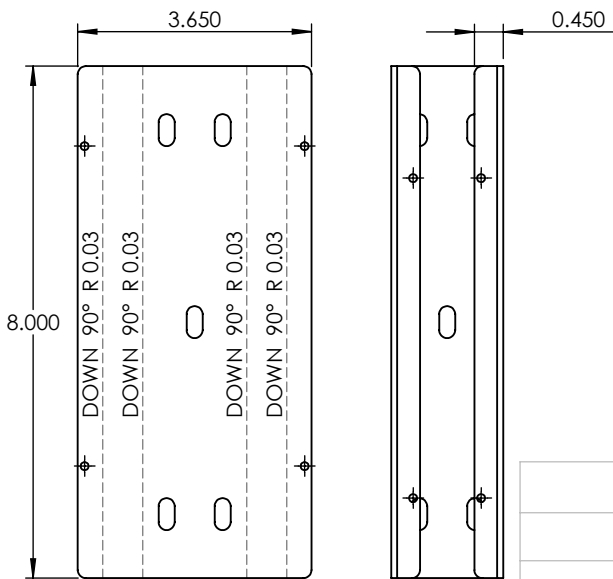
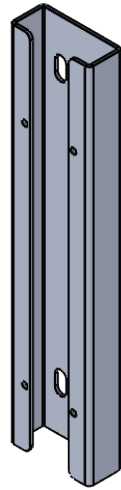
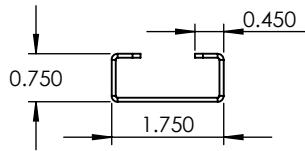
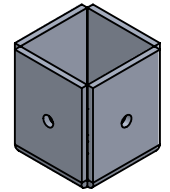
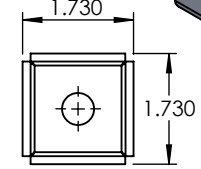
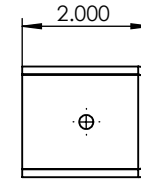
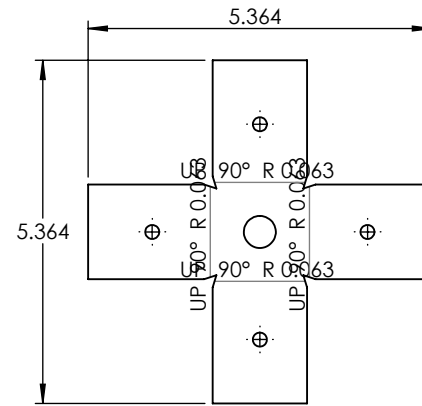
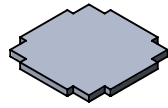
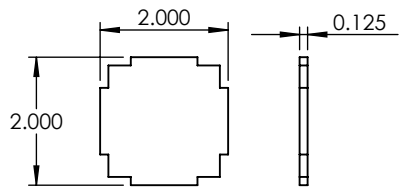

PROPRIETARY AND CONFIDENTIAL
 THE INFORMATION CONTAINED IN THIS DRAWING IS THE SOLE PROPERTY OF <INSERT COMPANY NAME HERE>. ANY REPRODUCTION IN PART OR AS A WHOLE WITHOUT THE WRITTEN PERMISSION OF <INSERT COMPANY NAME HERE> IS PROHIBITED.

		UNLESS OTHERWISE SPECIFIED:	NAME	DATE	ALUMINUM 0.125" PLATE		
		DIMENSIONS ARE IN INCHES TOLERANCES: FRACTIONAL ± ANGULAR: MACH ± BEND ± TWO PLACE DECIMAL ± THREE PLACE DECIMAL ±	DRAWN			TITLE:	
		INTERPRET GEOMETRIC TOLERANCING PER:	CHECKED		POOL-HDBOL14-8W-MN-WP1-40K		
		MATERIAL	ENG APPR.				
		FINISH	MFG APPR.		SIZE DWG. NO.	REV	
NEXT ASSY	USED ON	APPLICATION	Q.A.	COMMENTS:	SCALE: 1:3	WEIGHT:	SHEET 5 OF 6
		DO NOT SCALE DRAWING					

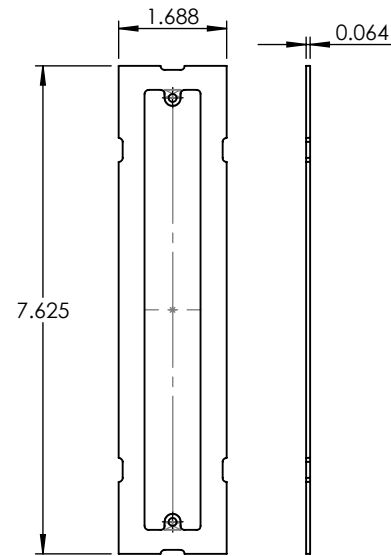
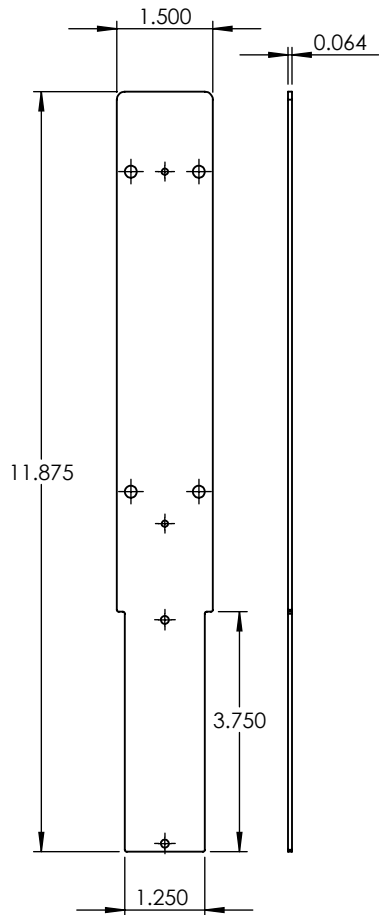

PROPRIETARY AND CONFIDENTIAL
 THE INFORMATION CONTAINED IN THIS DRAWING IS THE SOLE PROPERTY OF <INSERT COMPANY NAME HERE>. ANY REPRODUCTION IN PART OR AS A WHOLE WITHOUT THE WRITTEN PERMISSION OF <INSERT COMPANY NAME HERE> IS PROHIBITED.

		UNLESS OTHERWISE SPECIFIED:		NAME	DATE	ALUMINUM 0.0635"	
		DIMENSIONS ARE IN INCHES	DRAWN			TITLE:	
		TOLERANCES:	CHECKED			POOL-HDBOL14-8W-MN-WP1-40K	
		FRACTIONAL ±	ENG APPR.			SIZE DWG. NO. REV	
		ANGULAR: MACH ± BEND ±	MFG APPR.			SCALE: 1:3 WEIGHT: SHEET 6 OF 6	
		TWO PLACE DECIMAL ±	Q.A.				
		THREE PLACE DECIMAL ±	COMMENTS:				
		INTERPRET GEOMETRIC TOLERANCING PER:					
		MATERIAL					
	NEXT ASSY	FINISH					
		USED ON					
	APPLICATION	DO NOT SCALE DRAWING					

5

4

3

2

1