

ITEM NO.	PART NUMBER	DESCRIPTION	QTY.	CUT
1	802215LS-AB-A-30K-CANOPY	22 GAUGE	1	
2	802215LS-AB-A-30K-FIREPLATE	22 GAUGE	1	
3	802215LS-AB-A-30K-FRAME	22 GAUGE	2	
4	802215LS-AB-A-30K-FRAME BACK	22 GAUGE	1	
5	802215LS-AB-A-30K-CAP TRIM 1	22 GAUGE	2	
6	802215LS-AB-A-30K-CAP TRIM 2	22 GAUGE	2	
7	802215LS-AB-A-30K-CAP TRIM 3	22 GAUGE	1	
8	802215LS-AB-A-30K-CAP TRIM 3 TOP	22 GAUGE	1	
9	802215LS-AB-A-30K-TOP CAP	22 GAUGE	1	
10	802215LS-AB-A-30K-BOTTOM CAP	22 GAUGE	1	
11	802215LS-AB-A-30K-REFLECTOR PLATE	ALUMINUM 0.0635"	1	
12	802215LS-AB-A-30K-ACRYLIC	ACRYLIC	4	
13	802215LS-AB-A-30K-SMALL TUBE	5/8" ROUND TUBE	1	
14	802215LS-AB-A-30K-SMALL TUBE	5/8" ROUND TUBE	2	
15	BRASS L JOINT	BRASS JOINT	1	
16	Espen VEL19070MVH-1	DRIVER	1	
17	AltalLED_PN1012_RevD	LED	4	

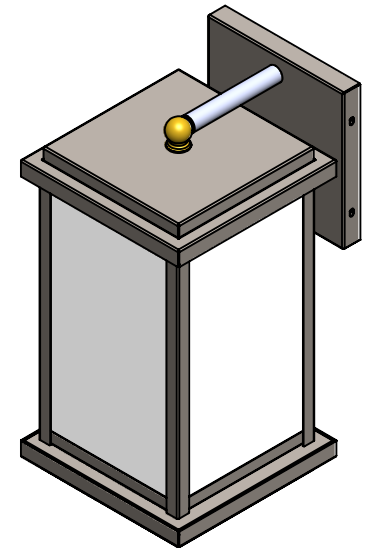
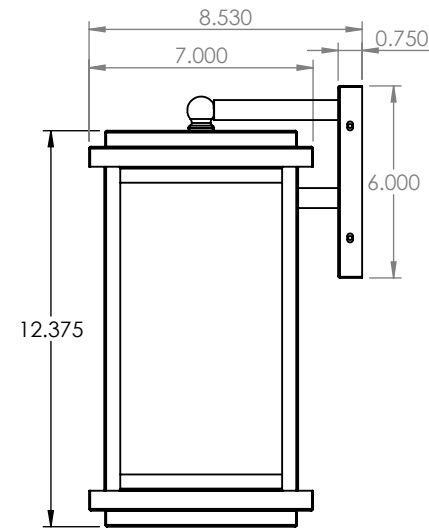
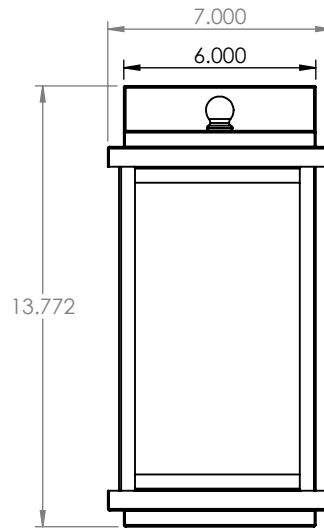

EVERGREEN LIGHTING

ALL BEND RADIUS .030"

APPLICATION

UNLESS OTHERWISE SPECIFIED:

DIMENSIONS ARE IN INCHES
 TOLERANCES:
 FRACTIONAL ± .003
 ANGULAR: MACH ± .01 BEND ±
 TWO PLACE DECIMAL ±
 THREE PLACE DECIMAL ±.001

INTERPRET GEOMETRIC
 TOLERANCING PER:
 MATERIAL

FINISH

DO NOT SCALE DRAWING

NAME

DATE

DRAWN

CHECKED

ENG APPR.

MFG APPR.

Q.A.

COMMENTS:

TITLE:

802215LS-AB-A-30K

SIZE DWG. NO.

A TICKET 27142

REV

SCALE: 1:7.5WEIGHT:

SHEET 1 OF 10

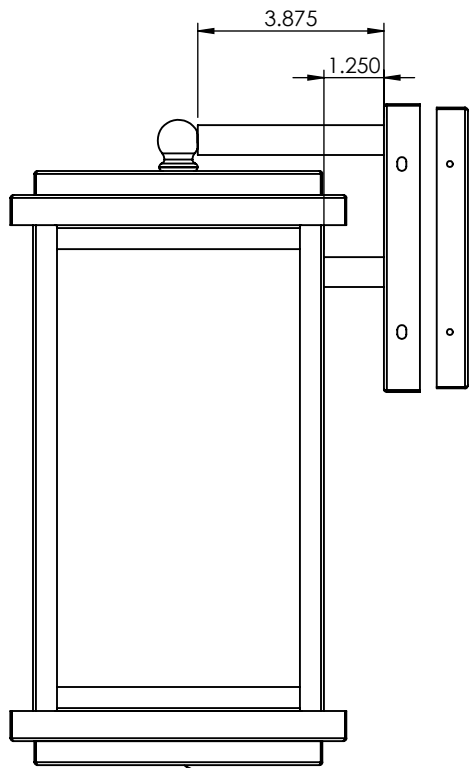

BOTTOM HAS HAS OPENNING

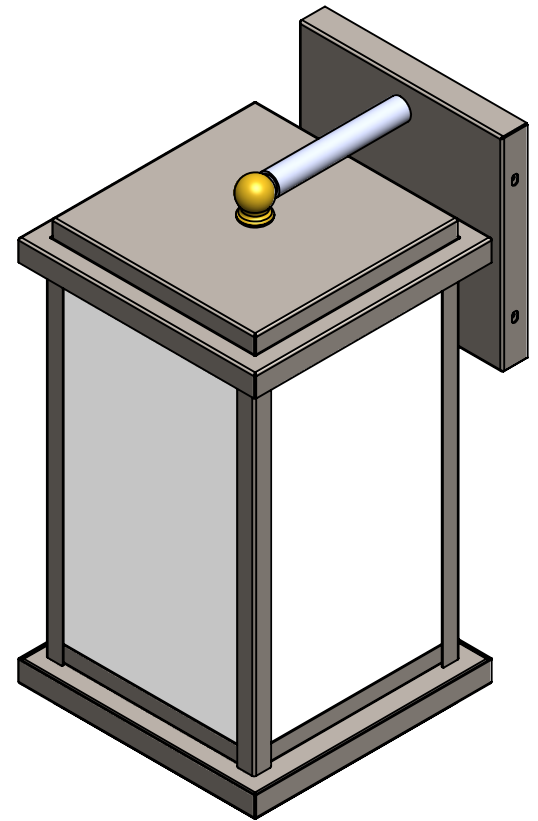
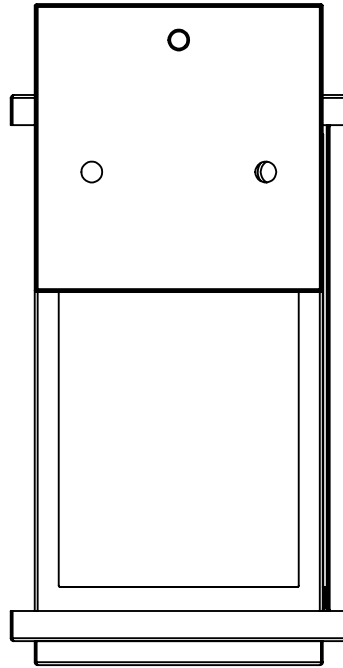

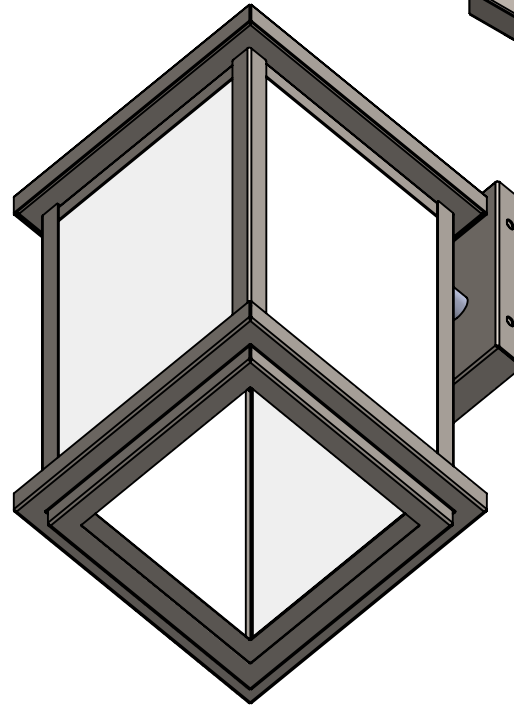
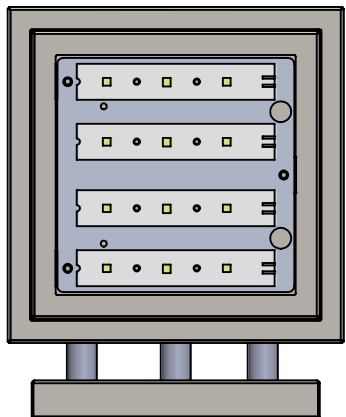
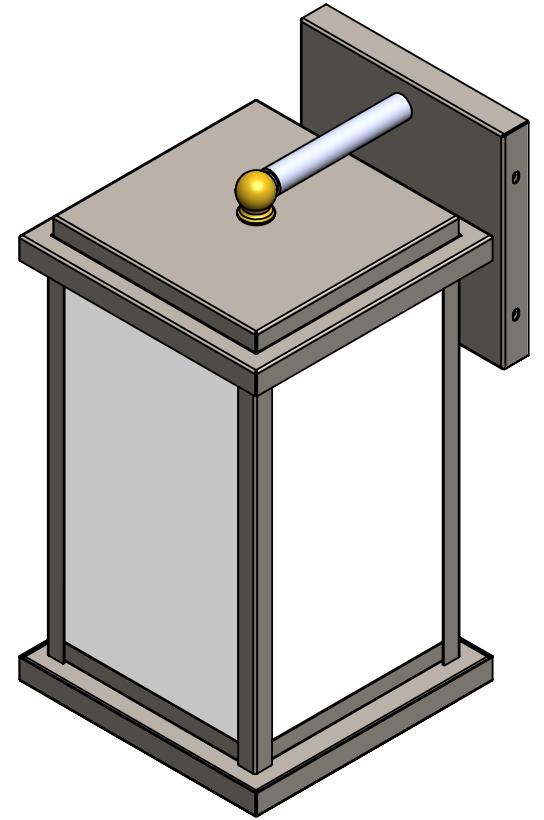
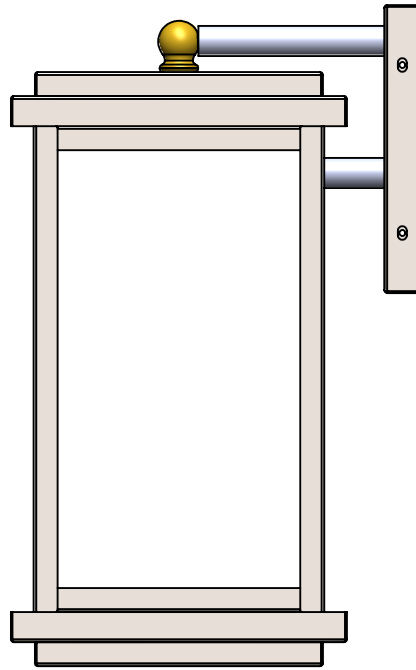
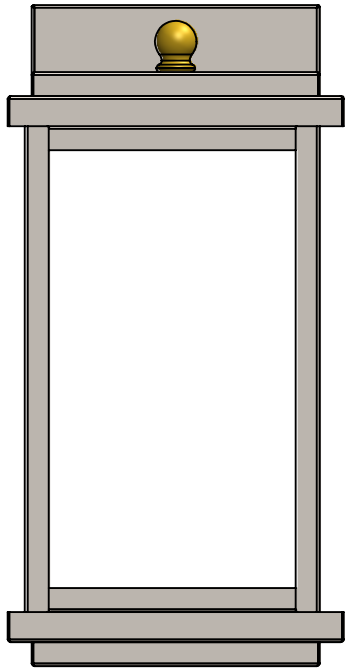

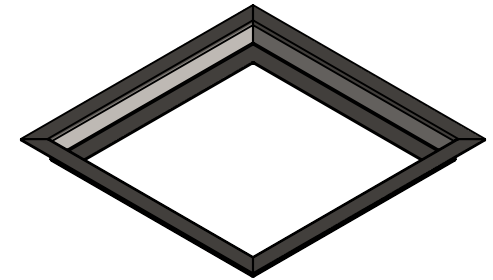
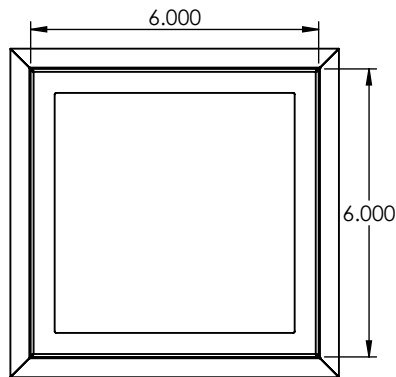
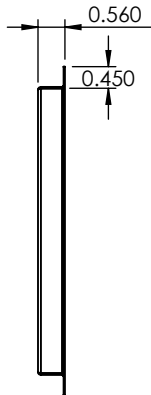
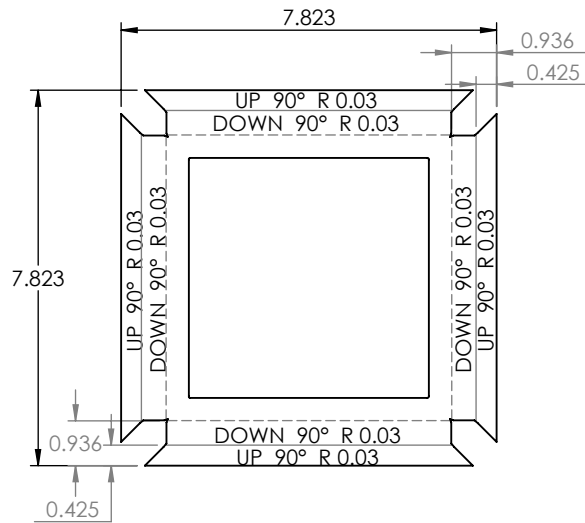
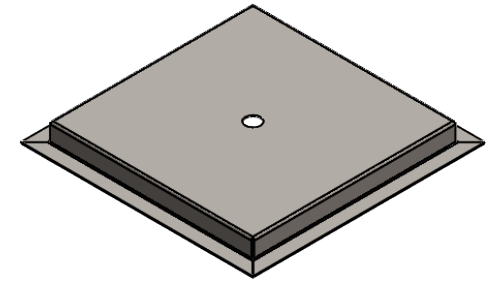
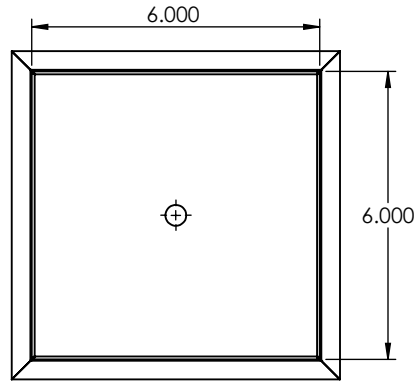
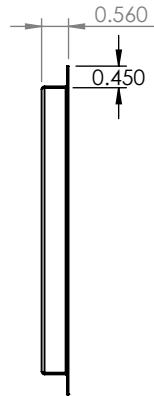
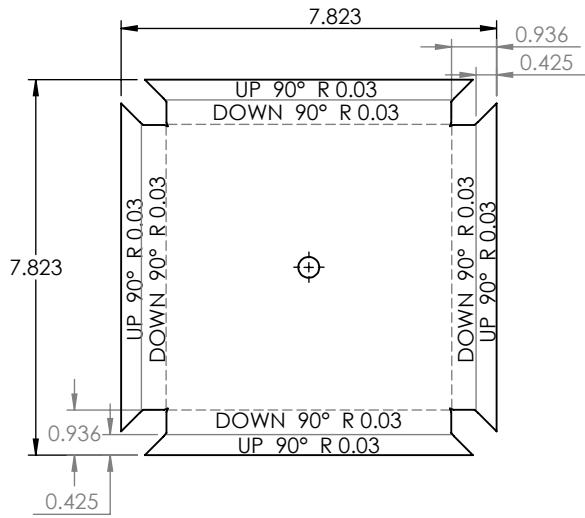

PROPRIETARY AND CONFIDENTIAL
 THE INFORMATION CONTAINED IN THIS DRAWING IS THE SOLE PROPERTY OF <INSERT COMPANY NAME HERE>. ANY REPRODUCTION IN PART OR AS A WHOLE WITHOUT THE WRITTEN PERMISSION OF <INSERT COMPANY NAME HERE> IS PROHIBITED.

NEXT ASSY	USED ON
APPLICATION	

UNLESS OTHERWISE SPECIFIED:
DIMENSIONS ARE IN INCHES
TOLERANCES:
FRACTIONAL ±
ANGULAR: MACH ± BEND ±
TWO PLACE DECIMAL ±
THREE PLACE DECIMAL ±
INTERPRET GEOMETRIC TOLERANCING PER:
MATERIAL
FINISH
DO NOT SCALE DRAWING

	NAME	DATE
DRAWN		
CHECKED		
ENG APPR.		
MFG APPR.		
Q.A.		
COMMENTS:		

22 GAUGE		
TITLE:		
802215LS-AB-A-30K		
SIZE	DWG. NO.	REV
A		
SCALE: 1:4	WEIGHT:	SHEET 4 OF 10

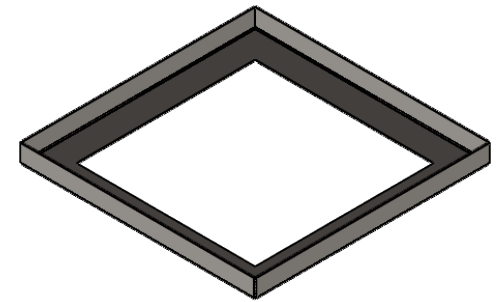
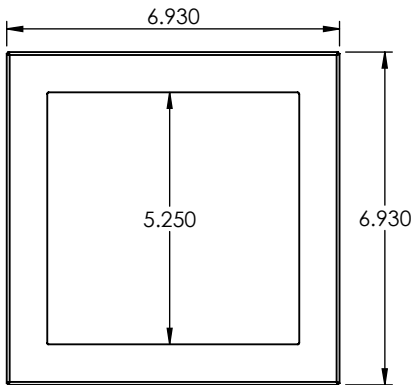
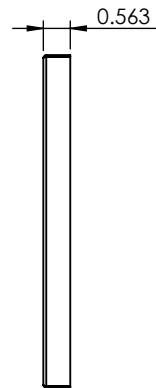
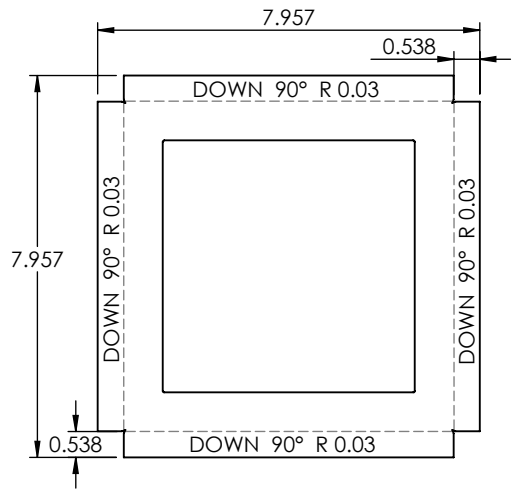
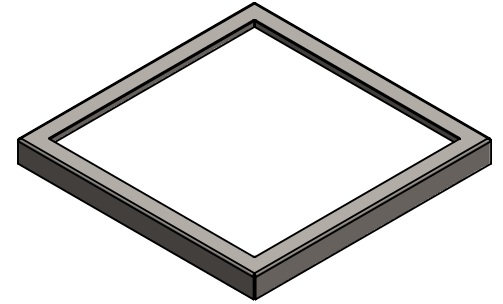
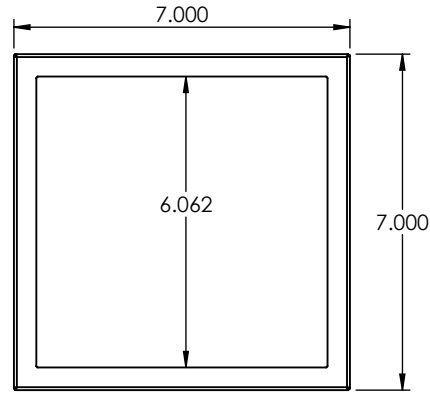
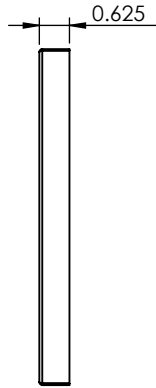
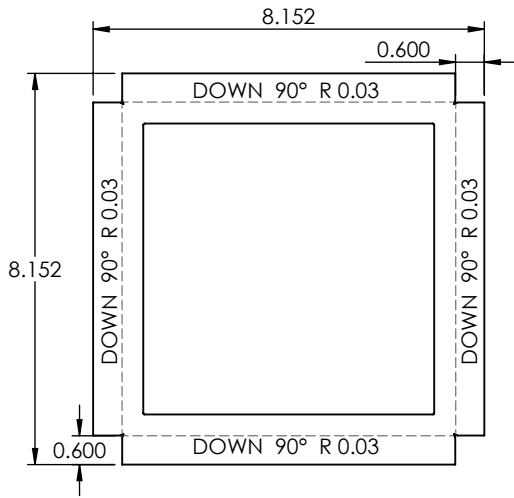

PROPRIETARY AND CONFIDENTIAL
 THE INFORMATION CONTAINED IN THIS DRAWING IS THE SOLE PROPERTY OF <INSERT COMPANY NAME HERE>. ANY REPRODUCTION IN PART OR AS A WHOLE WITHOUT THE WRITTEN PERMISSION OF <INSERT COMPANY NAME HERE> IS PROHIBITED.

NEXT ASSY	USED ON
APPLICATION	

UNLESS OTHERWISE SPECIFIED:
DIMENSIONS ARE IN INCHES
TOLERANCES:
FRACTIONAL ±
ANGULAR: MACH ± BEND ±
TWO PLACE DECIMAL ±
THREE PLACE DECIMAL ±
INTERPRET GEOMETRIC TOLERANCING PER:
MATERIAL
FINISH
DO NOT SCALE DRAWING

	NAME	DATE
DRAWN		
CHECKED		
ENG APPR.		
MFG APPR.		
Q.A.		
COMMENTS:		

22 GAUGE		
TITLE:		
802215LS-AB-A-30K		
SIZE	DWG. NO.	REV
A		
SCALE: 1:4	WEIGHT:	SHEET 5 OF 10

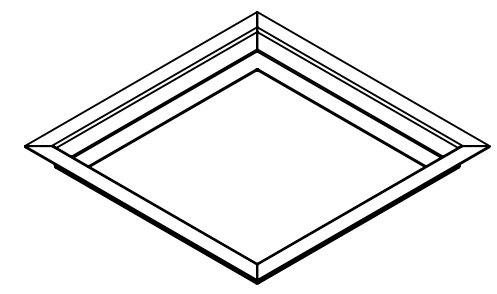
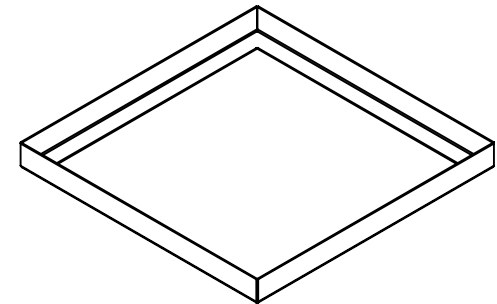
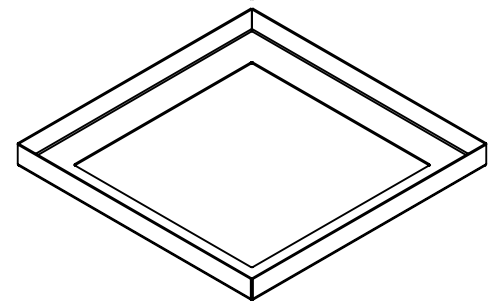
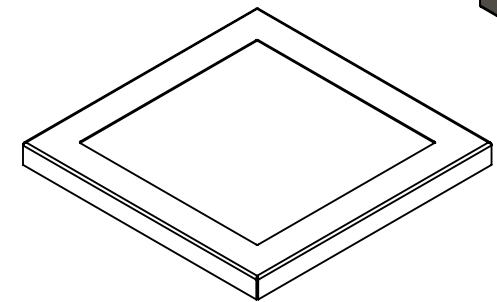
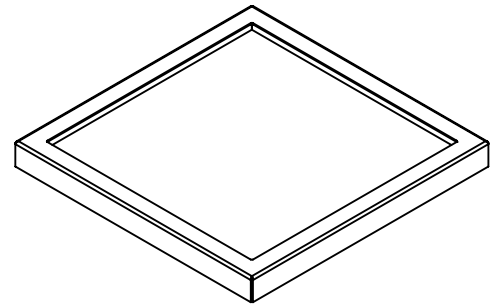
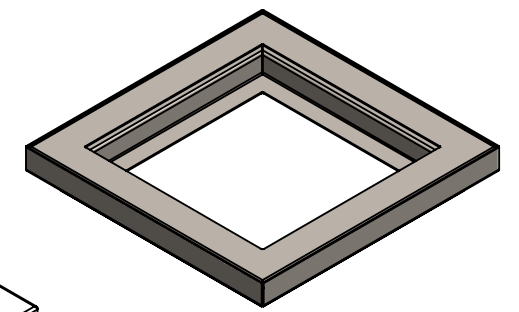
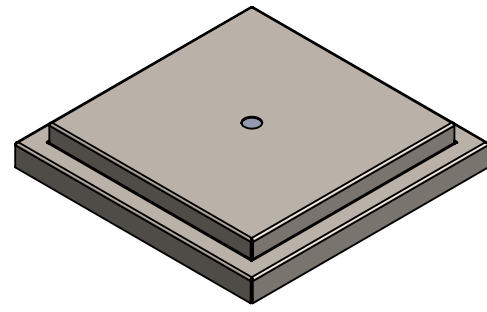
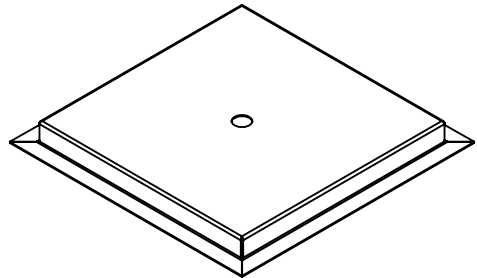

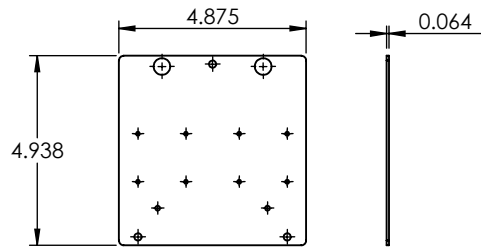
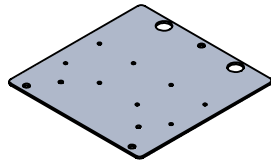
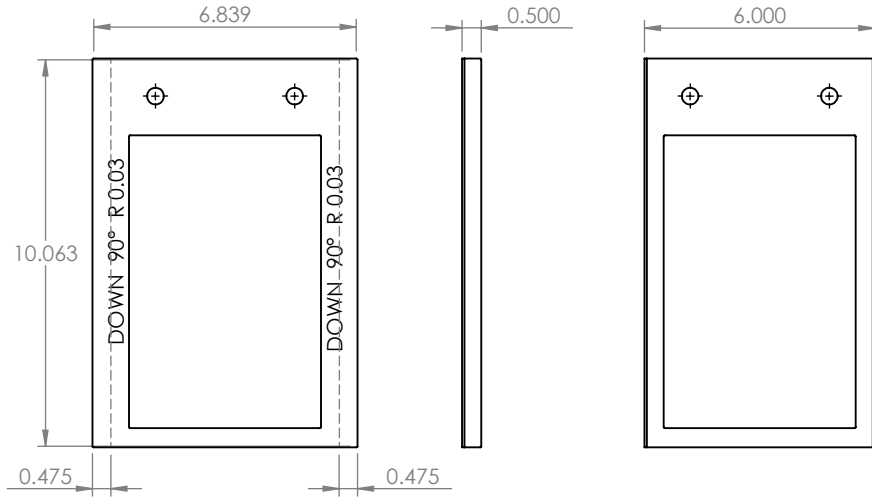
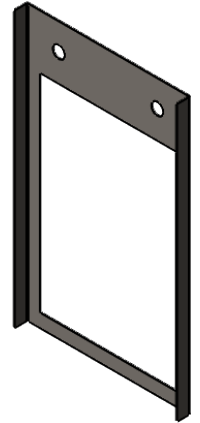
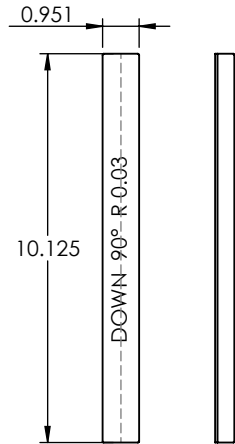
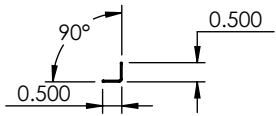

UNLESS OTHERWISE SPECIFIED:		NAME	DATE	22 GAUGE	
DIMENSIONS ARE IN INCHES TOLERANCES: FRACTIONAL ± ANGULAR: MACH ± BEND ± TWO PLACE DECIMAL ± THREE PLACE DECIMAL ±		DRAWN			
INTERPRET GEOMETRIC TOLERANCING PER: MATERIAL		CHECKED		SIZE DWG. NO. REV	
		ENG APPR.			
FINISH		MFG APPR.		SCALE: 1:5 WEIGHT: SHEET 7 OF 10	
		Q.A.			
APPLICATION		COMMENTS:			
NEXT ASSY	USED ON				
DO NOT SCALE DRAWING					

PROPRIETARY AND CONFIDENTIAL
THE INFORMATION CONTAINED IN THIS DRAWING IS THE SOLE PROPERTY OF <INSERT COMPANY NAME HERE>. ANY REPRODUCTION IN PART OR AS A WHOLE WITHOUT THE WRITTEN PERMISSION OF <INSERT COMPANY NAME HERE> IS PROHIBITED.

5

4

3

2

1

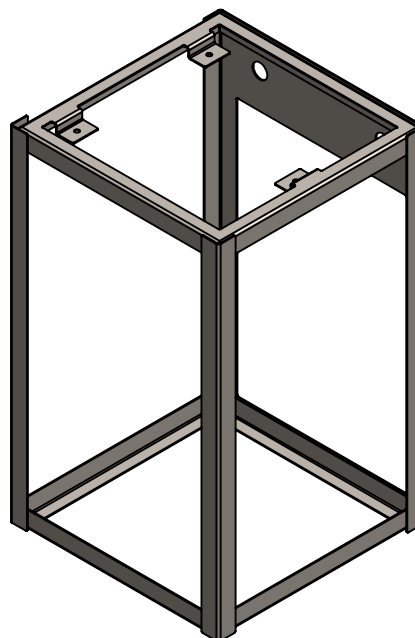
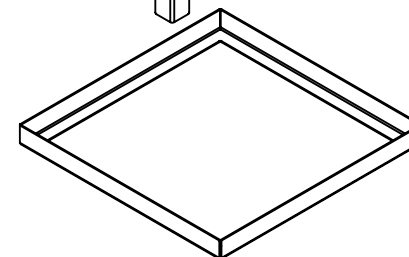
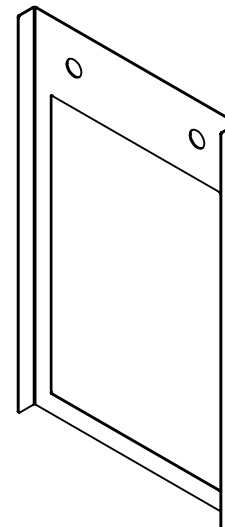
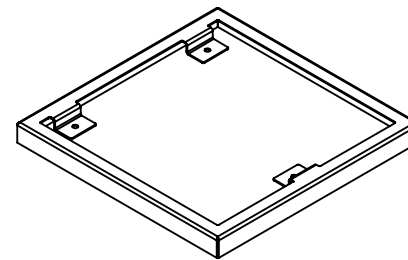
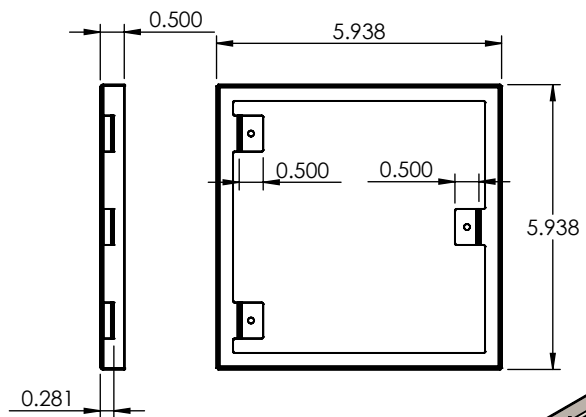
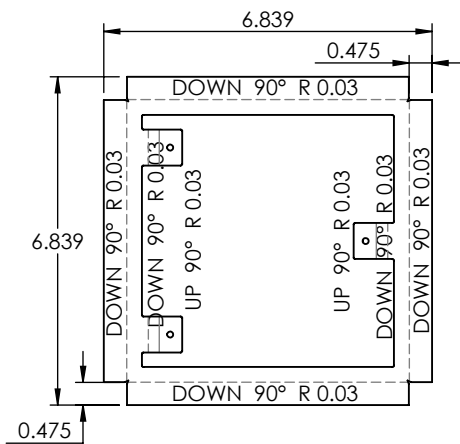
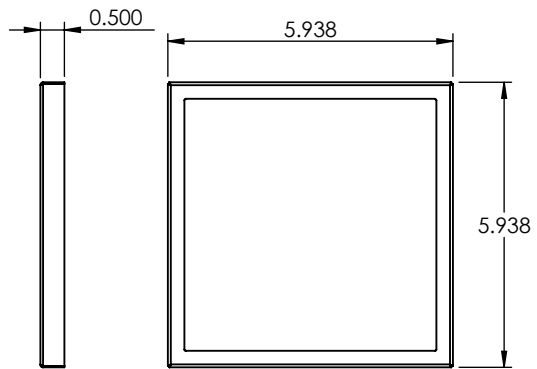
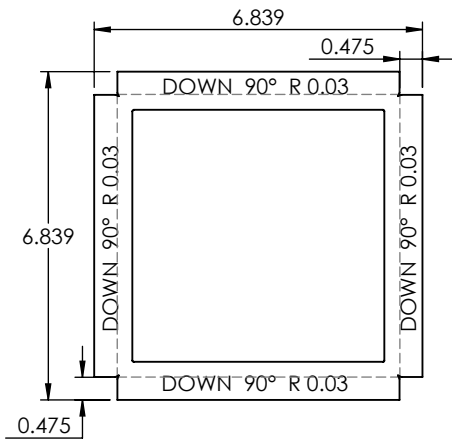

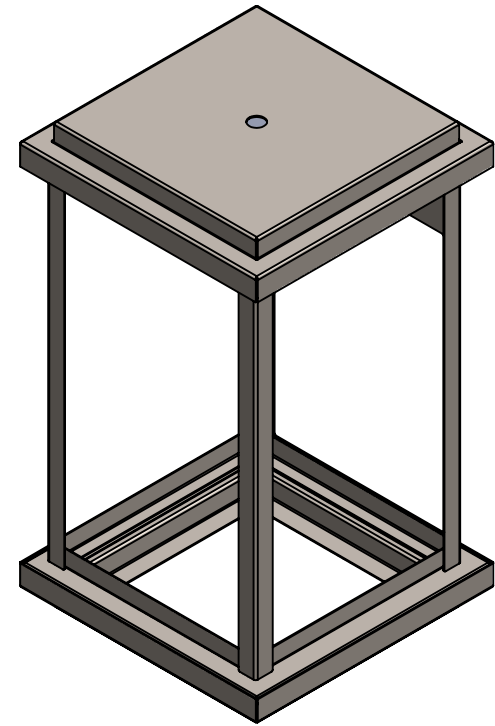
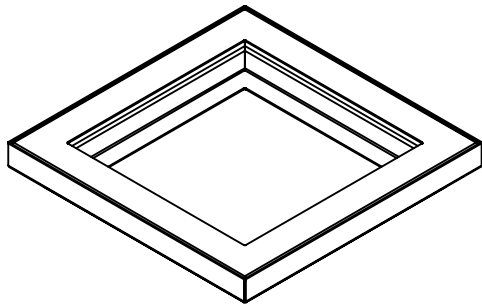
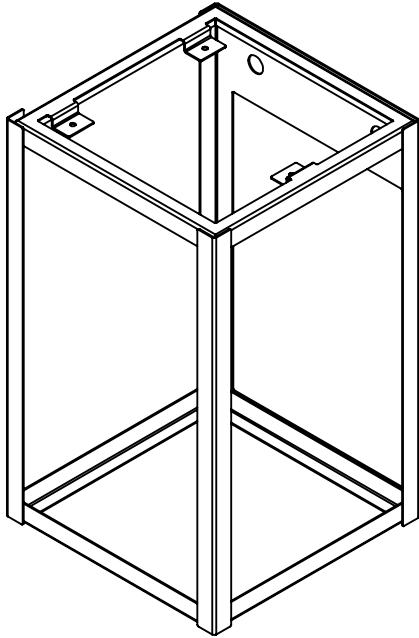
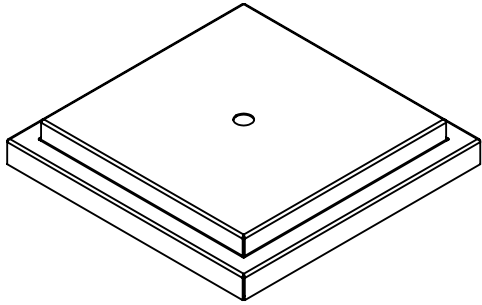

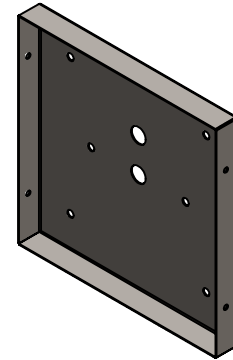
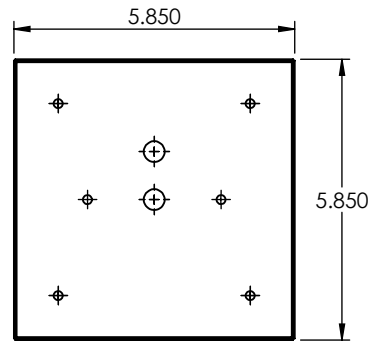
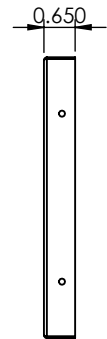
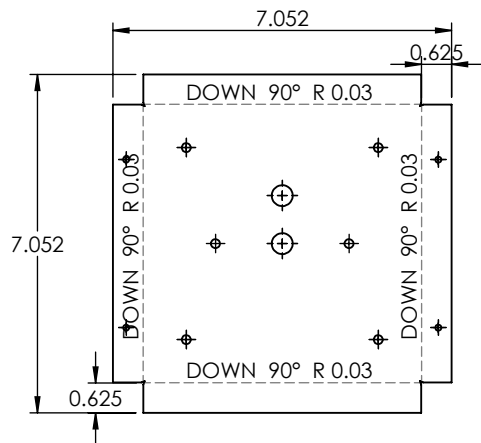
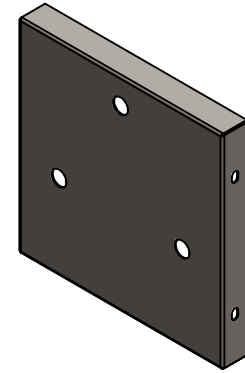
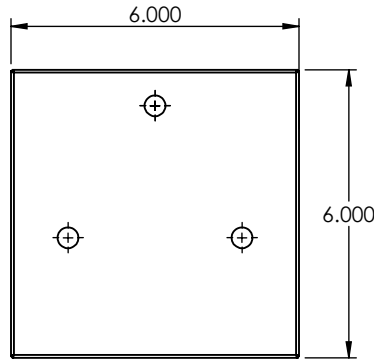
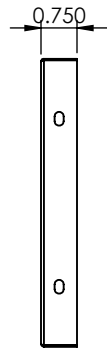
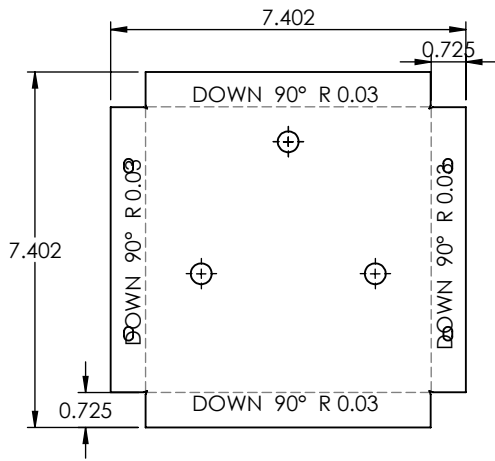

PROPRIETARY AND CONFIDENTIAL
 THE INFORMATION CONTAINED IN THIS DRAWING IS THE SOLE PROPERTY OF <INSERT COMPANY NAME HERE>. ANY REPRODUCTION IN PART OR AS A WHOLE WITHOUT THE WRITTEN PERMISSION OF <INSERT COMPANY NAME HERE> IS PROHIBITED.

NEXT ASSY	USED ON
APPLICATION	

UNLESS OTHERWISE SPECIFIED:	NAME	DATE
DIMENSIONS ARE IN INCHES	DRAWN	
TOLERANCES:	CHECKED	
FRACTIONAL ±	ENG APPR.	
ANGULAR: MACH ± BEND ±	MFG APPR.	
TWO PLACE DECIMAL ±	Q.A.	
THREE PLACE DECIMAL ±	COMMENTS:	
INTERPRET GEOMETRIC TOLERANCING PER:		
MATERIAL		
FINISH		
DO NOT SCALE DRAWING		

22 GAUGE		
TITLE:		
802215LS-AB-A-30K		
SIZE	DWG. NO.	REV
A		
SCALE: 1:4	WEIGHT:	SHEET 10 OF 10