

UNLESS OTHERWISE SPECIFIED:		NAME	DATE		
DIMENSIONS ARE IN INCHES TOLERANCES: FRACTIONAL ± .003 ANGULAR: MACH ± .01 BEND ± TWO PLACE DECIMAL ± THREE PLACE DECIMAL ±.001		DRAWN		TITLE:	
INTERPRET GEOMETRIC TOLERANCING PER:		CHECKED		WNWL-12W-MN-WF-STBL-WET-12"-DIM-27	
MATERIAL		ENG APPR.			
FINISH		MFG APPR.		SIZE	DWG. NO.
APPLICATION		Q.A.		A	TICKET 27151
DO NOT SCALE DRAWING		COMMENTS:		SCALE: 1:7	WEIGHT:
				SHEET 1 OF 8	



EVERGREEN LIGHTING

5

4

3

2

1

ITEM NO.	PART NUMBER	DESCRIPTION	QTY.	CUT
1	WNWL-12W-MN-WF-STBL-WET-12"-DIM-27K-FRAME	22 GAUGE	1	
2	WNWL-12W-MN-WF-STBL-WET-12"-DIM-27K-BACKPLATE	22 GAUGE	1	
3	WNWL-12W-MN-WF-STBL-WET-12"-DIM-27K-LED SPACER	22 GAUGE	1	
4	WNWL-12W-MN-WF-STBL-WET-12"-DIM-27K-FIREPLATE	22 GAUGE	1	
5	WNWL-12W-MN-WF-STBL-WET-12"-DIM-27K-LONG RAIL	22 GAUGE	2	
6	WNWL-12W-MN-WF-STBL-WET-12"-DIM-27K-SHORT RAIL	22 GAUGE	1	
7	WNWL-12W-MN-WF-STBL-WET-12"-DIM-27K-FRAME TAB	22 GAUGE	4	
8	WNWL-12W-MN-WF-STBL-WET-12"-DIM-27K-OPEN BOTTOM	22 GAUGE	1	
9	WNWL-12W-MN-WF-STBL-WET-12"-DIM-27K-SHORT RAIL STRAP	22 GAUGE	1	
10	WNWL-12W-MN-WF-STBL-WET-12"-DIM-27K-VERTICAL STRAP	ALUMINUM 0.250" FLAT BAR	1	
11	WNWL-12W-MN-WF-STBL-WET-12"-DIM-27K-ALUMINUM PLATE	ALUMINUM 0.250" PLATE	4	
12	WNWL-12W-MN-WF-STBL-WET-12"-DIM-27K-ACRYLIC	ACRYLIC	1	
13	.750 BRASS CYLINDER	3/4" BRASS CYLINDER	2	
14	KTLD-25-UV-700-VDIM-LA1	DRIVER	1	
15	AltaiLED_PN1004RevD	LED	2	

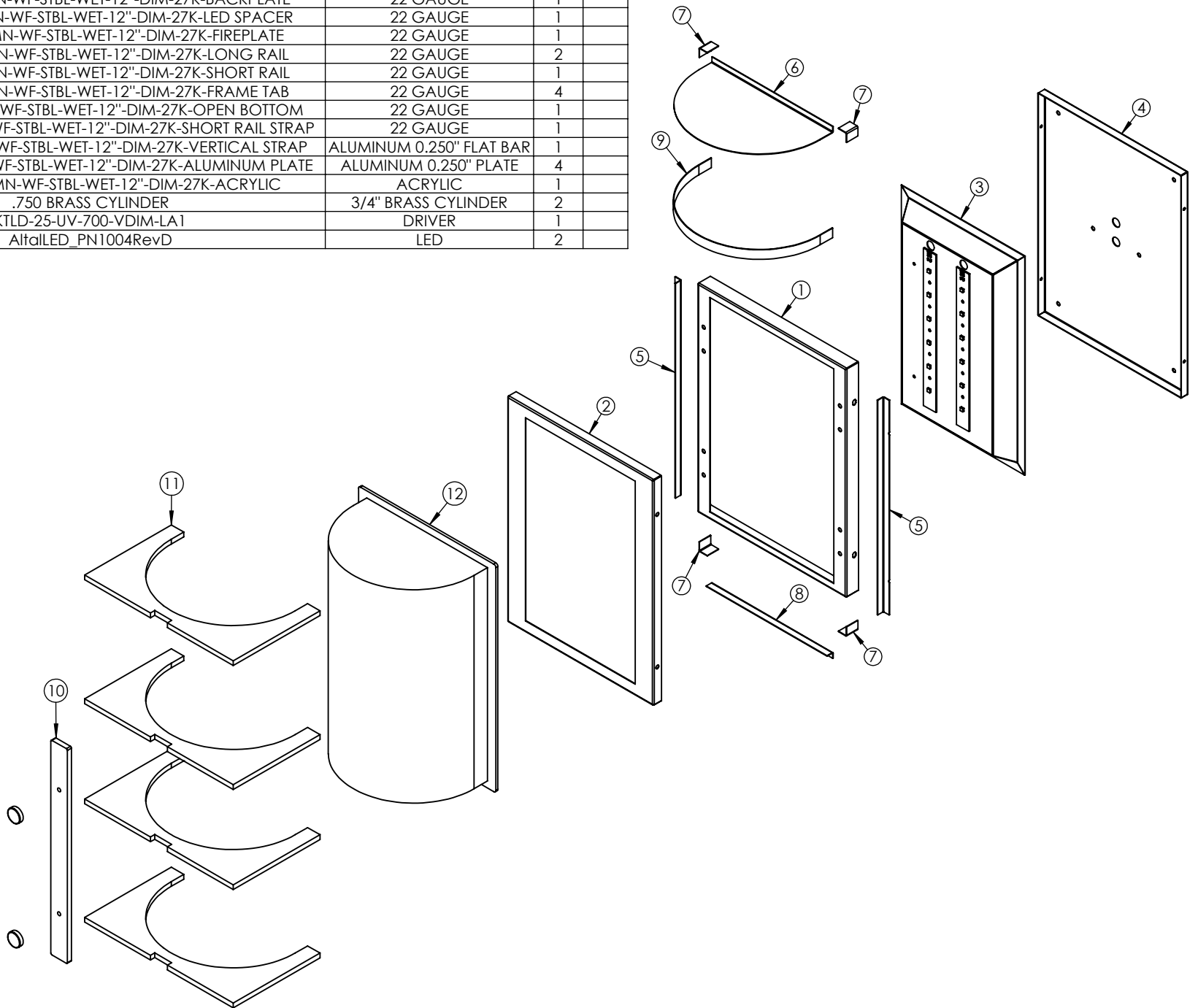

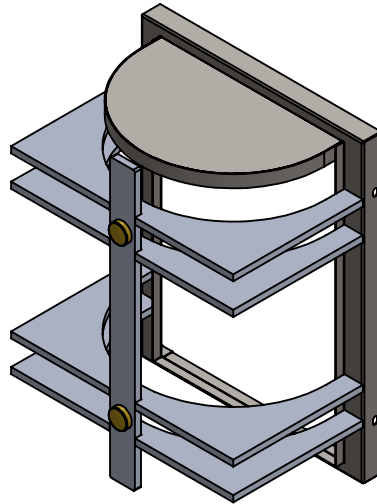
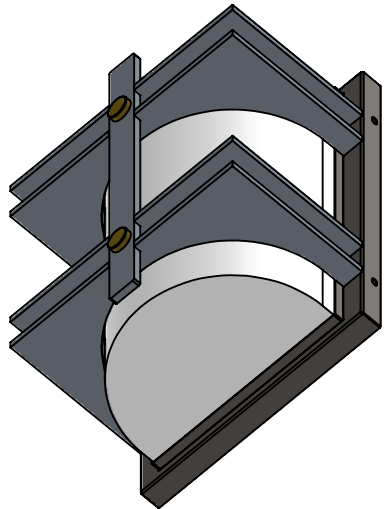
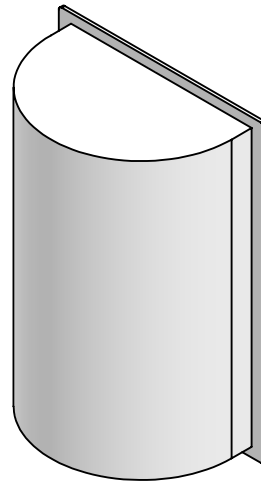
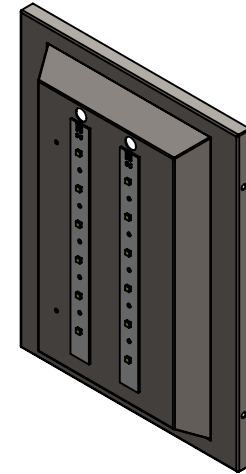
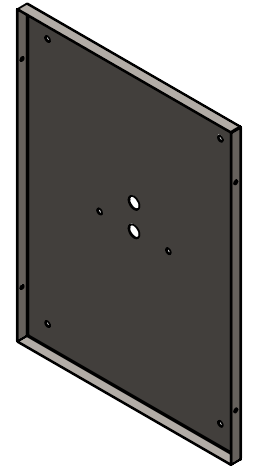
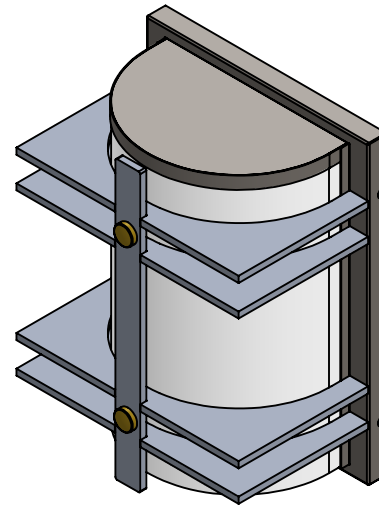
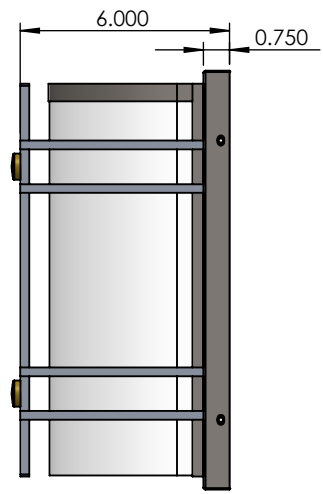
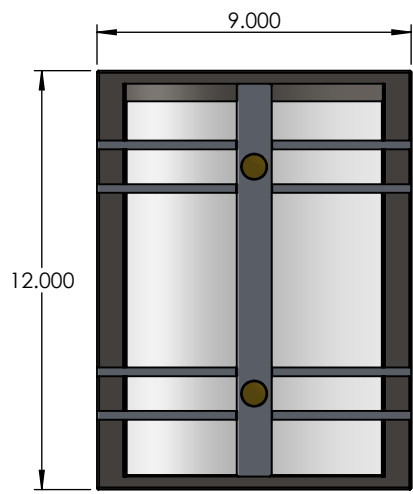

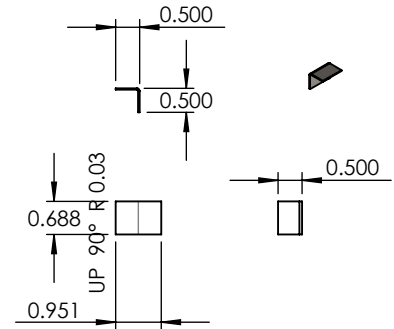
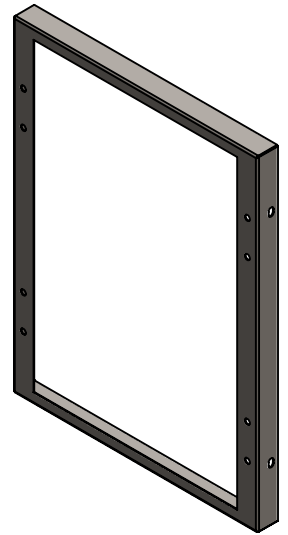
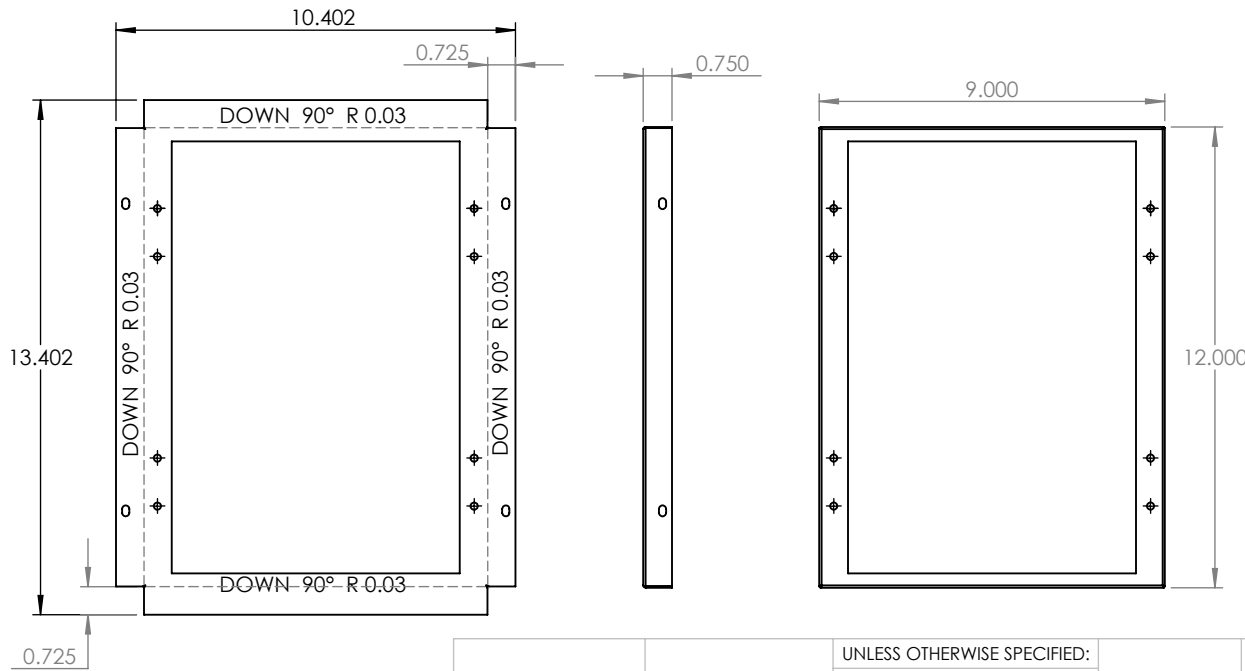

PROPRIETARY AND CONFIDENTIAL
 THE INFORMATION CONTAINED IN THIS DRAWING IS THE SOLE PROPERTY OF <INSERT COMPANY NAME HERE>. ANY REPRODUCTION IN PART OR AS A WHOLE WITHOUT THE WRITTEN PERMISSION OF <INSERT COMPANY NAME HERE> IS PROHIBITED.

		UNLESS OTHERWISE SPECIFIED:	NAME	DATE
		DIMENSIONS ARE IN INCHES	DRAWN	
		TOLERANCES:	CHECKED	
		FRACTIONAL ±	ENG APPR.	
		ANGULAR: MACH ± BEND ±	MFG APPR.	
		TWO PLACE DECIMAL ±	Q.A.	
		THREE PLACE DECIMAL ±	COMMENTS:	
		INTERPRET GEOMETRIC TOLERANCING PER:		
		MATERIAL		
NEXT ASSY	USED ON	FINISH		
APPLICATION		DO NOT SCALE DRAWING		

22 GAUGE

TITLE:
 WNWL-12W-MN-WF-STBL-WET-12"-DIM-27K

SIZE	DWG. NO.	REV
A		
SCALE: 1:5	WEIGHT:	SHEET 4 OF 8

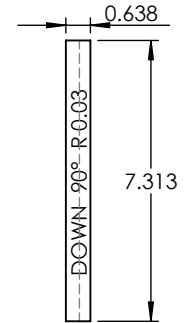
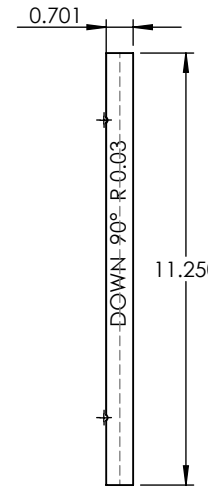
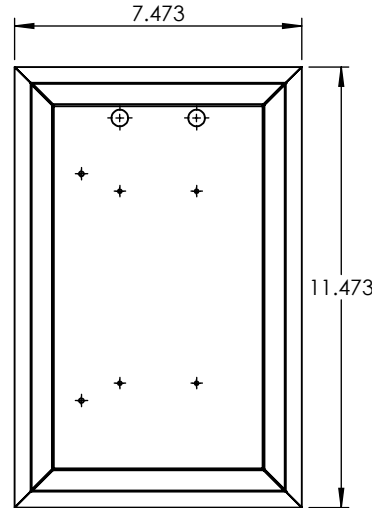
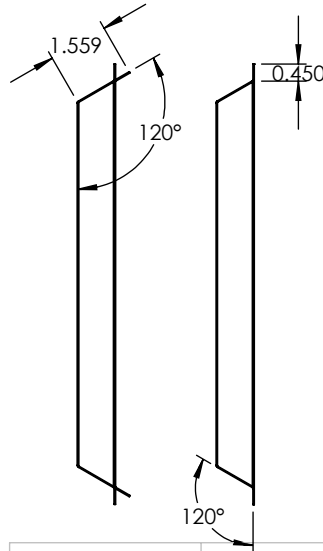
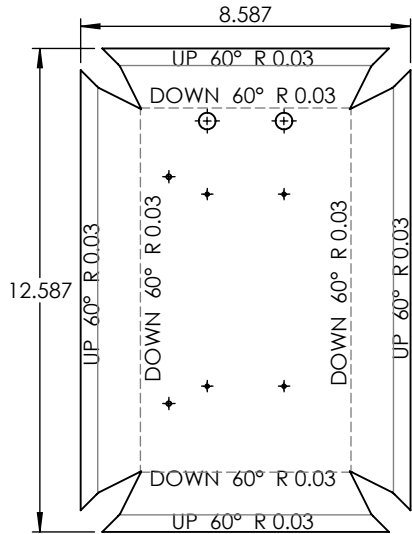
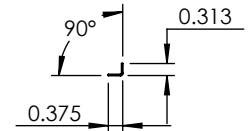
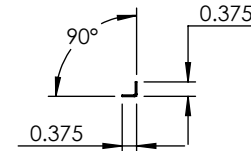
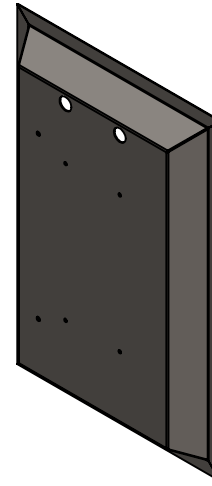
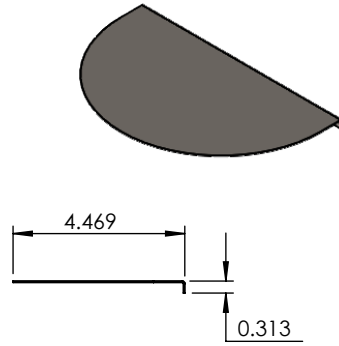
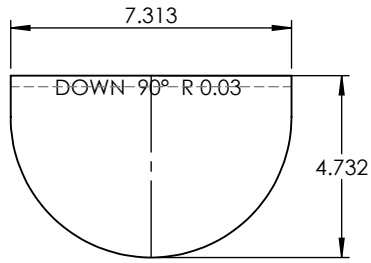

PROPRIETARY AND CONFIDENTIAL
 THE INFORMATION CONTAINED IN THIS DRAWING IS THE SOLE PROPERTY OF <INSERT COMPANY NAME HERE>. ANY REPRODUCTION IN PART OR AS A WHOLE WITHOUT THE WRITTEN PERMISSION OF <INSERT COMPANY NAME HERE> IS PROHIBITED.

		UNLESS OTHERWISE SPECIFIED:	NAME	DATE
		DIMENSIONS ARE IN INCHES	DRAWN	
		TOLERANCES:	CHECKED	
		FRACTIONAL ±	ENG APPR.	
		ANGULAR: MACH ± BEND ±	MFG APPR.	
		TWO PLACE DECIMAL ±	Q.A.	
		THREE PLACE DECIMAL ±	COMMENTS:	
		INTERPRET GEOMETRIC TOLERANCING PER:		
		MATERIAL		
NEXT ASSY	USED ON	FINISH		
APPLICATION		DO NOT SCALE DRAWING		

22 GAUGE

TITLE:
 WNWL-12W-MN-WF-STBL-WET-12"-DIM-27K

SIZE	DWG. NO.	REV
A		
SCALE: 1:5	WEIGHT:	SHEET 5 OF 8

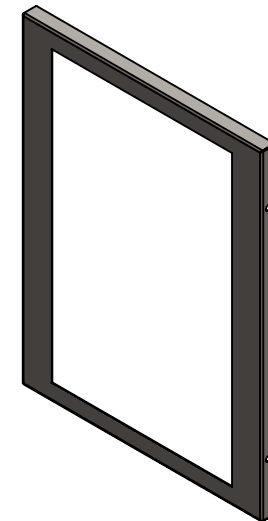
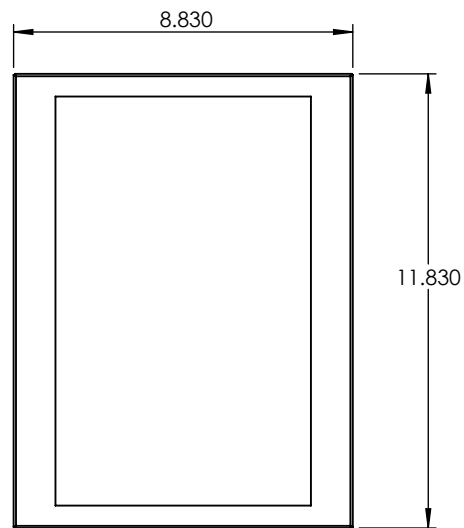
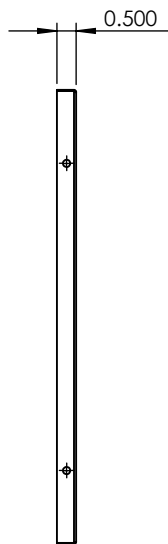
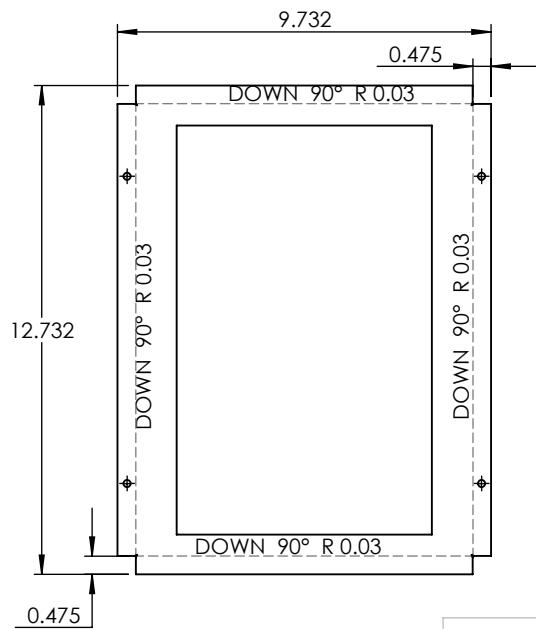

PROPRIETARY AND CONFIDENTIAL
 THE INFORMATION CONTAINED IN THIS DRAWING IS THE SOLE PROPERTY OF <INSERT COMPANY NAME HERE>. ANY REPRODUCTION IN PART OR AS A WHOLE WITHOUT THE WRITTEN PERMISSION OF <INSERT COMPANY NAME HERE> IS PROHIBITED.

		UNLESS OTHERWISE SPECIFIED:		NAME	DATE
		DIMENSIONS ARE IN INCHES	DRAWN		
		TOLERANCES:	CHECKED		
		FRACTIONAL ±	ENG APPR.		
		ANGULAR: MACH ± BEND ±	MFG APPR.		
		TWO PLACE DECIMAL ±	Q.A.		
		THREE PLACE DECIMAL ±	COMMENTS:		
		INTERPRET GEOMETRIC TOLERANCING PER:			
		MATERIAL			
		FINISH			
NEXT ASSY	USED ON				
APPLICATION		DO NOT SCALE DRAWING			

22 GAUGE

TITLE:
 WNWL-12W-MN-WF-STBL-WET-12"-DIM-27K

SIZE	DWG. NO.	REV
A		
SCALE: 1:5	WEIGHT:	SHEET 6 OF 8

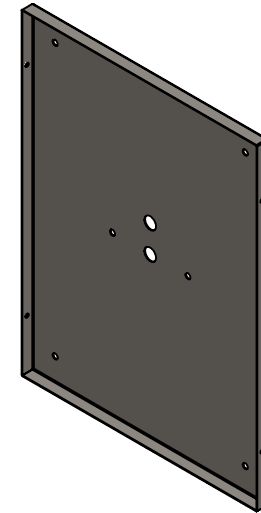
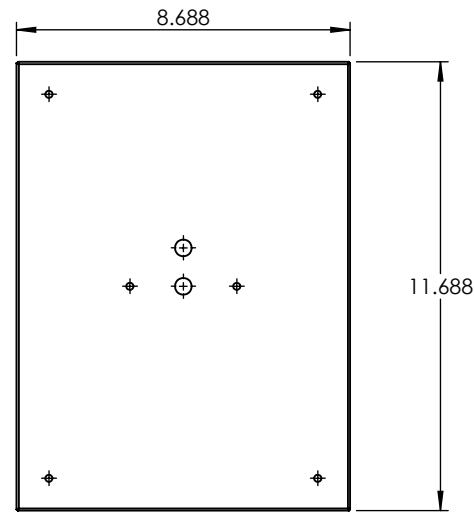
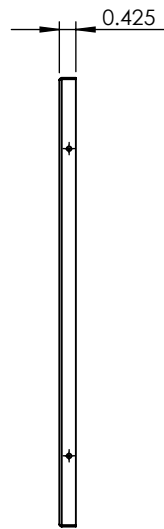
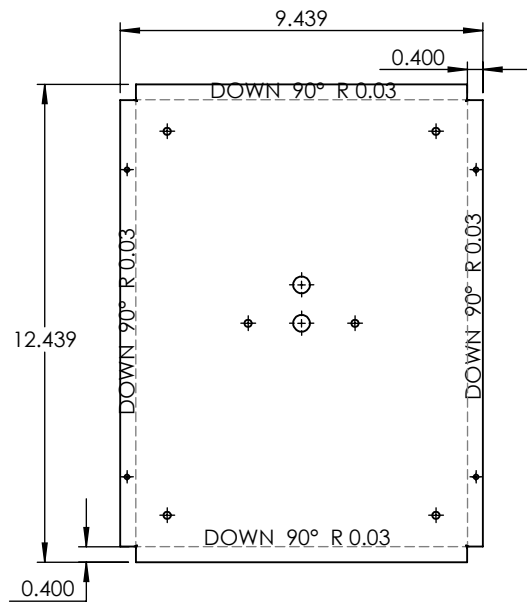

PROPRIETARY AND CONFIDENTIAL
 THE INFORMATION CONTAINED IN THIS DRAWING IS THE SOLE PROPERTY OF <INSERT COMPANY NAME HERE>. ANY REPRODUCTION IN PART OR AS A WHOLE WITHOUT THE WRITTEN PERMISSION OF <INSERT COMPANY NAME HERE> IS PROHIBITED.

		UNLESS OTHERWISE SPECIFIED:		NAME	DATE	22 GAUGE	
		DIMENSIONS ARE IN INCHES TOLERANCES: FRACTIONAL ± ANGULAR: MACH ± BEND ± TWO PLACE DECIMAL ± THREE PLACE DECIMAL ±		DRAWN			
		INTERPRET GEOMETRIC TOLERANCING PER:		CHECKED		SIZE DWG. NO. REV	
		MATERIAL		ENG APPR.			
		FINISH		MFG APPR.		COMMENTS:	
NEXT ASSY	USED ON			Q.A.			
APPLICATION		DO NOT SCALE DRAWING					

5

4

3

2

1

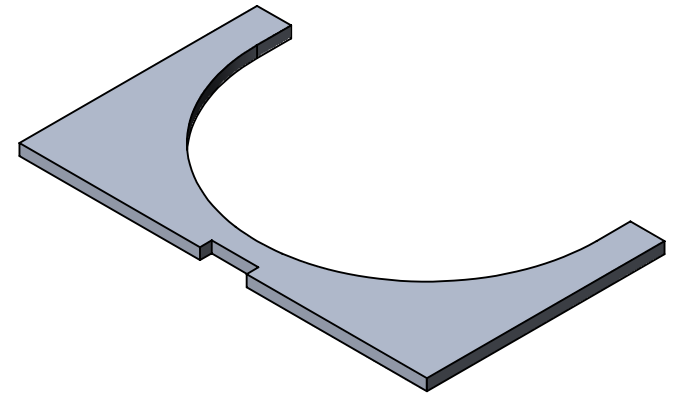
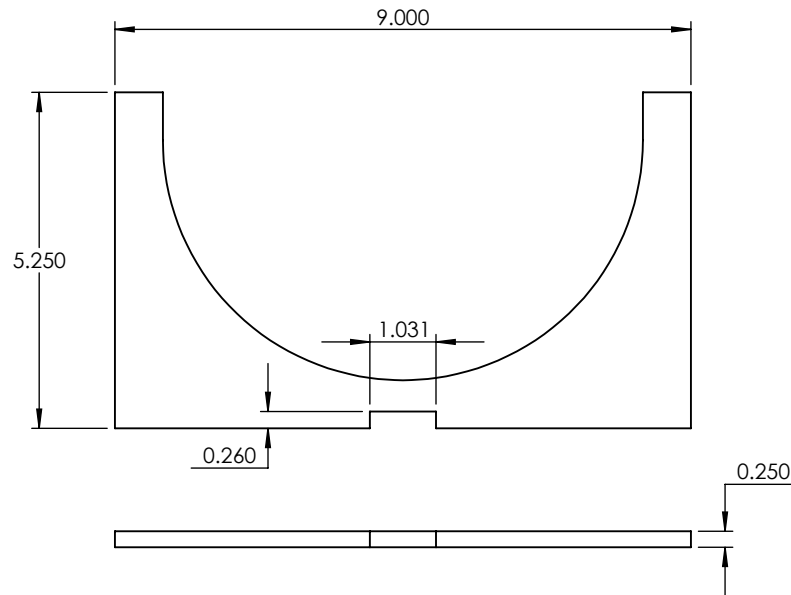
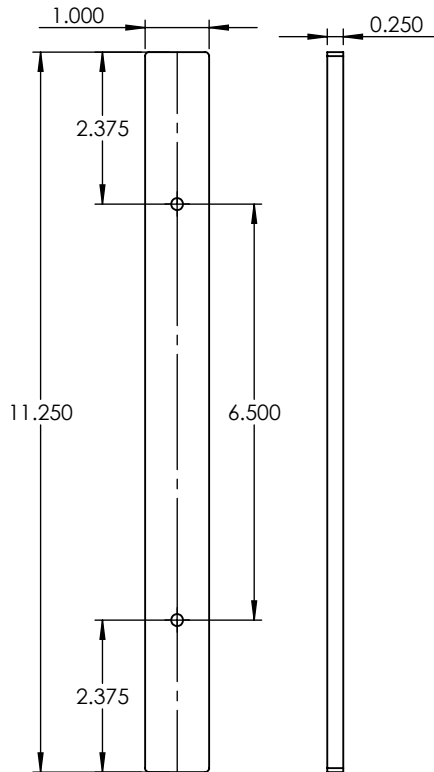

UNLESS OTHERWISE SPECIFIED:		NAME	DATE	ALUMINUM 0.250" PLATE		
DIMENSIONS ARE IN INCHES TOLERANCES: FRACTIONAL ± ANGULAR: MACH ± BEND ± TWO PLACE DECIMAL ± THREE PLACE DECIMAL ±		DRAWN				TITLE:
INTERPRET GEOMETRIC TOLERANCING PER:		CHECKED		WNWL-12W-MN-WF-STBL-WET-12"-DIM-27K		
		ENG APPR.				
MATERIAL		MFG APPR.		SIZE	DWG. NO.	REV
		Q.A.		A		
FINISH		COMMENTS:		SCALE: 1:3	WEIGHT:	SHEET 8 OF 8
DO NOT SCALE DRAWING						

PROPRIETARY AND CONFIDENTIAL
THE INFORMATION CONTAINED IN THIS DRAWING IS THE SOLE PROPERTY OF <INSERT COMPANY NAME HERE>. ANY REPRODUCTION IN PART OR AS A WHOLE WITHOUT THE WRITTEN PERMISSION OF <INSERT COMPANY NAME HERE> IS PROHIBITED.

NEXT ASSY	USED ON
APPLICATION	

5

4

3

2

1