

ITEM NO.	PART NUMBER	DESCRIPTION	QTY.	CUT
1	HFWLC2-8W-27"-AB-WF-ST-WET-30K-FRAME	22 GAUGE	1	
2	HFWLC2-8W-27"-AB-WF-ST-WET-30K-BACKPLATE	22 GAUGE	1	
3	HFWLC2-8W-27"-AB-WF-ST-WET-30K-FIREPLATE	22 GAUGE	1	
4	HFWLC2-8W-27"-AB-WF-ST-WET-30K-END UNDERCAP	22 GAUGE	1	
5	HFWLC2-8W-27"-AB-WF-ST-WET-30K-END CAP	22 GAUGE	1	
6	HFWLC2-8W-27"-AB-WF-ST-WET-30K-CAP STRAP	22 GAUGE	1	
7	HFWLC2-8W-27"-AB-WF-ST-WET-30K-CENTER STRAP	22 GAUGE	1	
8	HFWLC2-8W-27"-AB-WF-ST-WET-30K-BOTTOM STRAP	22 GAUGE	1	
9	HFWLC2-8W-27"-AB-WF-ST-WET-30K-ACRYLIC	ACRYLIC	1	
10	HFWLC2-8W-27"-AB-WF-ST-WET-30K-HORIZONTAL FLAT BAR	1/2"X1/4" ALUMINUM FLAT BAR	1	
11	HFWLC2-8W-27"-AB-WF-ST-WET-30K-ALUMINUM BAR	1/2" SQUARE ALUMINUM BAR	1	
12	Espen VEL19070MVH-1	DRIVER	1	
13	AltaILED PN105B-11-SS	LED	2	

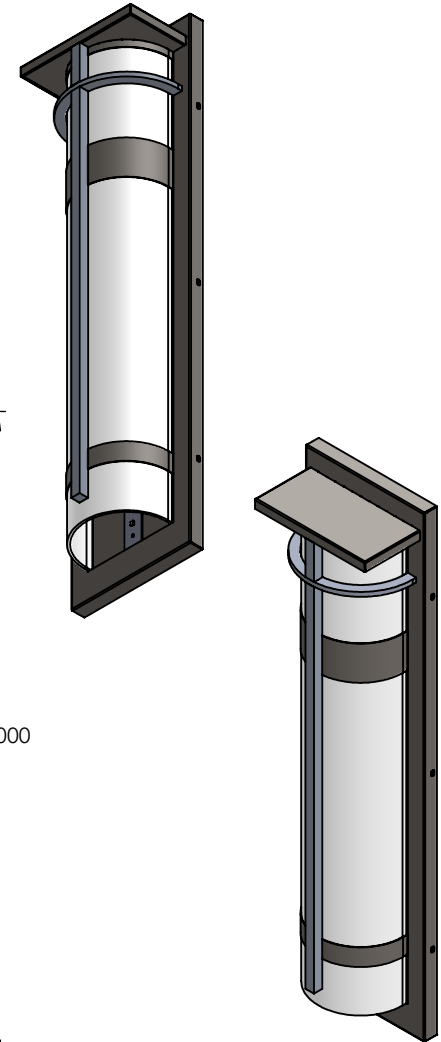
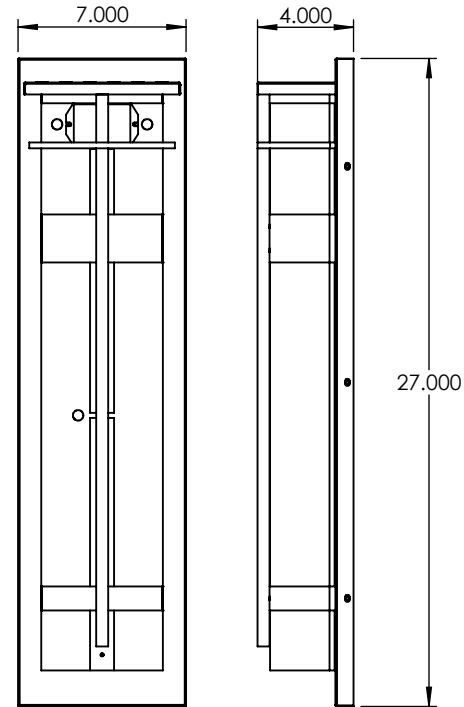
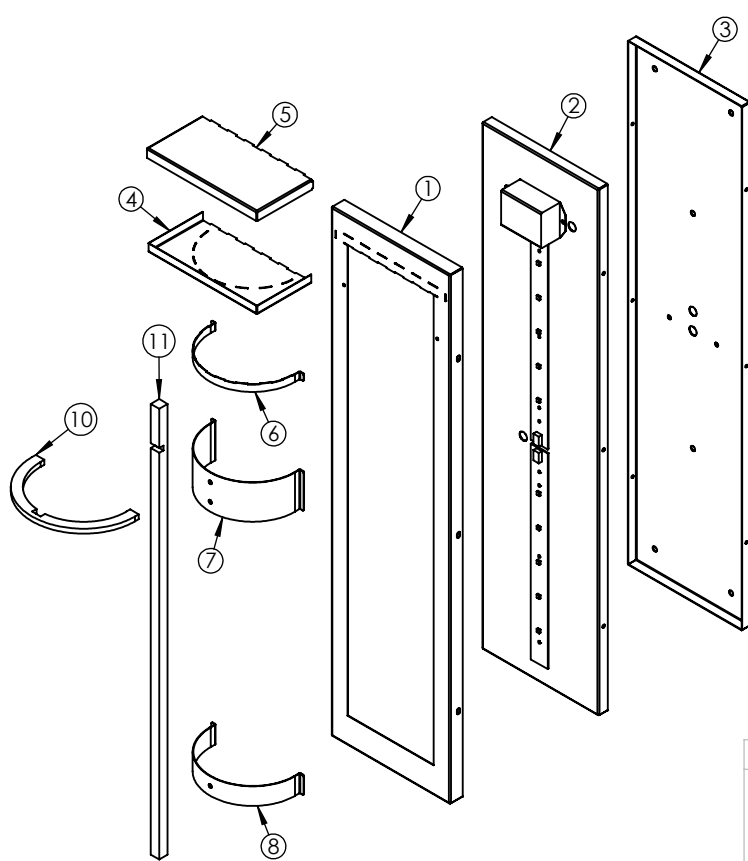

ALL BEND RADIUS .030"

APPLICATION

DO NOT SCALE DRAWING

UNLESS OTHERWISE SPECIFIED:

DIMENSIONS ARE IN INCHES  
 TOLERANCES:  
 FRACTIONAL ± .003  
 ANGULAR: MACH ± .01 BEND ±  
 TWO PLACE DECIMAL ±  
 THREE PLACE DECIMAL ±.001

INTERPRET GEOMETRIC  
 TOLERANCING PER:

MATERIAL

FINISH

NAME

DATE

DRAWN

CHECKED

ENG APPR.

MFG APPR.

Q.A.

COMMENTS:

TITLE:

HFWLC2-8W-27"-AB-WF-ST-WET-30K

SIZE DWG. NO.

**A** TICKET 27152

REV

SCALE: 1:8

WEIGHT:

SHEET 1 OF 9

5

4

3

2

1

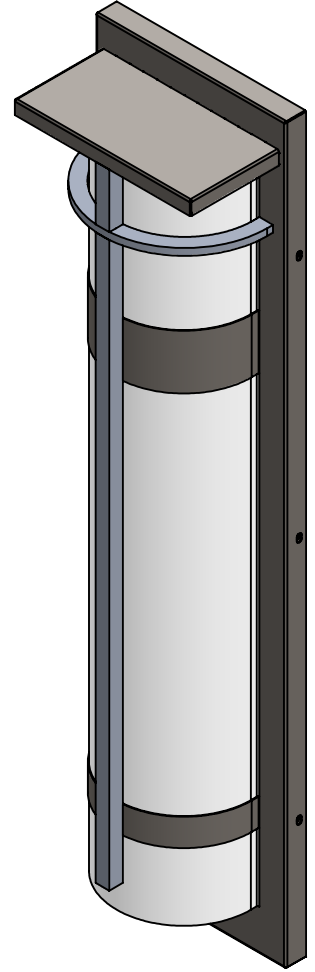
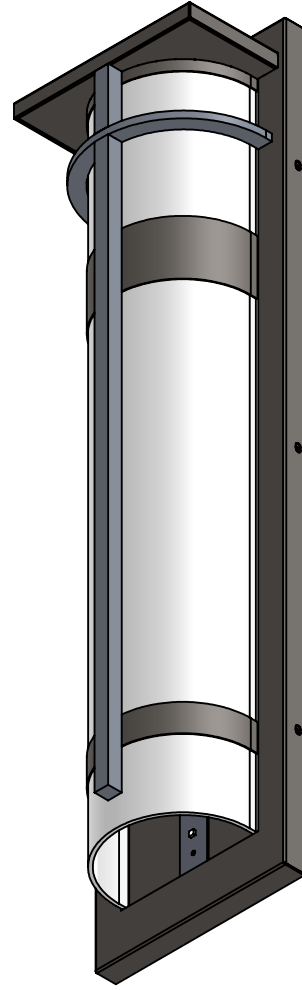
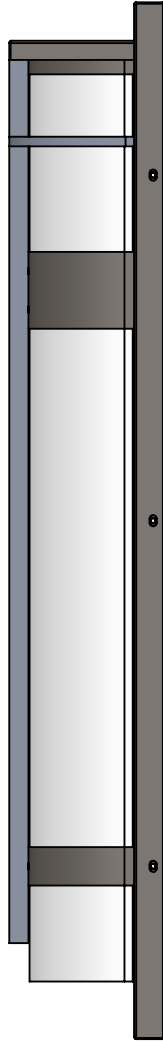
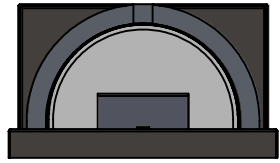
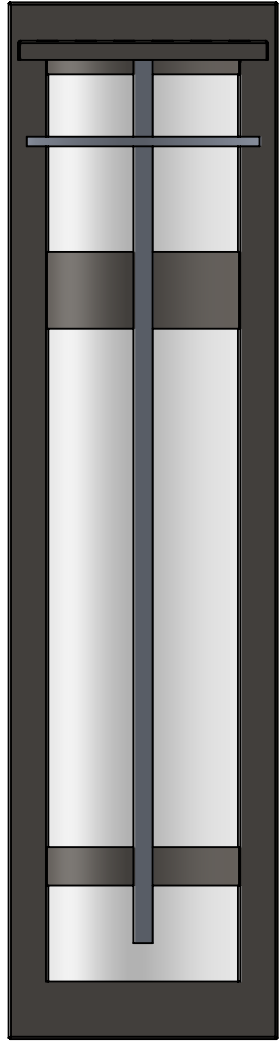

DETAIL A  
SCALE 1 : 1

STURDY WELDING TO SUPPORT WEIGHT

WELDING ALL AROUND  
WELD BACKSIDE AS WELL

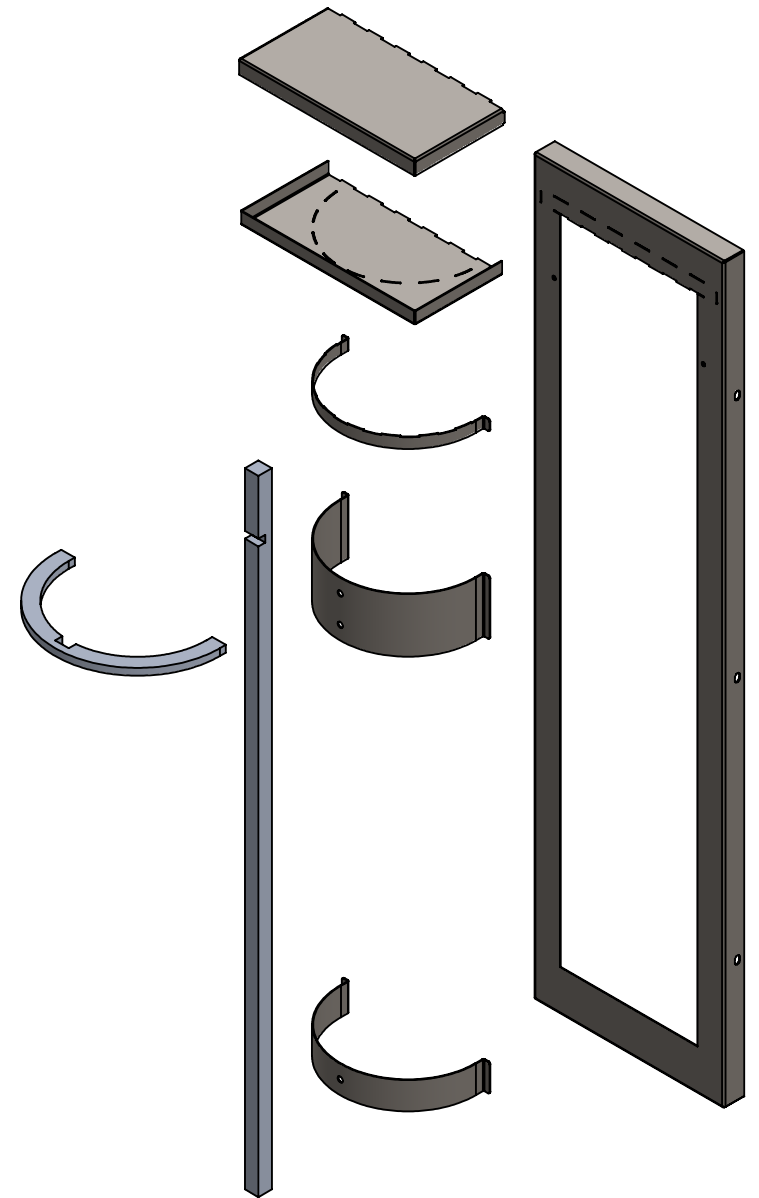
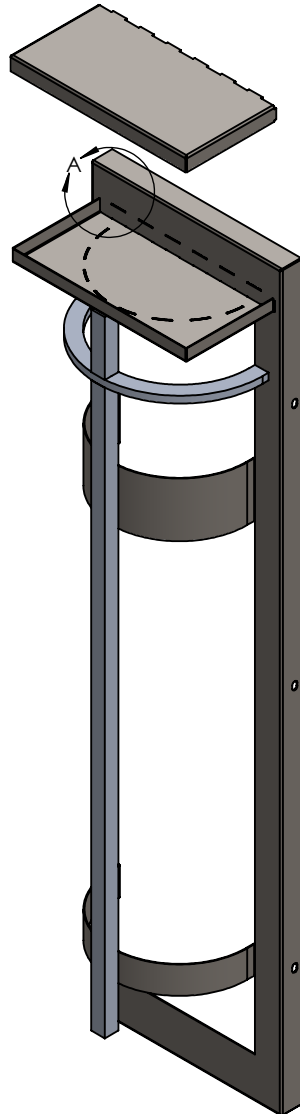
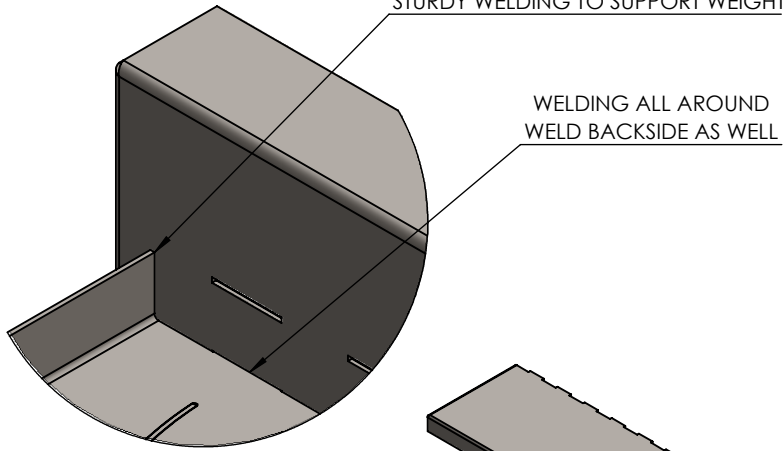
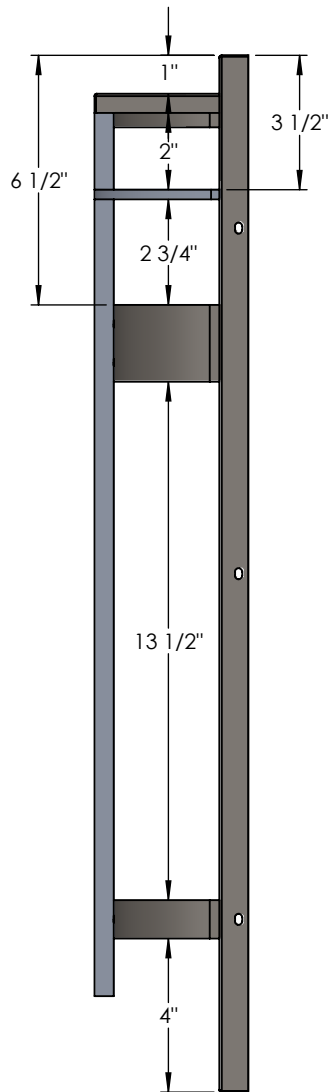

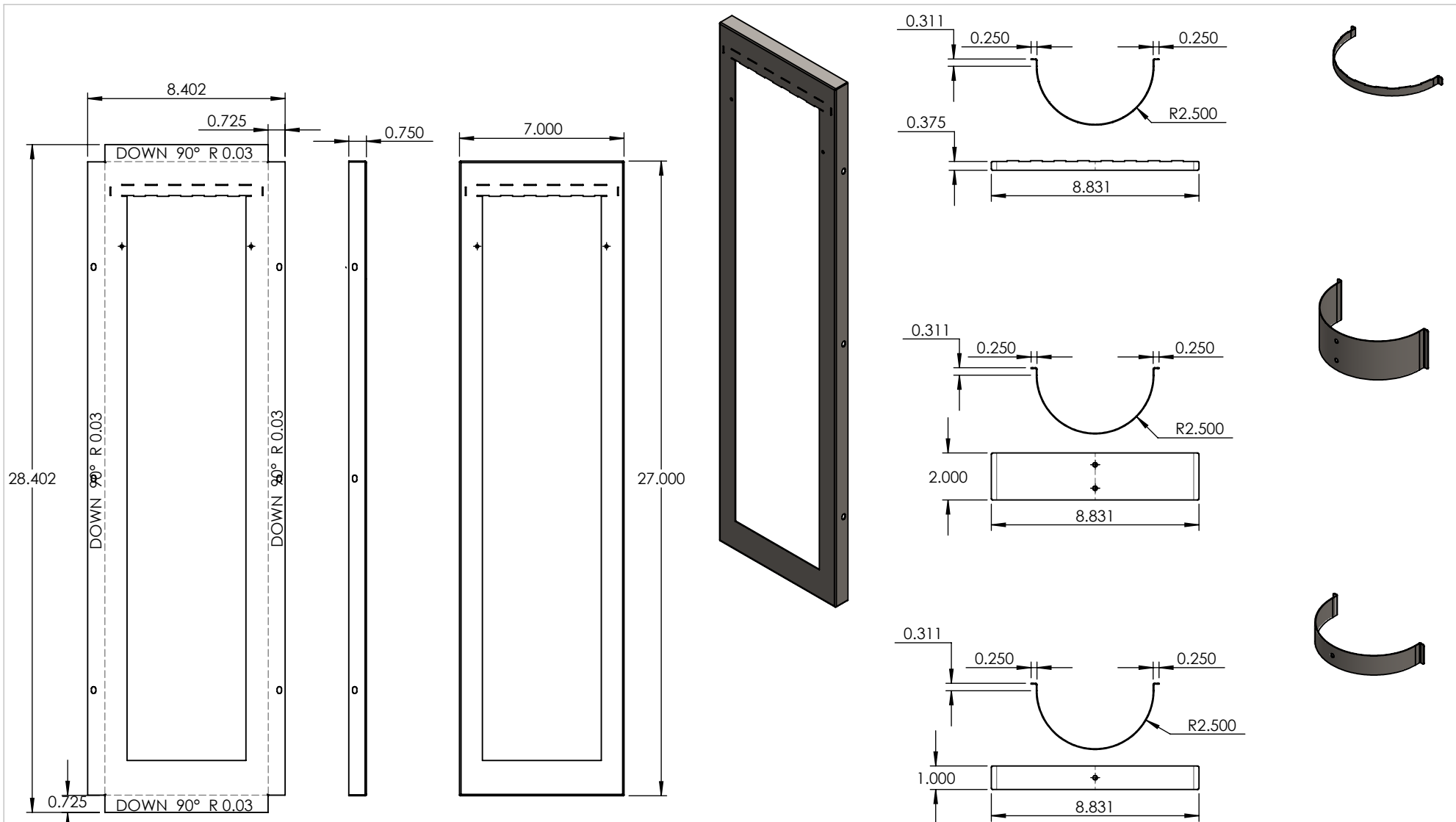

**PROPRIETARY AND CONFIDENTIAL**  
 THE INFORMATION CONTAINED IN THIS DRAWING IS THE SOLE PROPERTY OF <INSERT COMPANY NAME HERE>. ANY REPRODUCTION IN PART OR AS A WHOLE WITHOUT THE WRITTEN PERMISSION OF <INSERT COMPANY NAME HERE> IS PROHIBITED.

		UNLESS OTHERWISE SPECIFIED:	NAME	DATE
		DIMENSIONS ARE IN INCHES	DRAWN	
		TOLERANCES:	CHECKED	
		FRACTIONAL ±	ENG APPR.	
		ANGULAR: MACH ± BEND ±	MFG APPR.	
		TWO PLACE DECIMAL ±	Q.A.	
		THREE PLACE DECIMAL ±	COMMENTS:	
		INTERPRET GEOMETRIC TOLERANCING PER:		
		MATERIAL		
NEXT ASSY	USED ON	FINISH		
APPLICATION		DO NOT SCALE DRAWING		

<b>22 GAUGE</b>		
TITLE:		
HFWLC2-8W-27"-AB-WF-ST-WET-30K		
SIZE	DWG. NO.	REV
<b>A</b>		
SCALE: 1:6	WEIGHT:	SHEET 4 OF 9

5

4

3

2

1

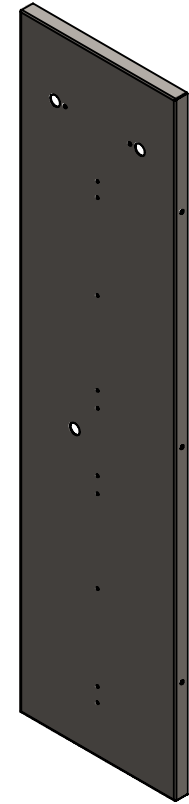
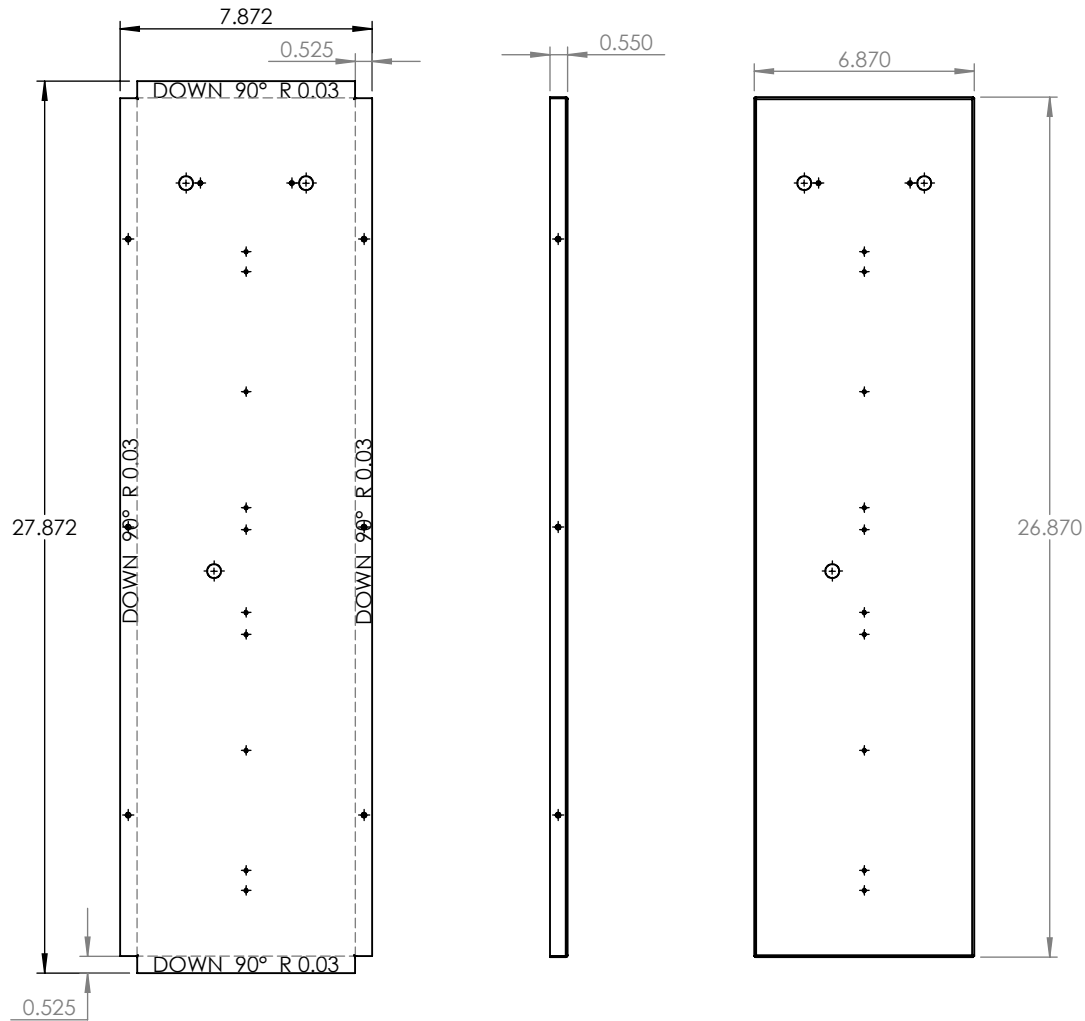

**PROPRIETARY AND CONFIDENTIAL**  
 THE INFORMATION CONTAINED IN THIS DRAWING IS THE SOLE PROPERTY OF <INSERT COMPANY NAME HERE>. ANY REPRODUCTION IN PART OR AS A WHOLE WITHOUT THE WRITTEN PERMISSION OF <INSERT COMPANY NAME HERE> IS PROHIBITED.

		UNLESS OTHERWISE SPECIFIED:		NAME	DATE
		DIMENSIONS ARE IN INCHES	DRAWN		
		TOLERANCES:	CHECKED		
		FRACTIONAL ±	ENG APPR.		
		ANGULAR: MACH ± BEND ±	MFG APPR.		
		TWO PLACE DECIMAL ±	Q.A.		
		THREE PLACE DECIMAL ±	COMMENTS:		
		INTERPRET GEOMETRIC TOLERANCING PER:			
		MATERIAL			
NEXT ASSY	USED ON	FINISH			
APPLICATION		DO NOT SCALE DRAWING			

<b>22 GAUGE</b>		
TITLE:		
HFWLC2-8W-27"-AB-WF-ST-WET-30K		
SIZE	DWG. NO.	REV
<b>A</b>		
SCALE: 1:6	WEIGHT:	SHEET 5 OF 9



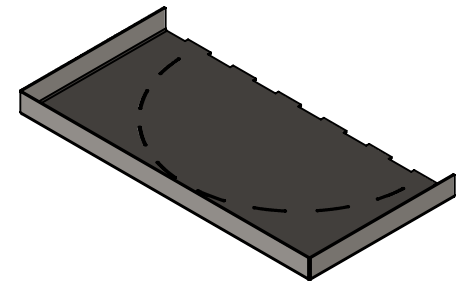
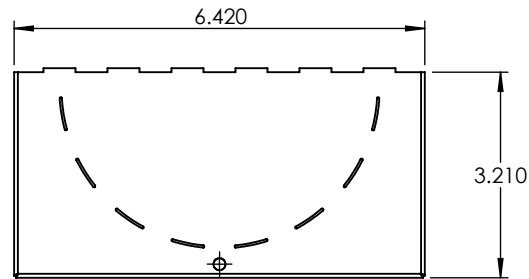
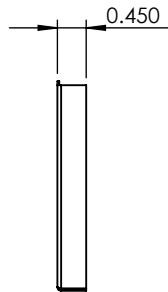
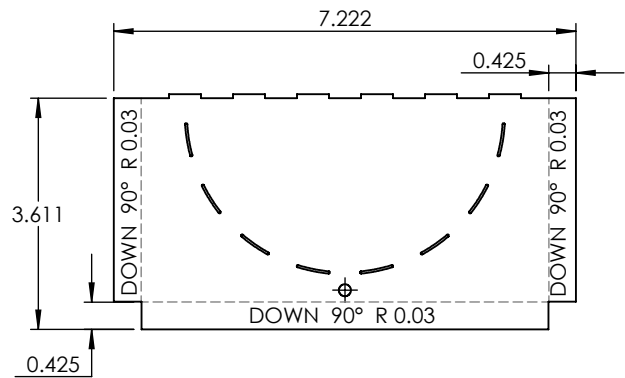
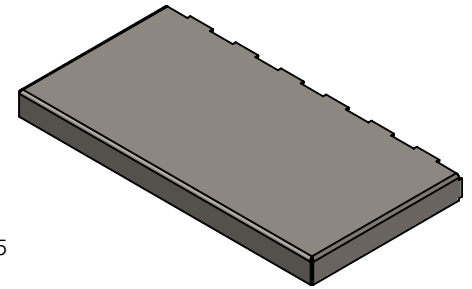
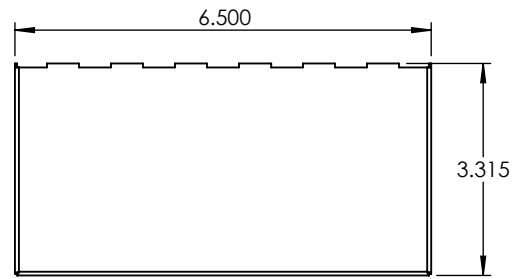
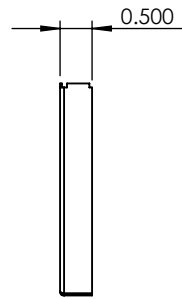
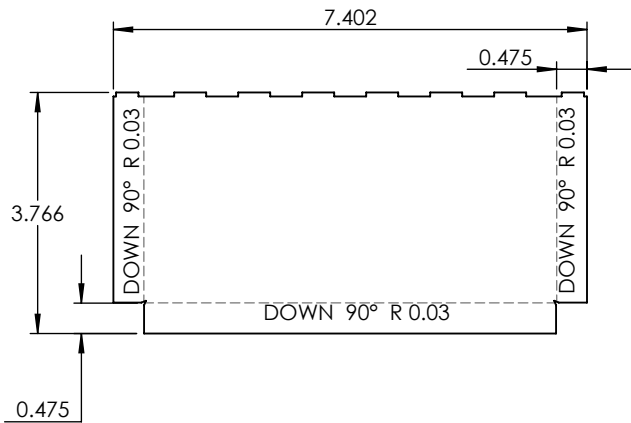

**PROPRIETARY AND CONFIDENTIAL**  
 THE INFORMATION CONTAINED IN THIS DRAWING IS THE SOLE PROPERTY OF <INSERT COMPANY NAME HERE>. ANY REPRODUCTION IN PART OR AS A WHOLE WITHOUT THE WRITTEN PERMISSION OF <INSERT COMPANY NAME HERE> IS PROHIBITED.

		UNLESS OTHERWISE SPECIFIED:		NAME	DATE
		DIMENSIONS ARE IN INCHES	DRAWN		
		TOLERANCES:	CHECKED		
		FRACTIONAL ±	ENG APPR.		
		ANGULAR: MACH ± BEND ±	MFG APPR.		
		TWO PLACE DECIMAL ±	Q.A.		
		THREE PLACE DECIMAL ±	COMMENTS:		
		INTERPRET GEOMETRIC TOLERANCING PER:			
		MATERIAL			
NEXT ASSY	USED ON	FINISH			
APPLICATION		DO NOT SCALE DRAWING			

<b>22 GAUGE</b>		
TITLE:		
<b>HFWLC2-8W-27"-AB-WF-ST-WET-30K</b>		
SIZE	DWG. NO.	REV
<b>A</b>		
SCALE: 1:3	WEIGHT:	SHEET 7 OF 9

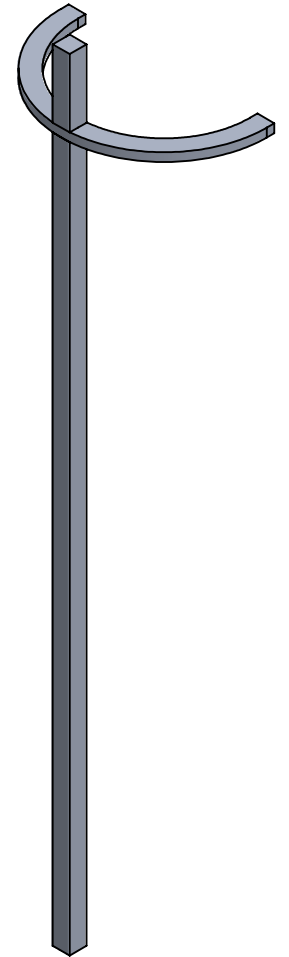
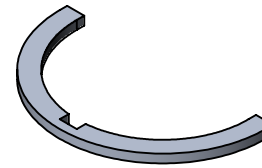
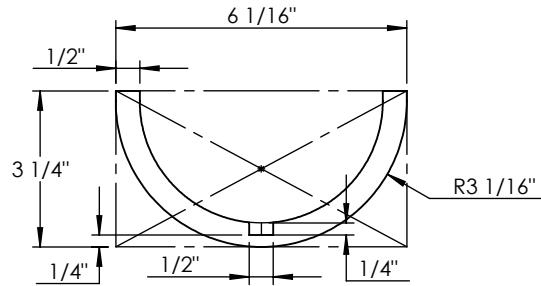
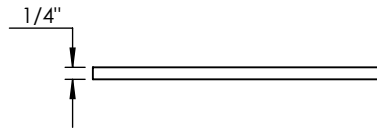
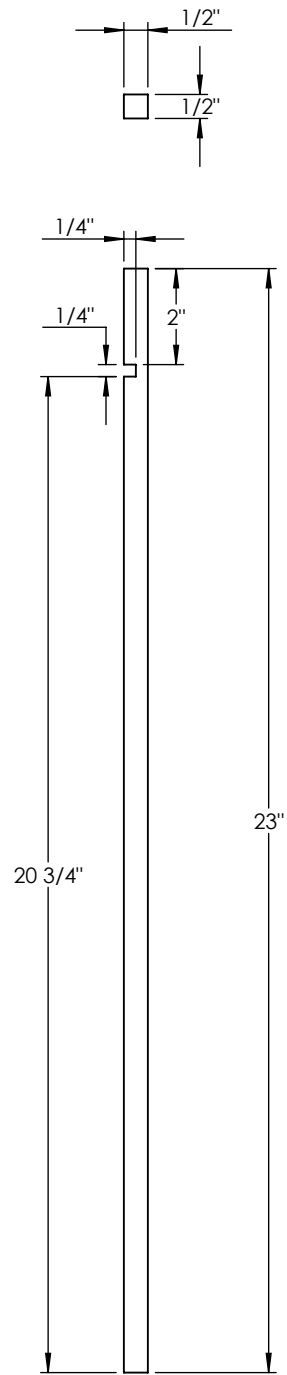

		UNLESS OTHERWISE SPECIFIED:	NAME	DATE	1/2" SQUARE ALUMINUM BAR	
		DIMENSIONS ARE IN INCHES	DRAWN		TITLE:	
		TOLERANCES:	CHECKED		HFWLC2-8W-27"-AB-WF-ST-WET-30K	
		FRACTIONAL ±	ENG APPR.		SIZE DWG. NO. REV	
		ANGULAR: MACH ± BEND ±	MFG APPR.		A	
		TWO PLACE DECIMAL ±	Q.A.		SCALE: 1:4 WEIGHT: SHEET 8 OF 9	
		THREE PLACE DECIMAL ±	COMMENTS:			
		INTERPRET GEOMETRIC TOLERANCING PER:				
		MATERIAL				
		FINISH				
NEXT ASSY	USED ON					
APPLICATION	DO NOT SCALE DRAWING					

5

4

3

2

1



