

ITEM NO.	PART NUMBER	DESCRIPTION	QTY.	CUT
1	LM-BOL8X3-40W-MBK-CA-40"-DIM-30K-ANCHOR PLATE	ALUMINUM 0.125" PLATE	1	
2	LM-BOL8X3-40W-MBK-CA-40"-DIM-30K-HEAD	ALUMINUM 0.125" PLATE	1	
3	LM-BOL8X3-40W-MBK-CA-40"-DIM-30K-HEAD-BOTTOM PLATE	ALUMINUM 0.125" PLATE	1	
4	LM-BOL8X3-40W-MBK-CA-40"-DIM-30K-LENS PLATE	ALUMINUM 0.125" PLATE	1	
5	LM-BOL8X3-40W-MBK-CA-40"-DIM-30K-VERTICAL REC TUBE BACK PLATE	ALUMINUM 0.125" PLATE	2	
6	LM-BOL8X3-40W-MBK-CA-40"-DIM-30K-VERTICAL REC TUBE SIDES PLATE	ALUMINUM 0.125" PLATE	2	
7	LM-BOL8X3-40W-MBK-CA-40"-DIM-30K-DOOR PLATE	ALUMINUM 0.125" PLATE	1	
8	LM-BOL8X3-40W-MBK-CA-40"-DIM-30K-DOOR BRACKET PLATE	ALUMINUM 0.0635"	1	
9	LM-BOL8X3-40W-MBK-CA-40"-DIM-30K-DRIVER BRACKET	ALUMINUM 0.0635"	1	
10	LM-BOL8X3-40W-MBK-CA-40"-DIM-30K-REGRESSED PLATE	ALUMINUM 0.0635"	1	
11	LM-BOL8X3-40W-MBK-CA-40"-DIM-30K-LED PLATE	ALUMINUM 0.0635"	1	
12	LM-BOL8X3-40W-MBK-CA-40"-DIM-30K-ACRYLIC	ACRYLIC	1	
14	Altiled PCN D2000-20W	LED	2	
15	HEXAGON HEAT SINK	HEAT SINK	2	
16	KTLD-25-UV-700-VDIM-LA1	DRIVER	2	

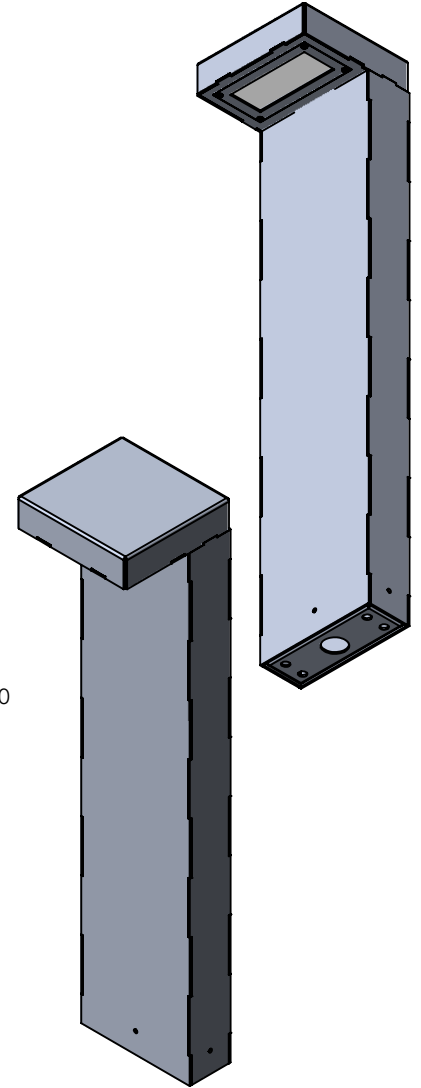
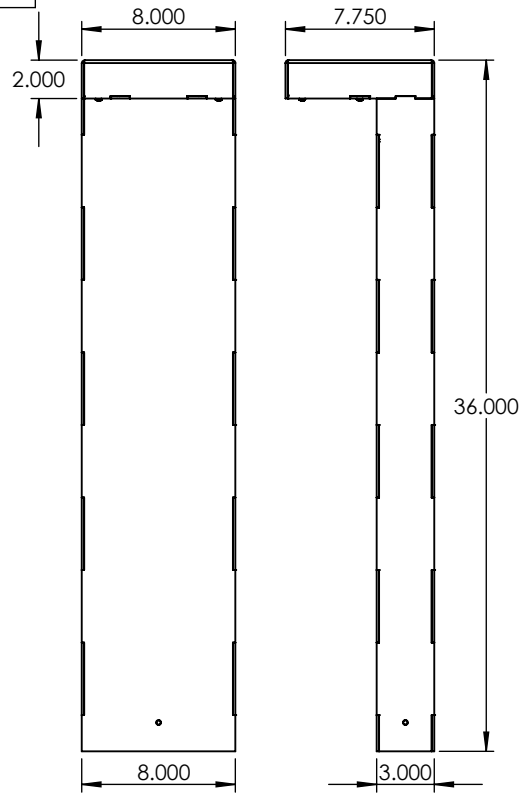
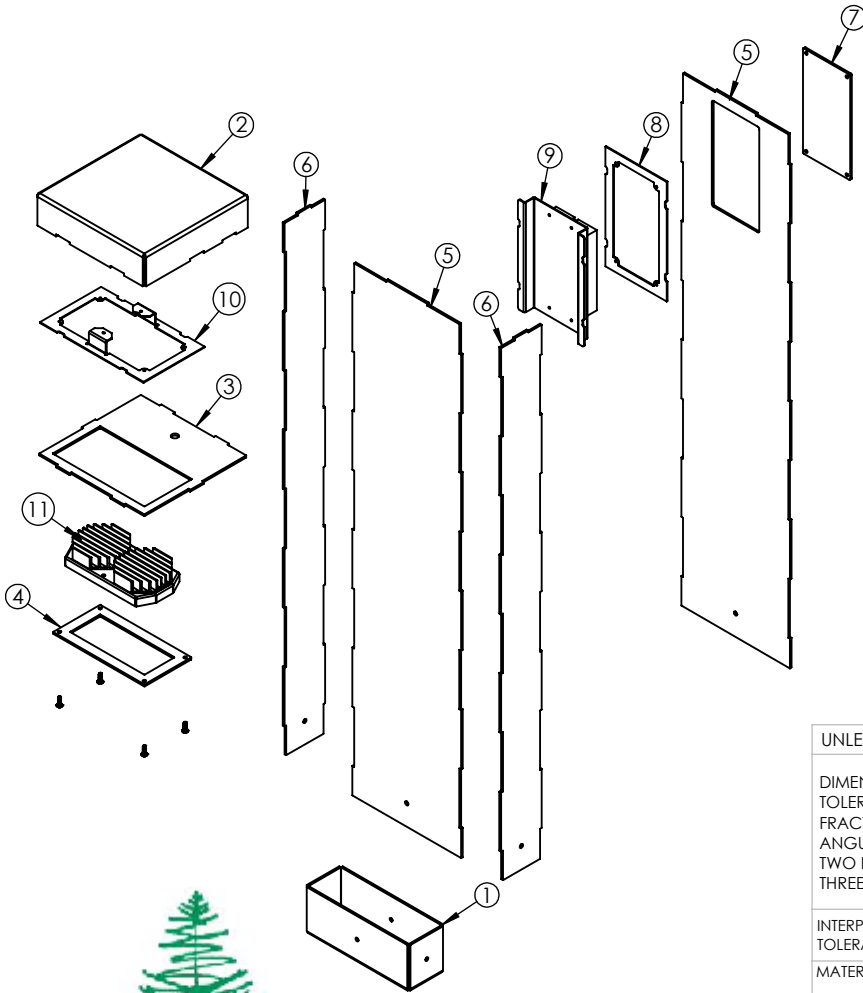

**EVERGREEN LIGHTING**

ALL BEND RADIUS .030"

APPLICATION

DO NOT SCALE DRAWING

UNLESS OTHERWISE SPECIFIED:

DIMENSIONS ARE IN INCHES  
 TOLERANCES:  
 FRACTIONAL ± .003  
 ANGULAR: MACH ± .01 BEND ±  
 TWO PLACE DECIMAL ±  
 THREE PLACE DECIMAL ±.001

INTERPRET GEOMETRIC  
 TOLERANCING PER:

MATERIAL

FINISH

NAME	DATE
DRAWN	
CHECKED	
ENG APPR.	
MFG APPR.	

TITLE:

LM-BOL8X3-40W-MBK-CA-40"-DIM-30K

SIZE DWG. NO.

REV

**A** TICKET 27216

SCALE: 1:10 WEIGHT:

SHEET 1 OF 9

5

4

3

2

1

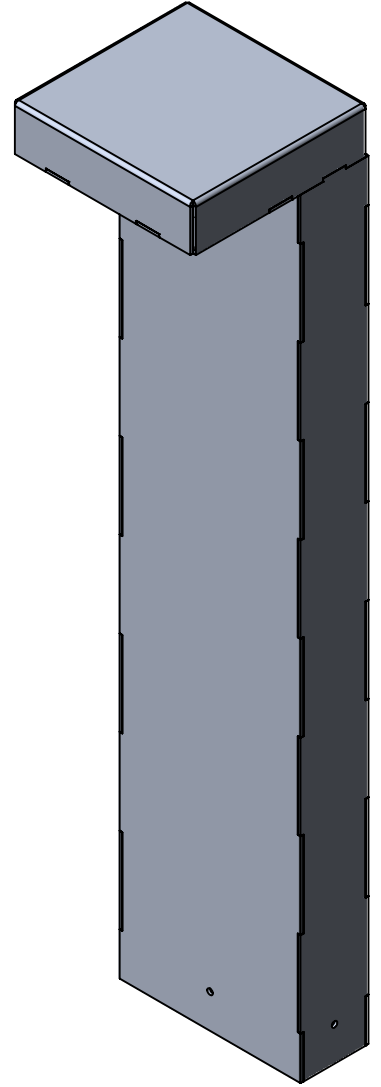
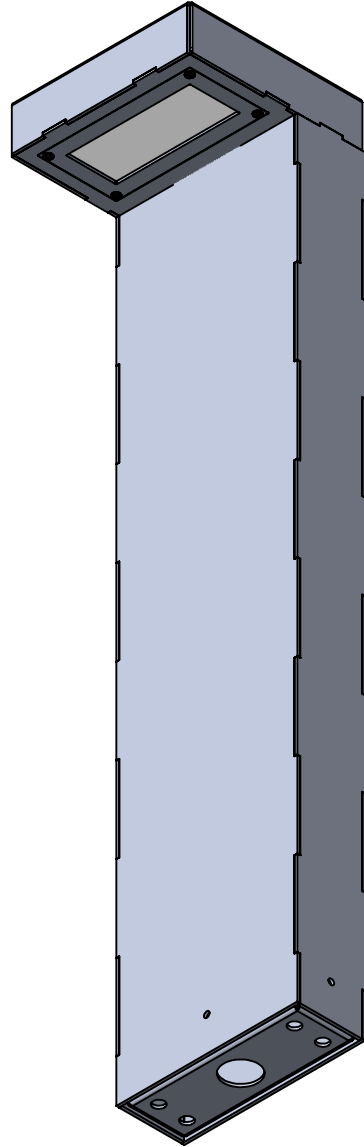
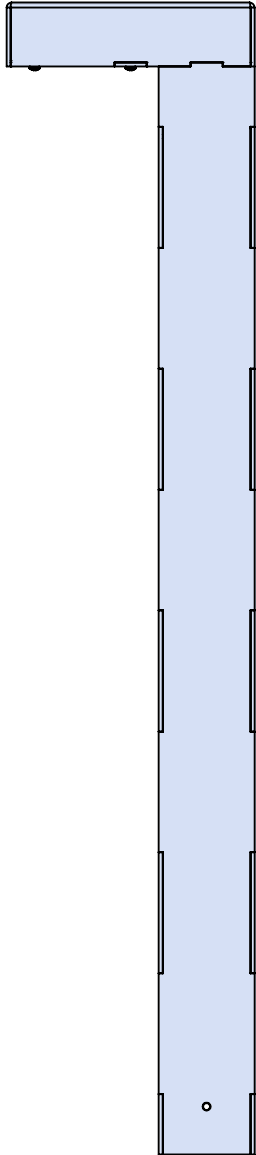
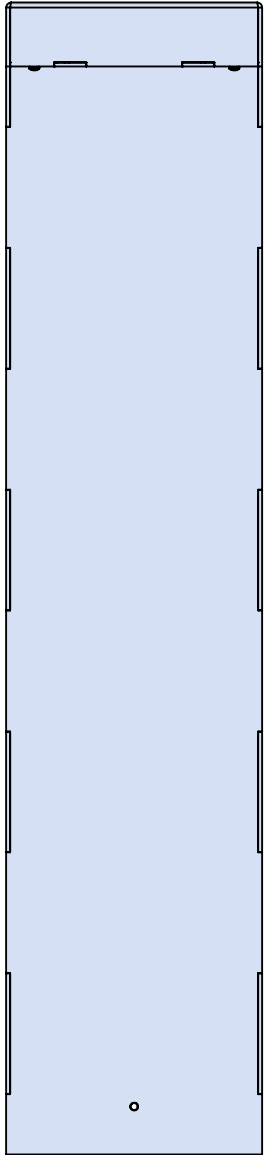

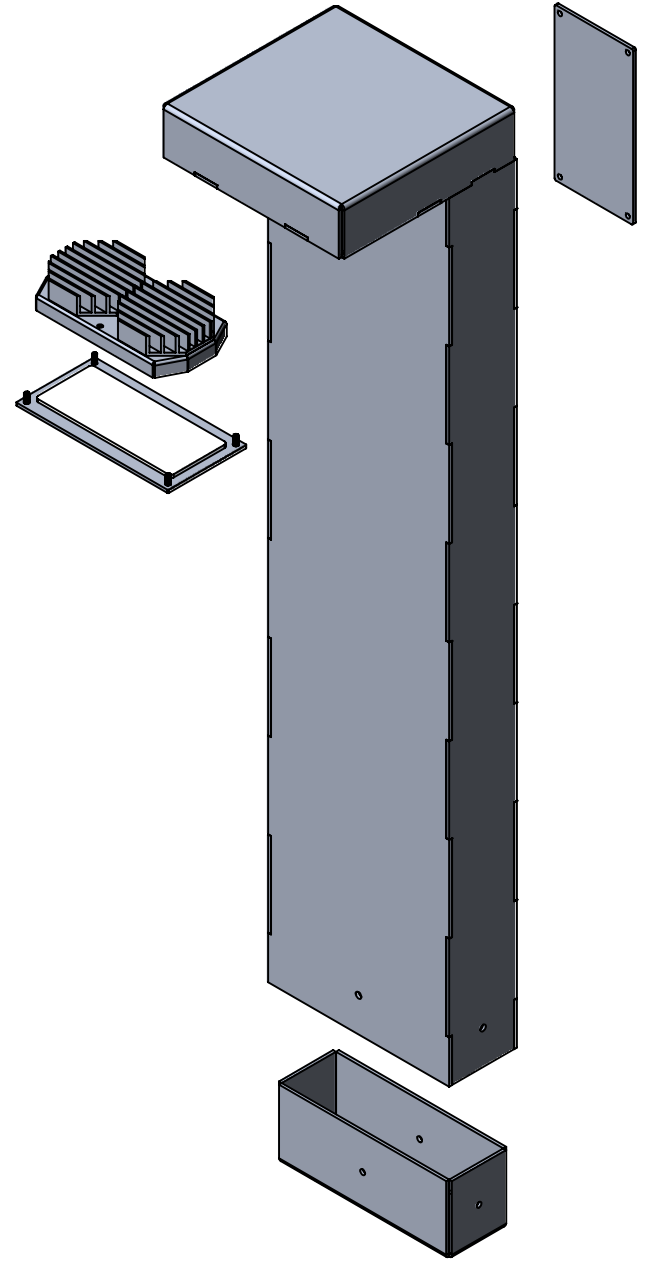
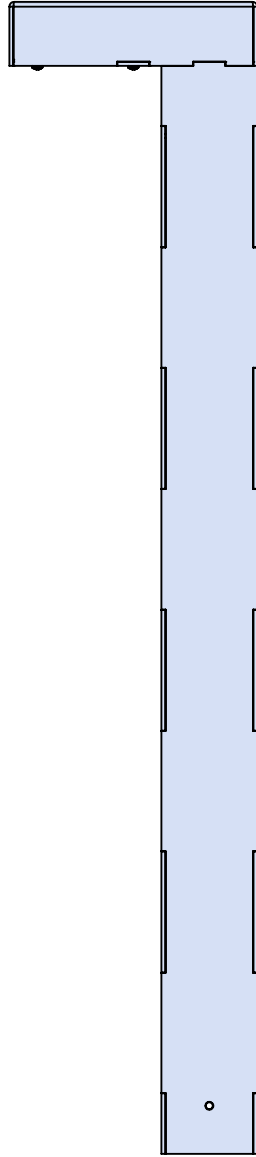
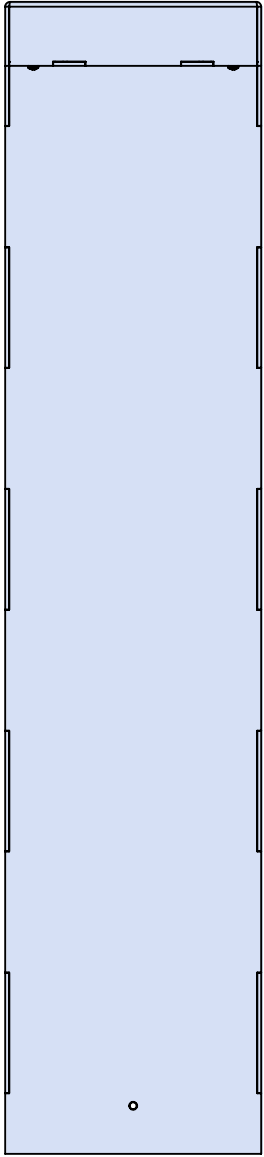

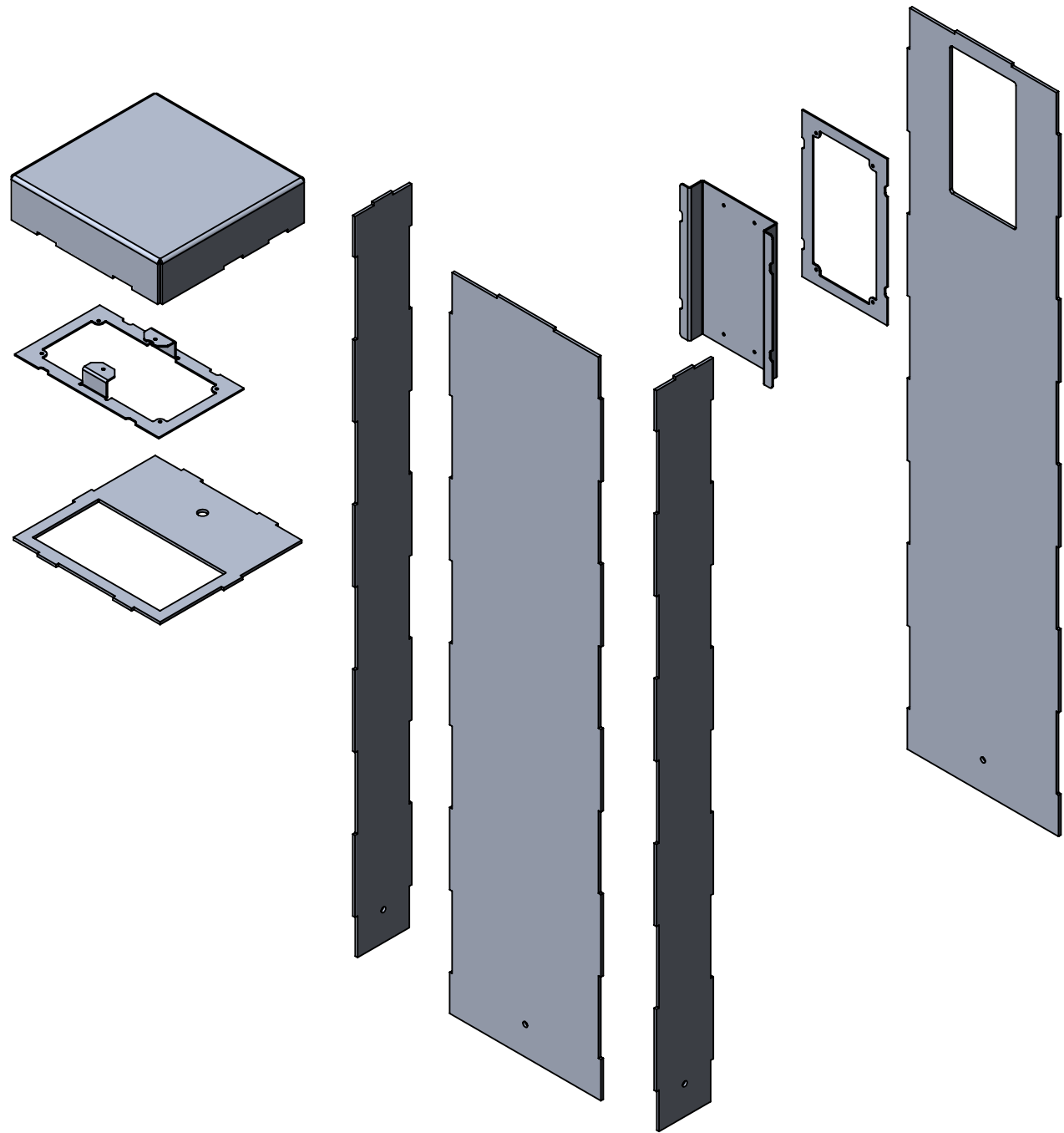

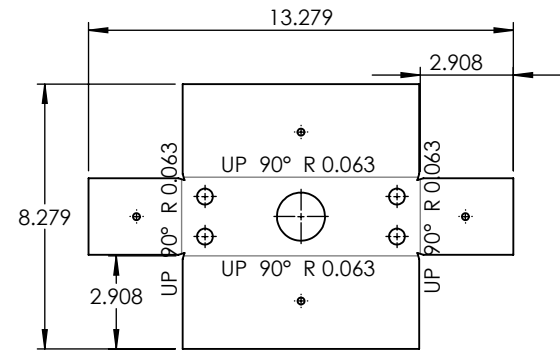
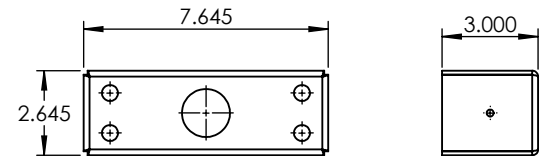
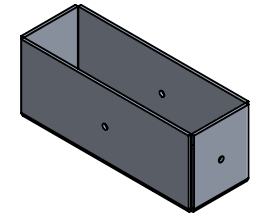
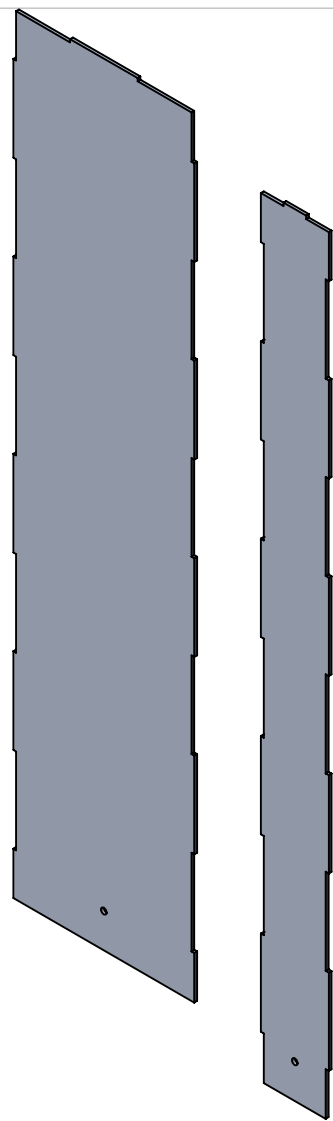
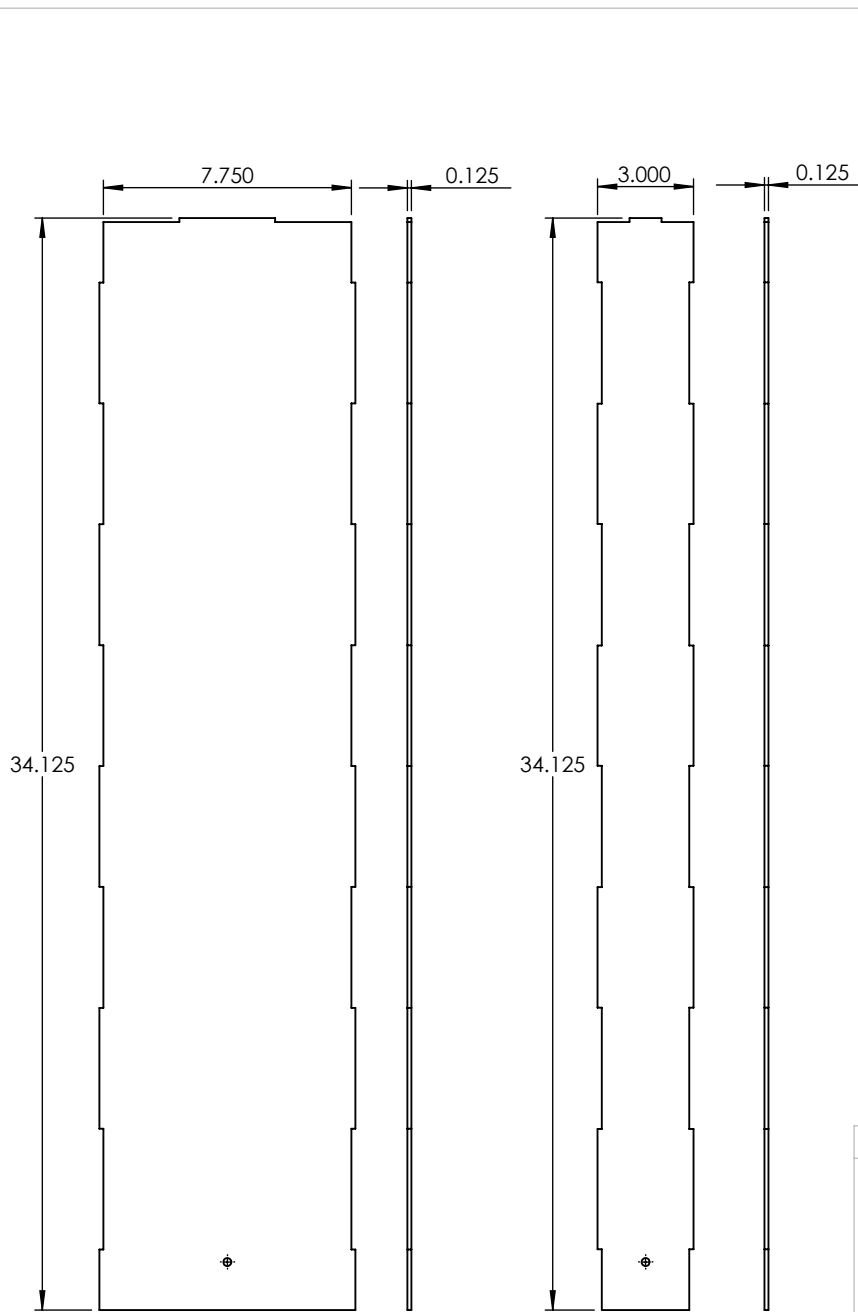

UNLESS OTHERWISE SPECIFIED:	NAME	DATE
DIMENSIONS ARE IN INCHES	DRAWN	
TOLERANCES:	CHECKED	
FRACTIONAL ±	ENG APPR.	
ANGULAR: MACH ± BEND ±	MFG APPR.	
TWO PLACE DECIMAL ±	Q.A.	
THREE PLACE DECIMAL ±	COMMENTS:	
INTERPRET GEOMETRIC TOLERANCING PER:		
MATERIAL		
FINISH		
APPLICATION		
DO NOT SCALE DRAWING		

8" x 4" ALUMINUM TUBE 1/4" WALL THICKNESS

TITLE:  
LM-BOL8X3-40W-MBK-CA-40"-DIM-30K

**PROPRIETARY AND CONFIDENTIAL**  
THE INFORMATION CONTAINED IN THIS DRAWING IS THE SOLE PROPERTY OF <INSERT COMPANY NAME HERE>. ANY REPRODUCTION IN PART OR AS A WHOLE WITHOUT THE WRITTEN PERMISSION OF <INSERT COMPANY NAME HERE> IS PROHIBITED.

NEXT ASSY	USED ON
APPLICATION	

SIZE	DWG. NO.	REV
<b>A</b>		
SCALE: 1:6	WEIGHT:	SHEET 5 OF 9

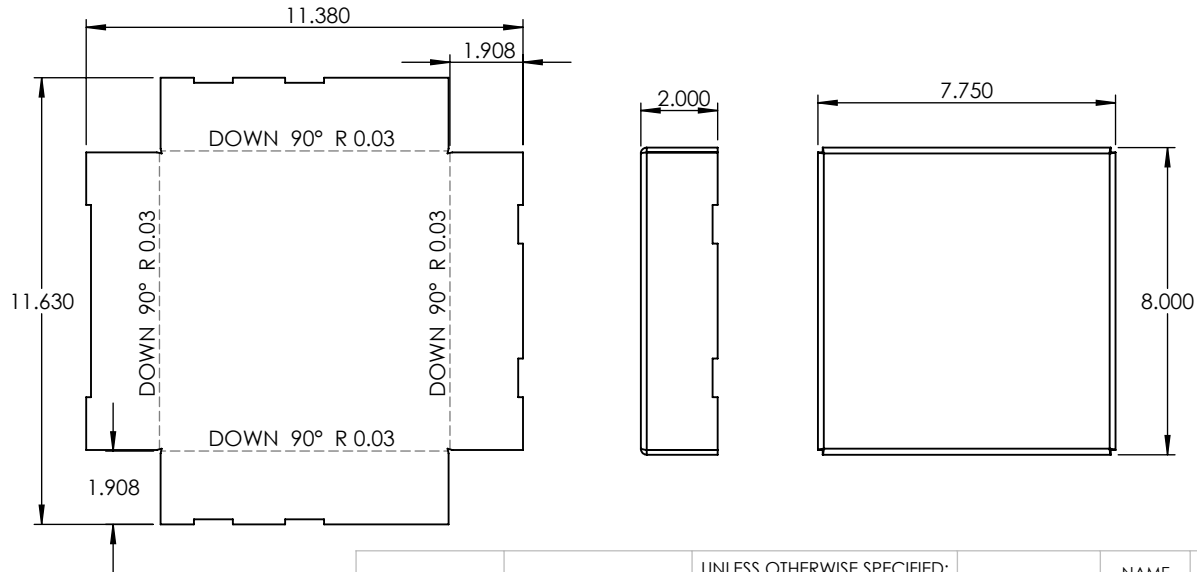
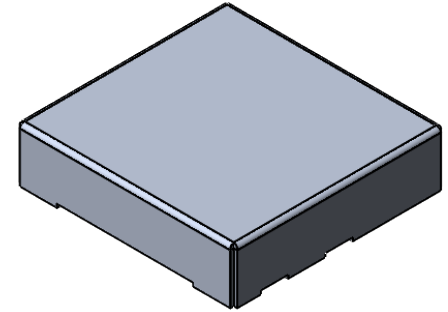
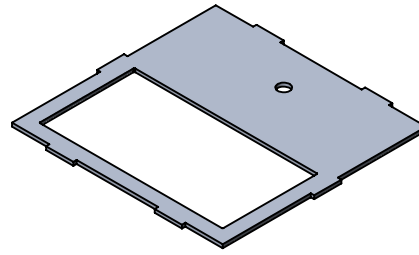
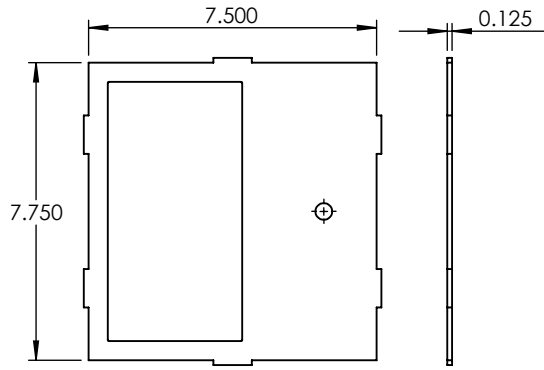

**PROPRIETARY AND CONFIDENTIAL**  
 THE INFORMATION CONTAINED IN THIS DRAWING IS THE SOLE PROPERTY OF <INSERT COMPANY NAME HERE>. ANY REPRODUCTION IN PART OR AS A WHOLE WITHOUT THE WRITTEN PERMISSION OF <INSERT COMPANY NAME HERE> IS PROHIBITED.

		UNLESS OTHERWISE SPECIFIED:		NAME	DATE
		DIMENSIONS ARE IN INCHES	DRAWN		
		TOLERANCES:	CHECKED		
		FRACTIONAL ±	ENG APPR.		
		ANGULAR: MACH ± BEND ±	MFG APPR.		
		TWO PLACE DECIMAL ±	Q.A.		
		THREE PLACE DECIMAL ±	COMMENTS:		
		INTERPRET GEOMETRIC TOLERANCING PER:			
		MATERIAL			
		FINISH			
NEXT ASSY	USED ON				
APPLICATION	DO NOT SCALE DRAWING				

ALUMINUM 0.125" PLATE

TITLE:  
 LM-BOL8X3-40W-MBK-CA-40"-DIM-30K

SIZE	DWG. NO.	REV
<b>A</b>		
SCALE: 1:5	WEIGHT:	SHEET 6 OF 9

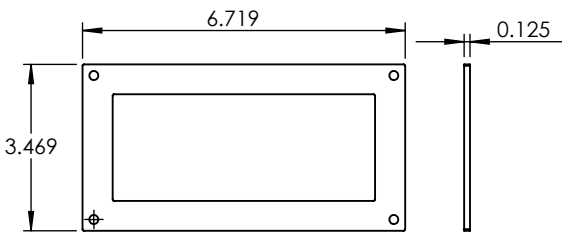
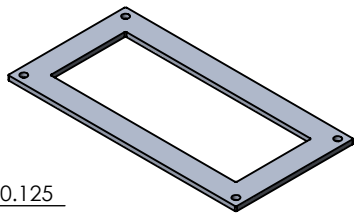
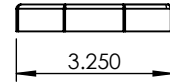
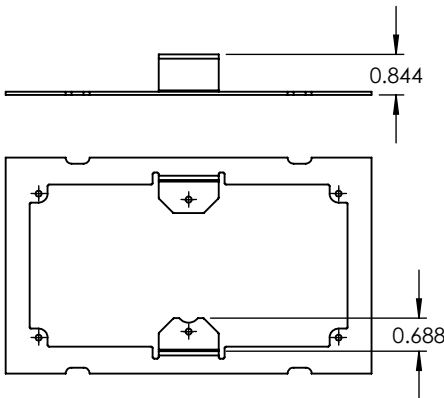
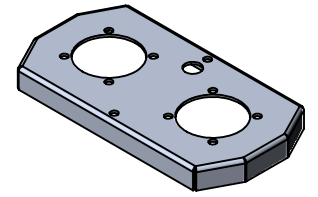
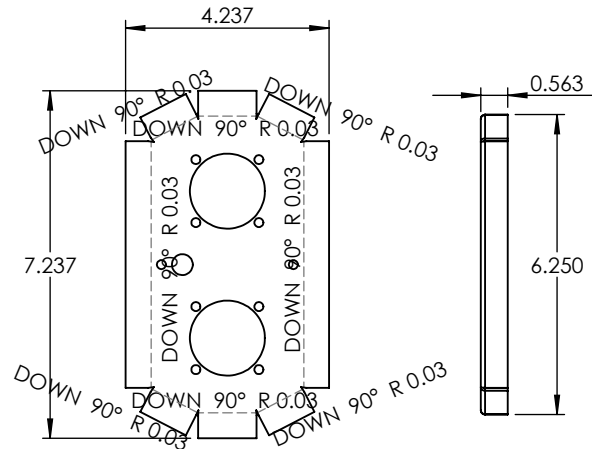
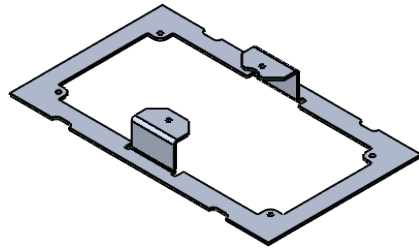
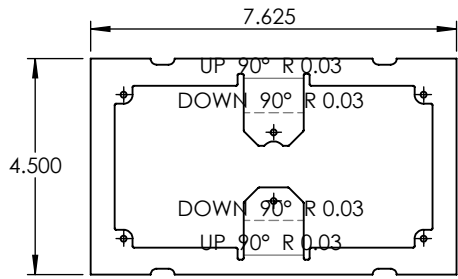

UNLESS OTHERWISE SPECIFIED:		NAME	DATE	ALUMINUM 0.0635"	
DIMENSIONS ARE IN INCHES		DRAWN		TITLE:	
TOLERANCES:		CHECKED		LM-BOL8X3-40W-MBK-CA-40"-DIM-30K	
FRACTIONAL ±		ENG APPR.		SIZE DWG. NO. REV	
ANGULAR: MACH ± BEND ±		MFG APPR.		A	
TWO PLACE DECIMAL ±		Q.A.		SCALE: 1:4 WEIGHT: SHEET 7 OF 9	
THREE PLACE DECIMAL ±		COMMENTS:			
INTERPRET GEOMETRIC TOLERANCING PER:					
MATERIAL					
FINISH					
NEXT ASSY	USED ON				
APPLICATION					
DO NOT SCALE DRAWING					

**PROPRIETARY AND CONFIDENTIAL**  
 THE INFORMATION CONTAINED IN THIS DRAWING IS THE SOLE PROPERTY OF <INSERT COMPANY NAME HERE>. ANY REPRODUCTION IN PART OR AS A WHOLE WITHOUT THE WRITTEN PERMISSION OF <INSERT COMPANY NAME HERE> IS PROHIBITED.

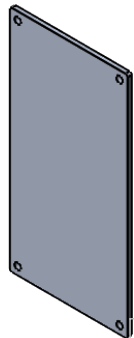
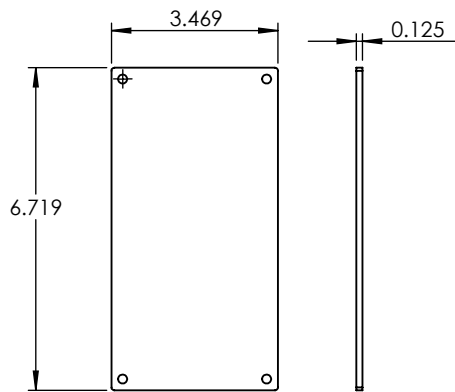
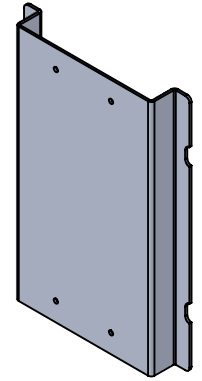
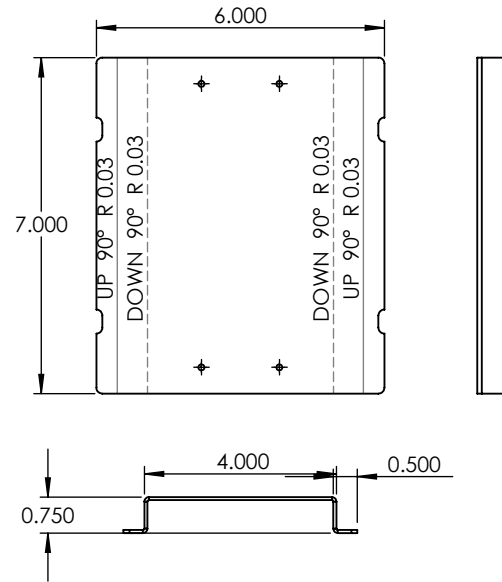
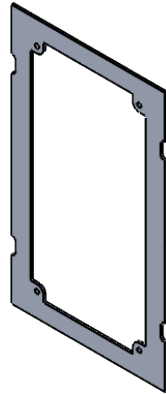
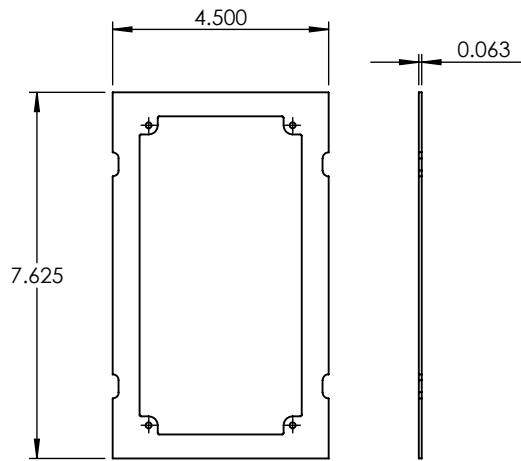

UNLESS OTHERWISE SPECIFIED:

DIMENSIONS ARE IN INCHES  
 TOLERANCES:  
 FRACTIONAL ±  
 ANGULAR: MACH ± BEND ±  
 TWO PLACE DECIMAL ±  
 THREE PLACE DECIMAL ±

INTERPRET GEOMETRIC  
 TOLERANCING PER:

MATERIAL

FINISH

DO NOT SCALE DRAWING

NAME DATE

DRAWN  
 CHECKED  
 ENG APPR.  
 MFG APPR.

Q.A.  
 COMMENTS:

ALUMINUM 0.0635"

TITLE:  
 LM-BOL8X3-40W-MBK-CA-40"-DIM-30K

**PROPRIETARY AND CONFIDENTIAL**  
 THE INFORMATION CONTAINED IN THIS  
 DRAWING IS THE SOLE PROPERTY OF  
 <INSERT COMPANY NAME HERE>. ANY  
 REPRODUCTION IN PART OR AS A WHOLE  
 WITHOUT THE WRITTEN PERMISSION OF  
 <INSERT COMPANY NAME HERE> IS  
 PROHIBITED.

NEXT ASSY	USED ON
APPLICATION	

SIZE <b>A</b>	DWG. NO.	REV
SCALE: 1:4	WEIGHT:	SHEET 8 OF 9



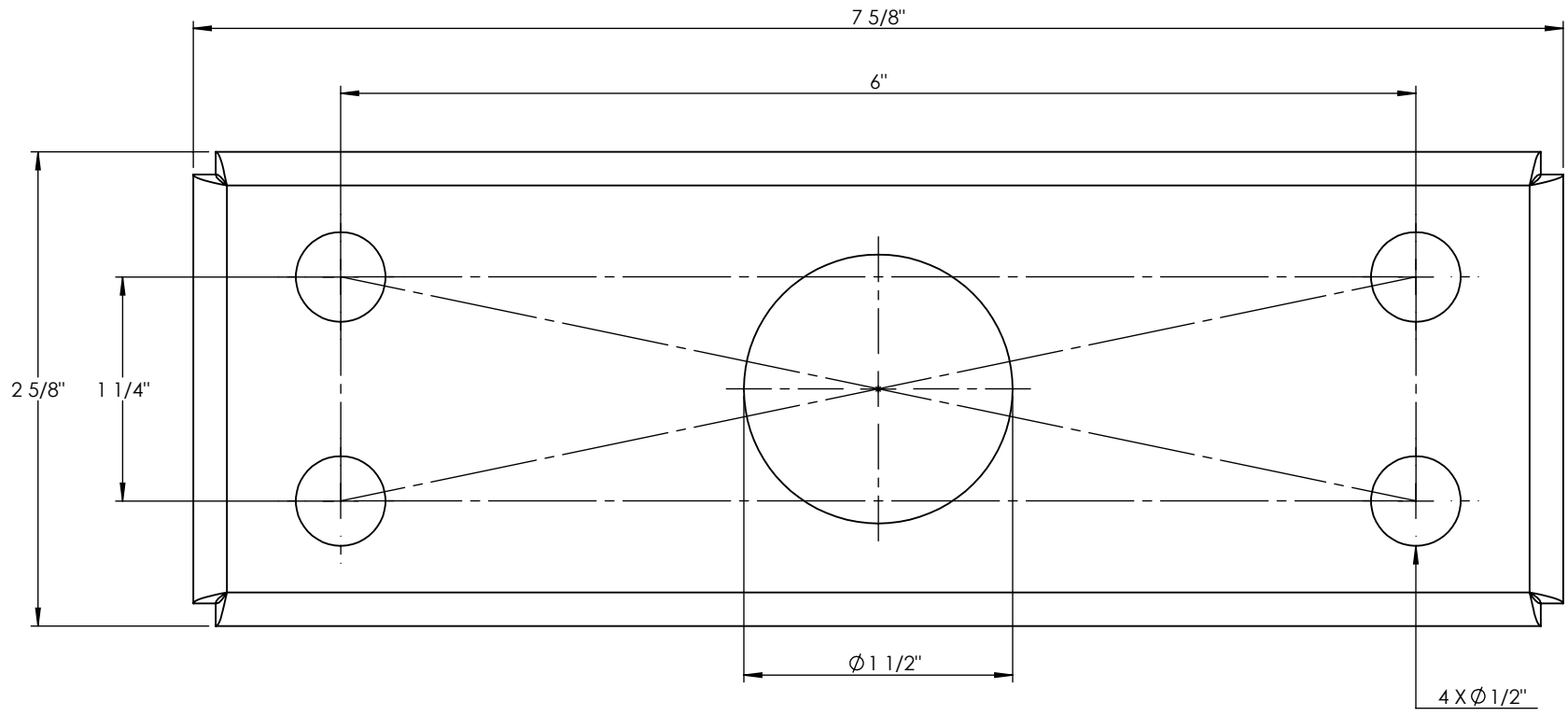

**3/16" X 12" LONG  
ANCHOR BOLT SIZE**