

ITEM NO.	PART NUMBER	DESCRIPTION	QTY.	CUT
1	CYL-VBB-30W-MBK-WF-DIM-46"-30K-SPUN CUP	SPUN ALUMINUM 0.080"	2	
2	CYL-VBB-30W-MBK-WF-DIM-46"-30K-BACKPLATE	22 GAUGE	1	
3	CYL-VBB-30W-MBK-WF-DIM-46"-30K-BACKPLATE TAB	22 GAUGE	4	
4	CYL-VBB-30W-MBK-WF-DIM-46"-30K-DRIVER BRACKET	22 GAUGE	1	
5	CYL-VBB-30W-MBK-WF-DIM-46"-30K-FIREPLATE	22 GAUGE	1	
6	CYL-VBB-30W-MBK-WF-DIM-46"-30K-LENS OUTERPLATE	22 GAUGE	1	
7	CYL-VBB-30W-MBK-WF-DIM-46"-30K-LED BRACKET	22 GAUGE	1	
8	CYL-VBB-30W-MBK-WF-DIM-46"-30K-OUTERPLATE COVER	22 GAUGE	1	
9	CYL-VBB-30W-MBK-WF-DIM-46"-30K-LENS INNERPLATE	22 GAUGE	1	
10	CYL-VBB-30W-MBK-WF-DIM-46"-30K-ACRYLIC	ACRYLIC	1	
11	Altiled_PN1010_RevD	LED	6	
12	DS-15W-350C1542010-3001	DRIVER	3	

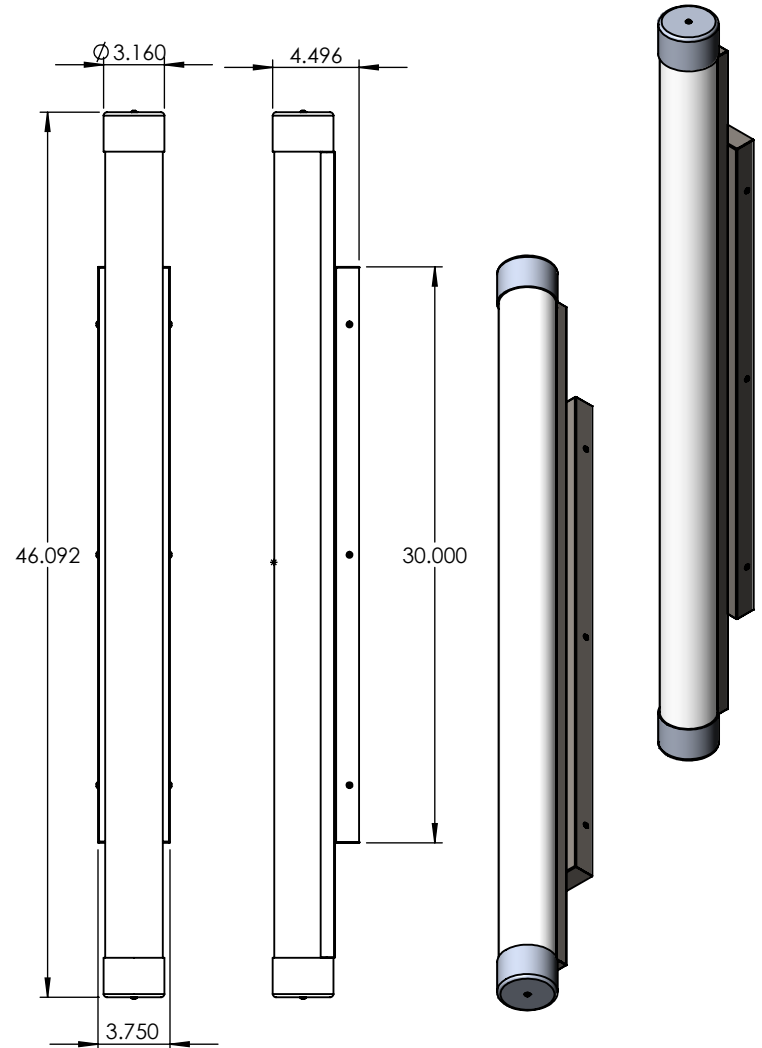
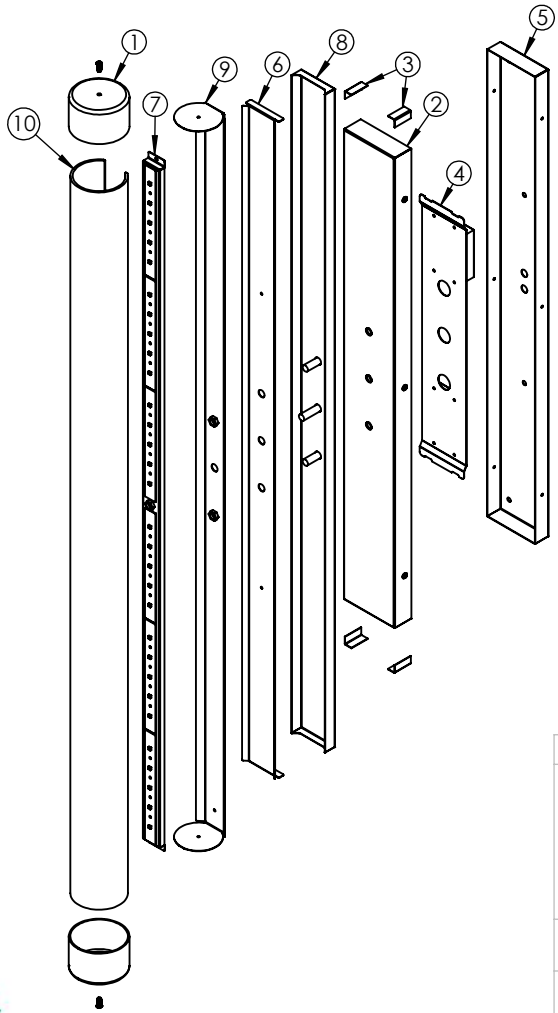

ALL BEND RADIUS .030"

APPLICATION

DO NOT SCALE DRAWING

UNLESS OTHERWISE SPECIFIED:

DIMENSIONS ARE IN INCHES
 TOLERANCES:
 FRACTIONAL ± .003
 ANGULAR: MACH ± .01 BEND ±
 TWO PLACE DECIMAL ±
 THREE PLACE DECIMAL ±.001

INTERPRET GEOMETRIC
 TOLERANCING PER:

MATERIAL

FINISH

NAME	DATE

DRAWN	
CHECKED	
ENG APPR.	
MFG APPR.	

Q.A.

COMMENTS:

TITLE:

CYL-VBB-30W-MBK-WF-DIM-46"-30K

SIZE	DWG. NO.	REV
A	TICKET 27219	

SCALE: 1:10 WEIGHT:

SHEET 1 OF 11

5

4

3

2

1

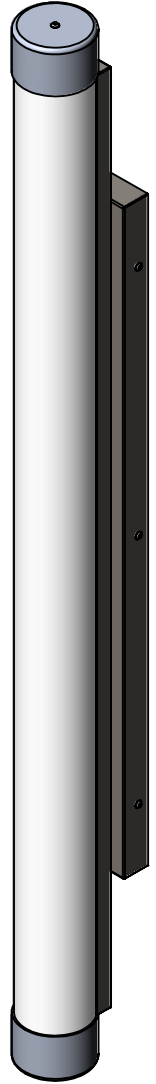
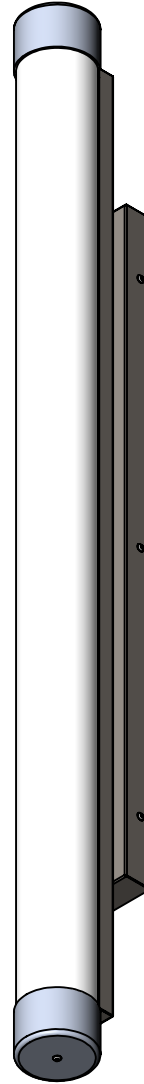
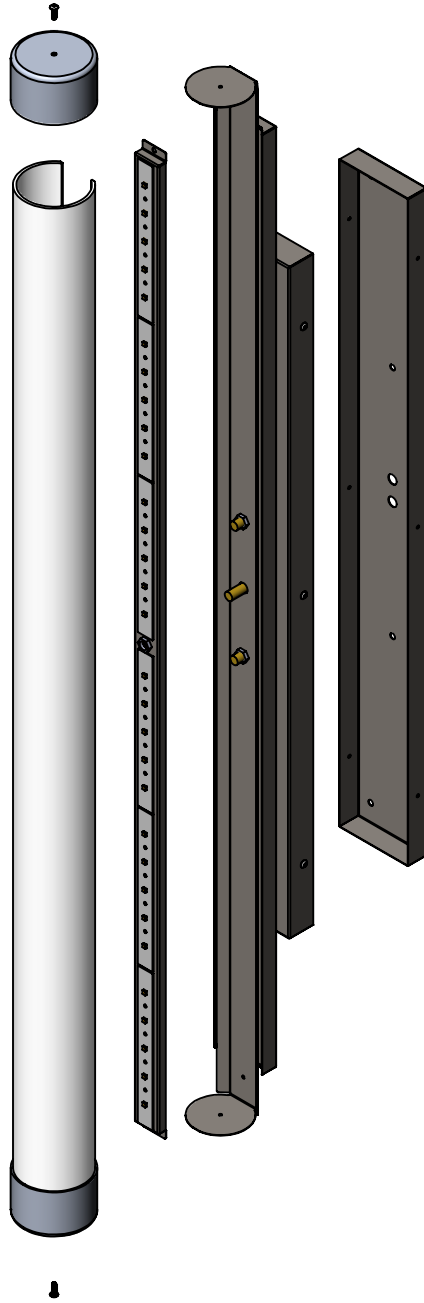
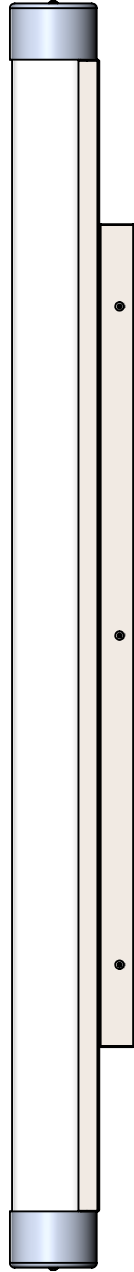
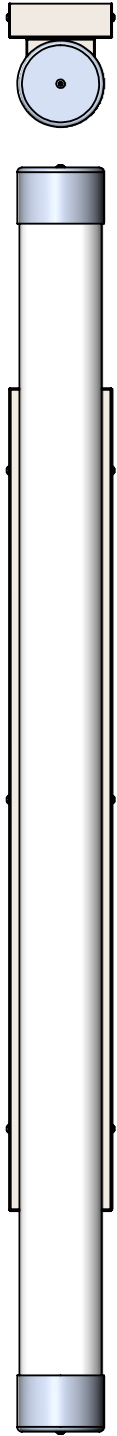

***ALL COMPONENTS TO BE SPOT
WELDED INTO ONE PIECE**

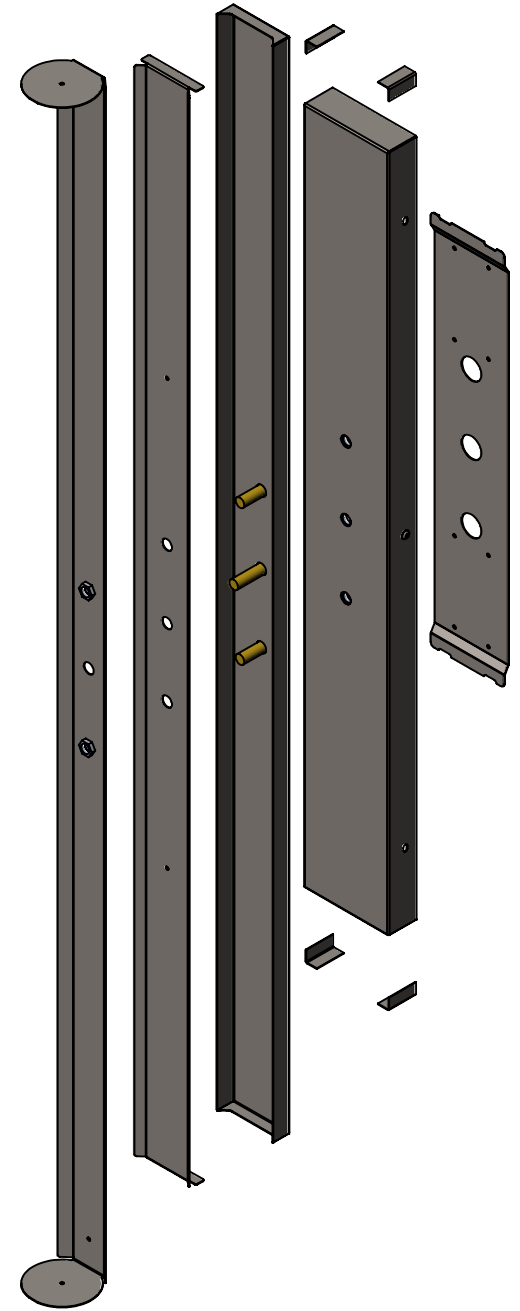
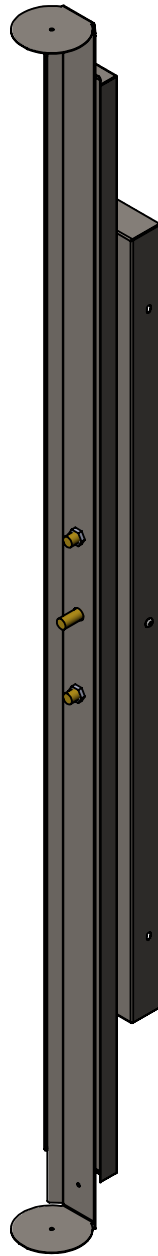

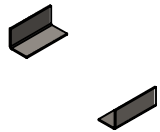
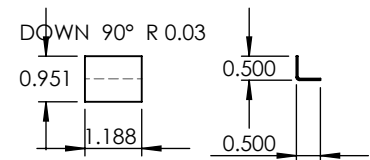
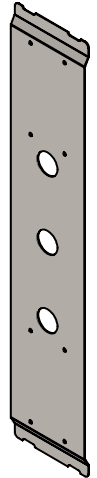
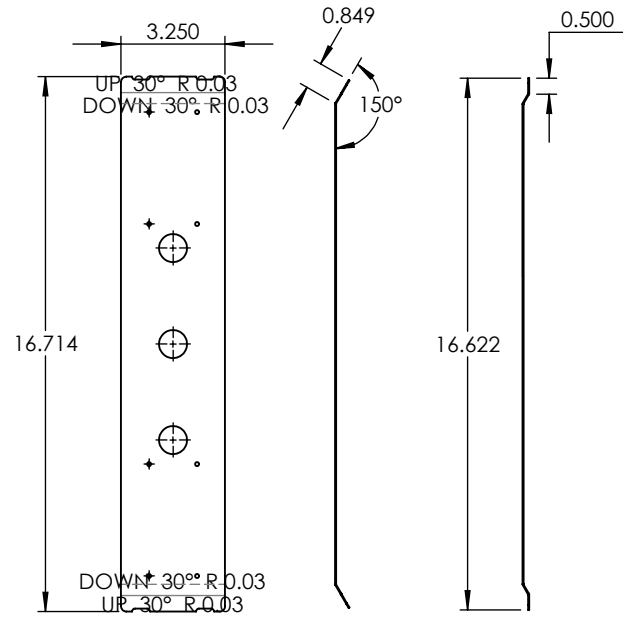
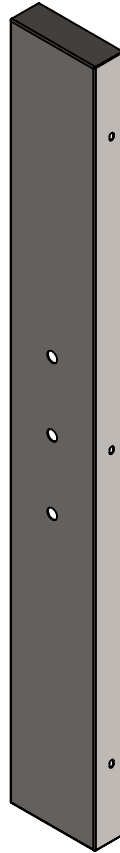
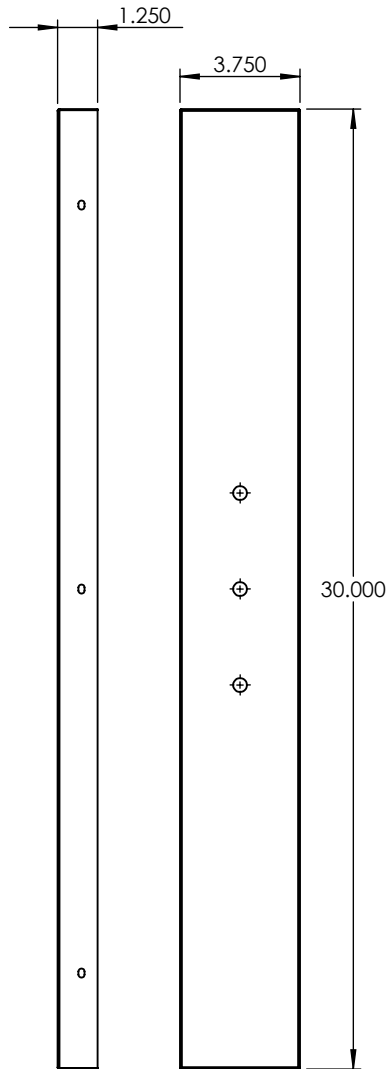
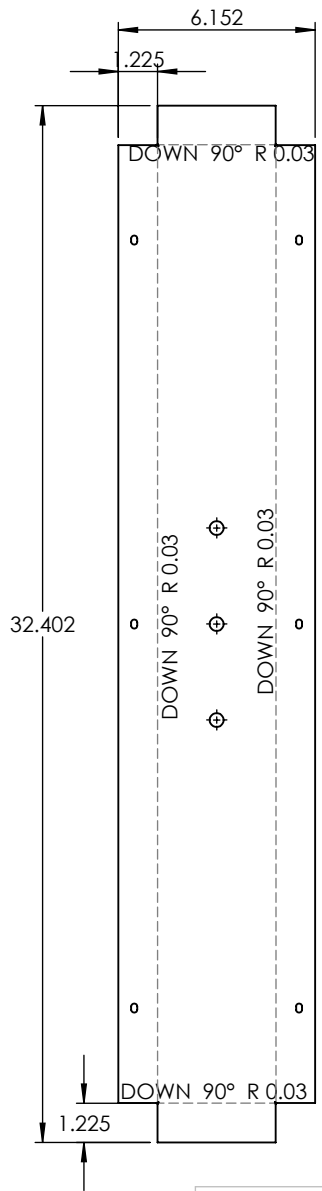

UNLESS OTHERWISE SPECIFIED:

DIMENSIONS ARE IN INCHES
 TOLERANCES:
 FRACTIONAL ±
 ANGULAR: MACH ± BEND ±
 TWO PLACE DECIMAL ±
 THREE PLACE DECIMAL ±

INTERPRET GEOMETRIC
 TOLERANCING PER:

MATERIAL

FINISH

DO NOT SCALE DRAWING

	NAME	DATE
DRAWN		
CHECKED		
ENG APPR.		
MFG APPR.		
Q.A.		
COMMENTS:		

22 GAUGE

TITLE:

CYL-VBB-30W-MBK-WF-DIM-46"-30K

SIZE	DWG. NO.	REV
A		

SCALE: 1:6 WEIGHT: SHEET 4 OF 11

PROPRIETARY AND CONFIDENTIAL
 THE INFORMATION CONTAINED IN THIS
 DRAWING IS THE SOLE PROPERTY OF
 <INSERT COMPANY NAME HERE>. ANY
 REPRODUCTION IN PART OR AS A WHOLE
 WITHOUT THE WRITTEN PERMISSION OF
 <INSERT COMPANY NAME HERE> IS
 PROHIBITED.

NEXT ASSY	USED ON	APPLICATION

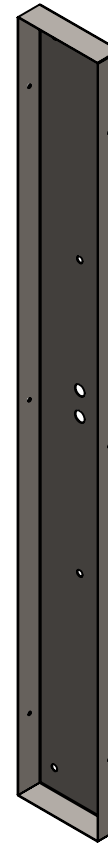
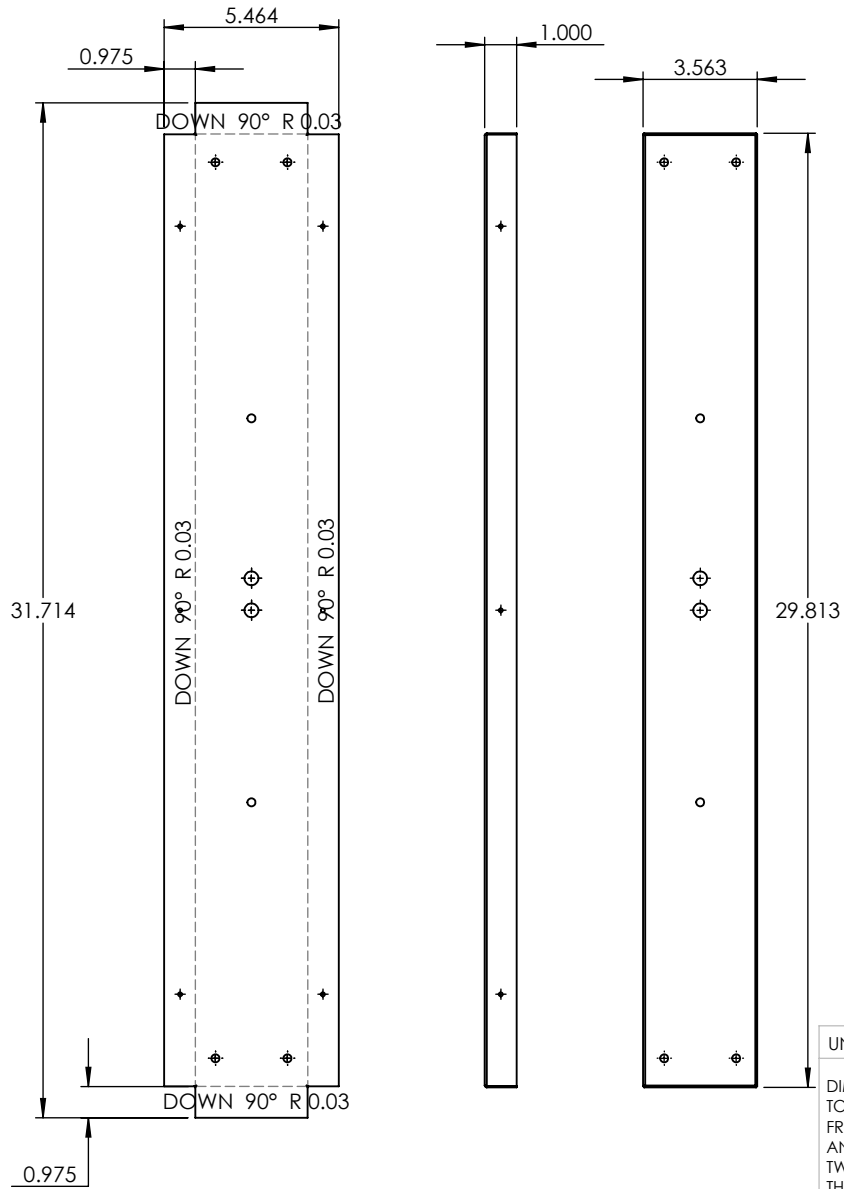

UNLESS OTHERWISE SPECIFIED:

DIMENSIONS ARE IN INCHES
 TOLERANCES:
 FRACTIONAL ±
 ANGULAR: MACH ± BEND ±
 TWO PLACE DECIMAL ±
 THREE PLACE DECIMAL ±

INTERPRET GEOMETRIC
 TOLERANCING PER:

MATERIAL

FINISH

DO NOT SCALE DRAWING

NAME

DATE

22 GAUGE

TITLE:

CYL-VBB-30W-MBK-WF-DIM-46"-30K

DRAWN

CHECKED

ENG APPR.

MFG APPR.

Q.A.

COMMENTS:

SIZE
A

DWG. NO.

REV

SCALE: 1:6

WEIGHT:

SHEET 5 OF 11

PROPRIETARY AND CONFIDENTIAL

THE INFORMATION CONTAINED IN THIS
 DRAWING IS THE SOLE PROPERTY OF
 <INSERT COMPANY NAME HERE>. ANY
 REPRODUCTION IN PART OR AS A WHOLE
 WITHOUT THE WRITTEN PERMISSION OF
 <INSERT COMPANY NAME HERE> IS
 PROHIBITED.

NEXT ASSY

USED ON

APPLICATION

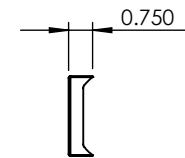
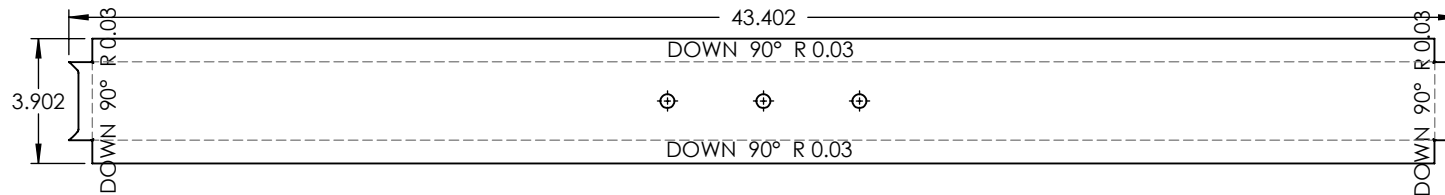
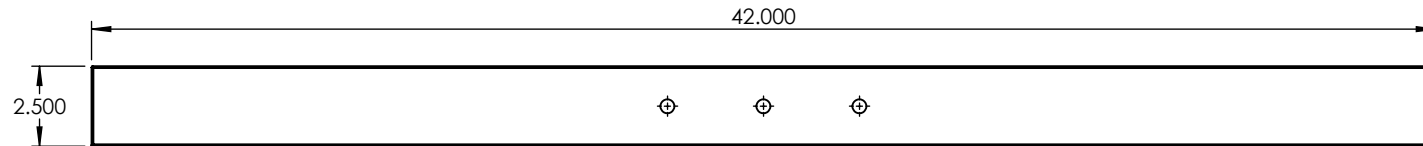
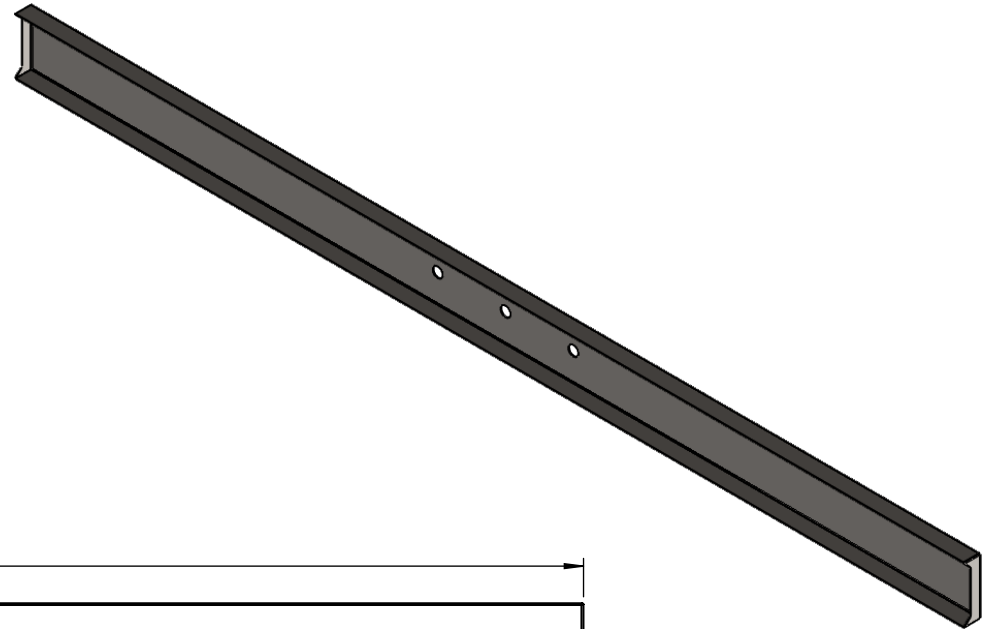

PROPRIETARY AND CONFIDENTIAL
 THE INFORMATION CONTAINED IN THIS DRAWING IS THE SOLE PROPERTY OF <INSERT COMPANY NAME HERE>. ANY REPRODUCTION IN PART OR AS A WHOLE WITHOUT THE WRITTEN PERMISSION OF <INSERT COMPANY NAME HERE> IS PROHIBITED.

		UNLESS OTHERWISE SPECIFIED:		NAME	DATE	22 GAUGE		
		DIMENSIONS ARE IN INCHES TOLERANCES: FRACTIONAL ± ANGULAR: MACH ± BEND ± TWO PLACE DECIMAL ± THREE PLACE DECIMAL ±	DRAWN			TITLE:		
		INTERPRET GEOMETRIC TOLERANCING PER:	CHECKED			CYL-VBB-30W-MBK-WF-DIM-46"-30K		
		MATERIAL	ENG APPR.			SIZE	DWG. NO.	REV
		FINISH	MFG APPR.			A		
NEXT ASSY	USED ON		Q.A.					
APPLICATION			COMMENTS:			SCALE: 1:6	WEIGHT:	SHEET 6 OF 11
		DO NOT SCALE DRAWING						

5

4

3

2

1

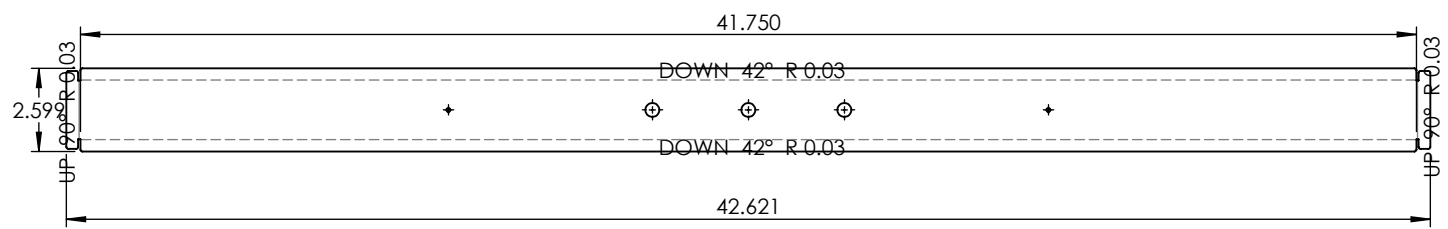
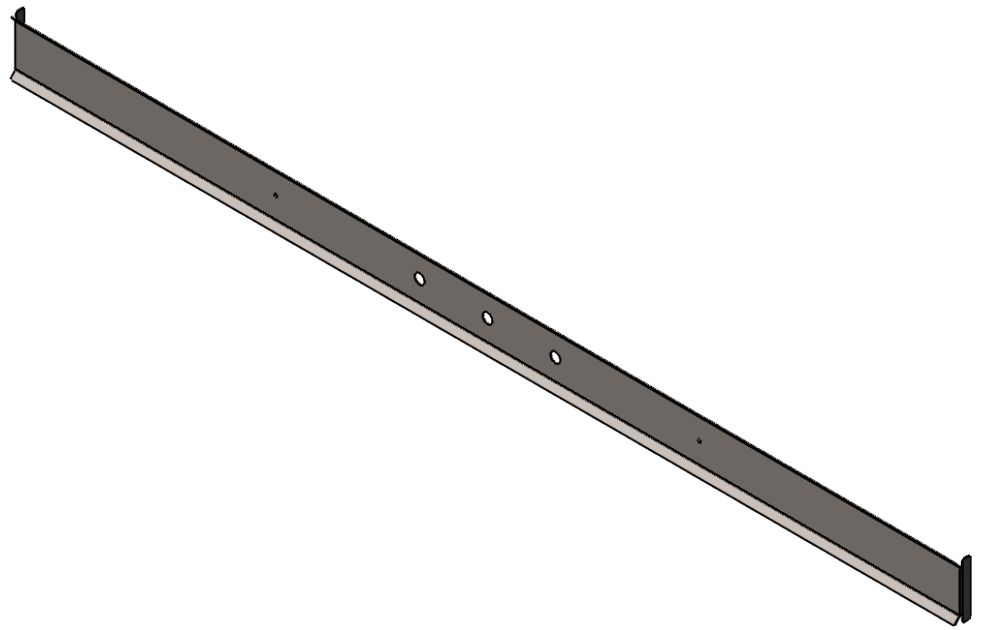
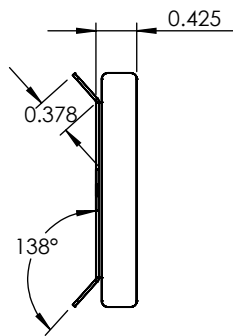

PROPRIETARY AND CONFIDENTIAL
 THE INFORMATION CONTAINED IN THIS DRAWING IS THE SOLE PROPERTY OF <INSERT COMPANY NAME HERE>. ANY REPRODUCTION IN PART OR AS A WHOLE WITHOUT THE WRITTEN PERMISSION OF <INSERT COMPANY NAME HERE> IS PROHIBITED.

NEXT ASSY	USED ON
APPLICATION	

UNLESS OTHERWISE SPECIFIED:
 DIMENSIONS ARE IN INCHES
 TOLERANCES:
 FRACTIONAL ±
 ANGULAR: MACH ± BEND ±
 TWO PLACE DECIMAL ±
 THREE PLACE DECIMAL ±

INTERPRET GEOMETRIC TOLERANCING PER:
 MATERIAL
 FINISH
 DO NOT SCALE DRAWING

	NAME	DATE
DRAWN		
CHECKED		
ENG APPR.		
MFG APPR.		
Q.A.		
COMMENTS:		

22 GAUGE		
TITLE: CYL-VBB-30W-MBK-WF-DIM-46"-30K		
SIZE A	DWG. NO.	REV
SCALE: 1:6	WEIGHT:	SHEET 7 OF 11

5

4

3

2

1

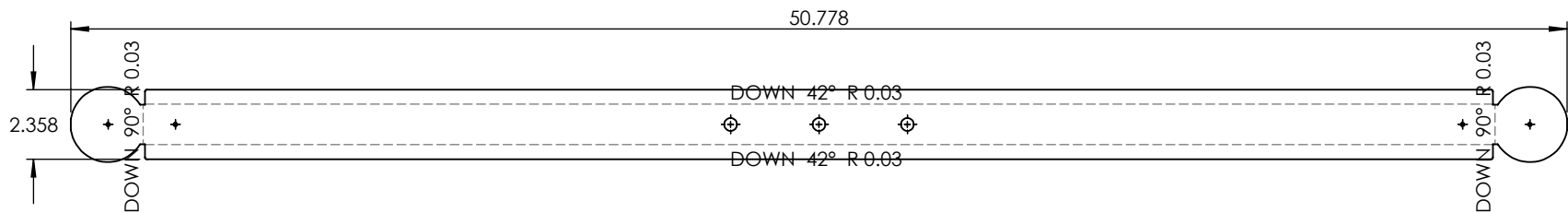
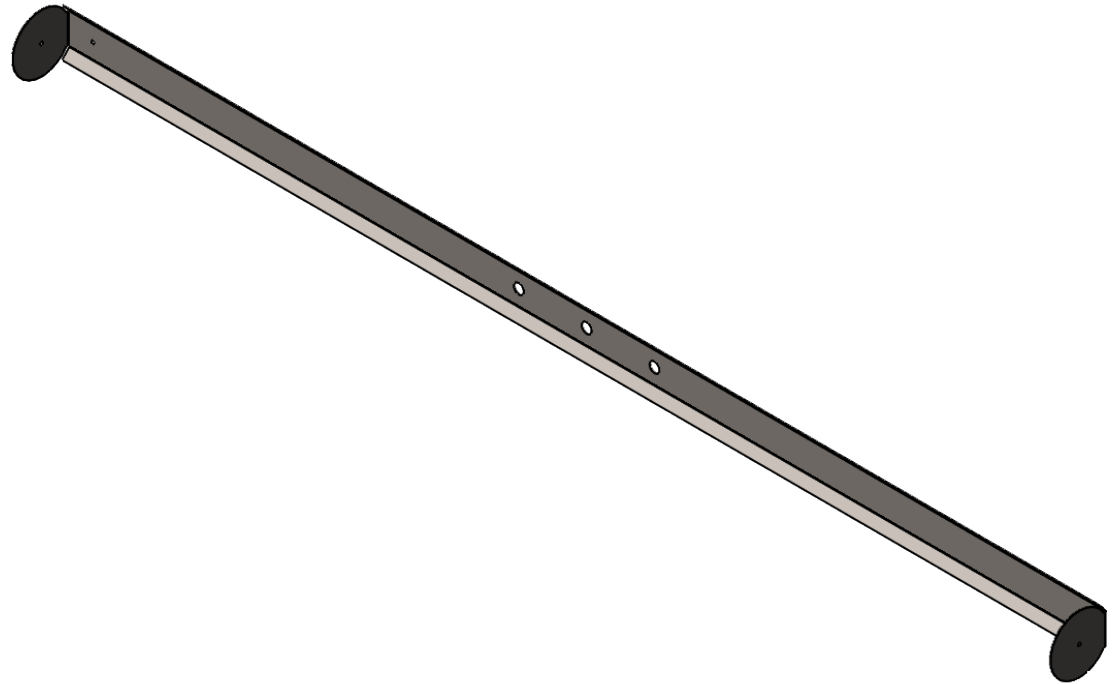
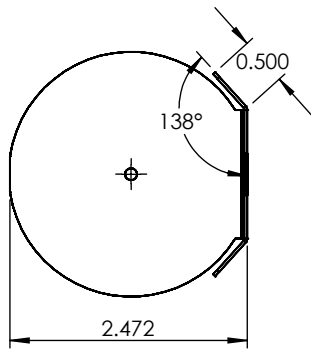

PROPRIETARY AND CONFIDENTIAL
 THE INFORMATION CONTAINED IN THIS DRAWING IS THE SOLE PROPERTY OF <INSERT COMPANY NAME HERE>. ANY REPRODUCTION IN PART OR AS A WHOLE WITHOUT THE WRITTEN PERMISSION OF <INSERT COMPANY NAME HERE> IS PROHIBITED.

NEXT ASSY	USED ON
APPLICATION	

UNLESS OTHERWISE SPECIFIED:
DIMENSIONS ARE IN INCHES
TOLERANCES:
FRACTIONAL ±
ANGULAR: MACH ± BEND ±
TWO PLACE DECIMAL ±
THREE PLACE DECIMAL ±
INTERPRET GEOMETRIC TOLERANCING PER:
MATERIAL
FINISH
DO NOT SCALE DRAWING

	NAME	DATE
DRAWN		
CHECKED		
ENG APPR.		
MFG APPR.		
Q.A.		
COMMENTS:		

22 GAUGE		
TITLE:		
CYL-VBB-30W-MBK-WF-DIM-46"-30K		
SIZE	DWG. NO.	REV
A		
SCALE: 1:6	WEIGHT:	SHEET 8 OF 11

5

4

3

2

1

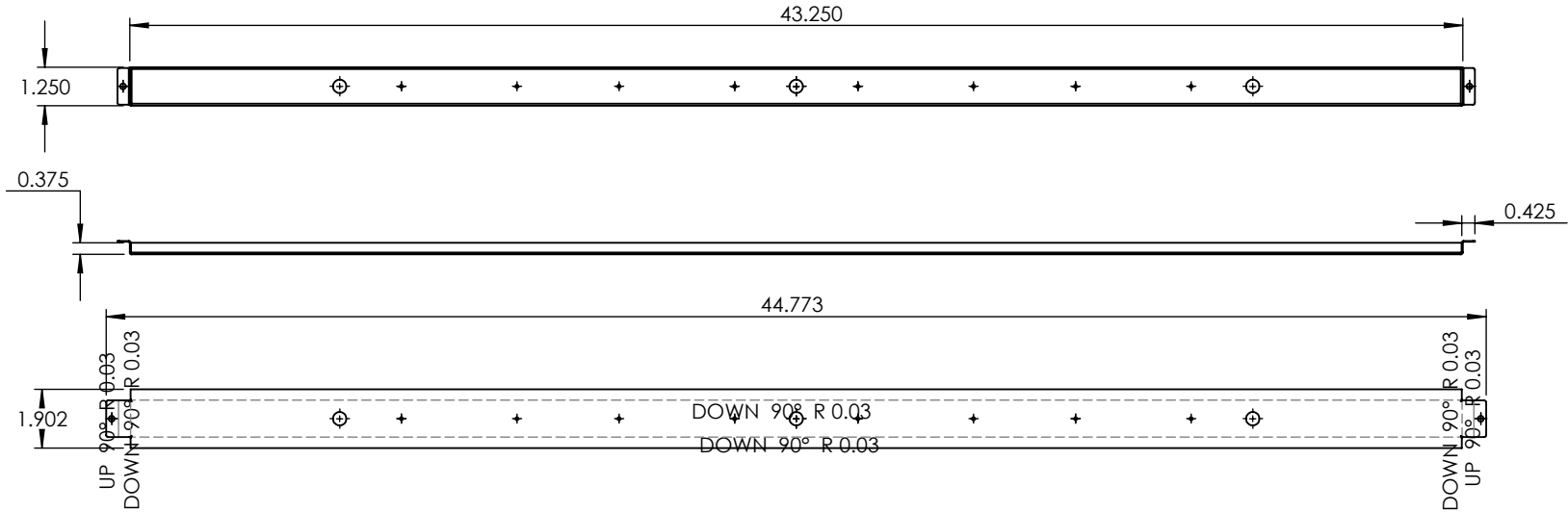
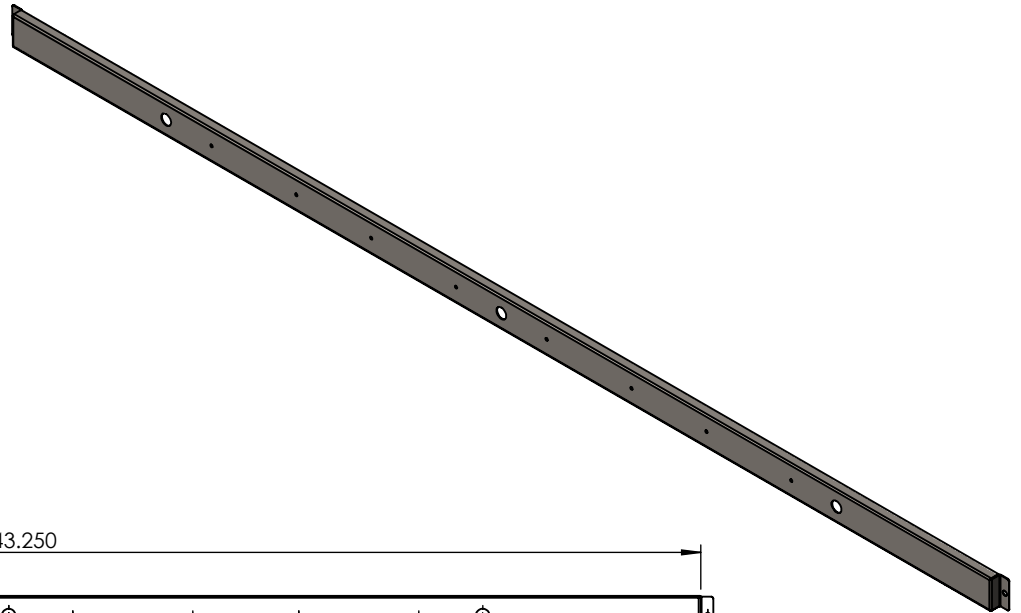

PROPRIETARY AND CONFIDENTIAL
 THE INFORMATION CONTAINED IN THIS DRAWING IS THE SOLE PROPERTY OF <INSERT COMPANY NAME HERE>. ANY REPRODUCTION IN PART OR AS A WHOLE WITHOUT THE WRITTEN PERMISSION OF <INSERT COMPANY NAME HERE> IS PROHIBITED.

NEXT ASSY	USED ON
APPLICATION	

UNLESS OTHERWISE SPECIFIED:
DIMENSIONS ARE IN INCHES
TOLERANCES:
FRACTIONAL ±
ANGULAR: MACH ± BEND ±
TWO PLACE DECIMAL ±
THREE PLACE DECIMAL ±
INTERPRET GEOMETRIC TOLERANCING PER:
MATERIAL
FINISH
DO NOT SCALE DRAWING

	NAME	DATE
DRAWN		
CHECKED		
ENG APPR.		
MFG APPR.		
Q.A.		
COMMENTS:		

22 GAUGE		
TITLE:		
CYL-VBB-30W-MBK-WF-DIM-46"-30K		
SIZE	DWG. NO.	REV
A		
SCALE: 1:6	WEIGHT:	SHEET 9 OF 11

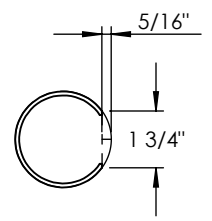
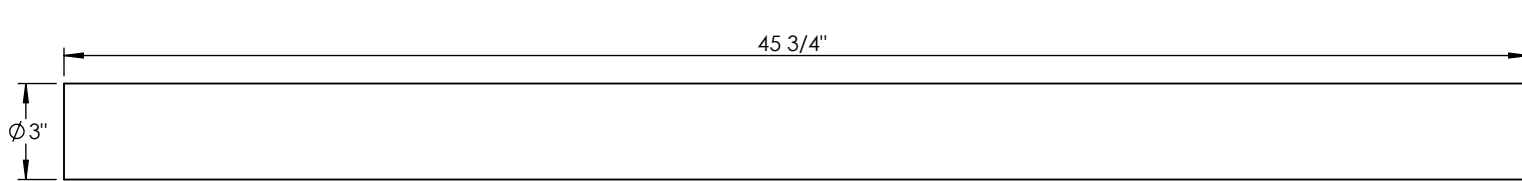
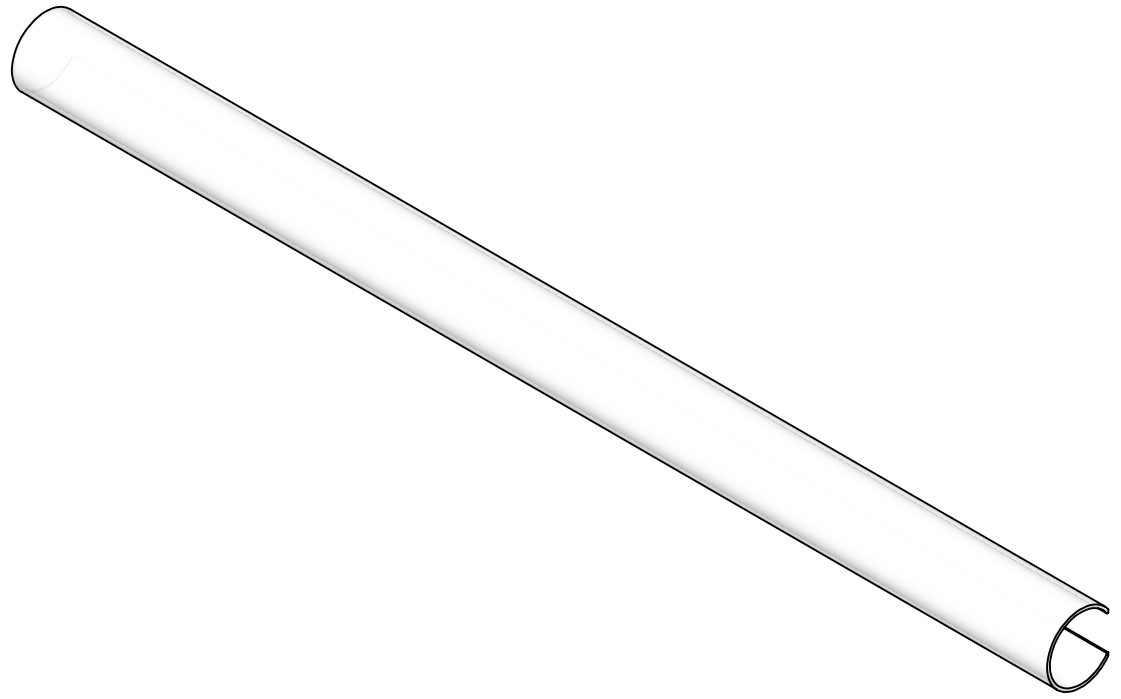

PROPRIETARY AND CONFIDENTIAL
 THE INFORMATION CONTAINED IN THIS DRAWING IS THE SOLE PROPERTY OF <INSERT COMPANY NAME HERE>. ANY REPRODUCTION IN PART OR AS A WHOLE WITHOUT THE WRITTEN PERMISSION OF <INSERT COMPANY NAME HERE> IS PROHIBITED.

		UNLESS OTHERWISE SPECIFIED:		NAME	DATE
		DIMENSIONS ARE IN INCHES	DRAWN		
		TOLERANCES:	CHECKED		
		FRACTIONAL ±	ENG APPR.		
		ANGULAR: MACH ± BEND ±	MFG APPR.		
		TWO PLACE DECIMAL ±	Q.A.		
		THREE PLACE DECIMAL ±	COMMENTS:		
		INTERPRET GEOMETRIC TOLERANCING PER:			
		MATERIAL			
		FINISH			
NEXT ASSY	USED ON				
APPLICATION		DO NOT SCALE DRAWING			

ACRYLIC		
TITLE:		
CYL-VBB-30W-MBK-WF-DIM-46"-30K		
SIZE	DWG. NO.	REV
A		
SCALE: 1:6	WEIGHT:	SHEET 10 OF 11

5

4

3

2

1

ITEM NO.	PART NUMBER	DESCRIPTION	QTY.
1	CYL-VBB-30W-MBK-WF-DIM-46"-30K-SPUN CUP	SPUN ALUMINUM 0.080"	1

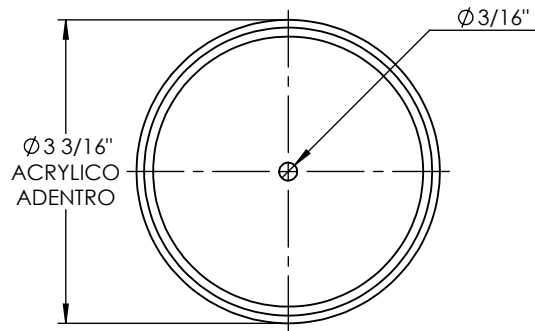
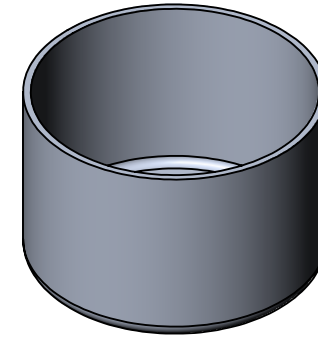
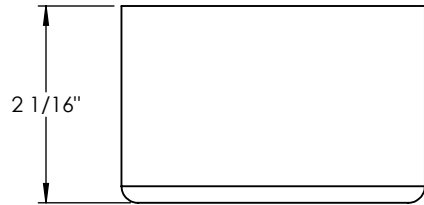

PROPRIETARY AND CONFIDENTIAL
 THE INFORMATION CONTAINED IN THIS DRAWING IS THE SOLE PROPERTY OF <INSERT COMPANY NAME HERE>. ANY REPRODUCTION IN PART OR AS A WHOLE WITHOUT THE WRITTEN PERMISSION OF <INSERT COMPANY NAME HERE> IS PROHIBITED.

		UNLESS OTHERWISE SPECIFIED:		NAME	DATE	SPUN ALUMINUM 0.080"	
		DIMENSIONS ARE IN INCHES	DRAWN			TITLE:	
		TOLERANCES:	CHECKED			CYL-VBB-30W-MBK-WF-DIM-46"-30K	
		FRACTIONAL ±	ENG APPR.			SIZE DWG. NO. REV	
		ANGULAR: MACH ± BEND ±	MFG APPR.			SCALE: 1:2 WEIGHT: SHEET 11 OF 11	
		TWO PLACE DECIMAL ±	Q.A.				
		THREE PLACE DECIMAL ±	COMMENTS:				
		INTERPRET GEOMETRIC TOLERANCING PER:					
		MATERIAL					
	NEXT ASSY	USED ON					
		FINISH					
	APPLICATION	DO NOT SCALE DRAWING					