

ITEM NO.	PART NUMBER	DESCRIPTION	QTY.	CUT
1	EV-MDW-1V-224T5HO-AB-WF-WET-28"-BACKPLATE	ALUMINUM 0.0635"	1	
2	EV-MDW-1V-224T5HO-AB-WF-WET-28"-FIREPLATE	ALUMINUM 0.0635"	1	
3	EV-MDW-1V-224T5HO-AB-WF-WET-28"-LENS RAIL	ALUMINUM 0.0635"	2	
4	EV-MDW-1V-224T5HO-AB-WF-WET-28"-END CAP	ALUMINUM 0.0635"	2	
5	EV-MDW-1V-224T5HO-AB-WF-WET-28"-VERTICAL STRAP	ALUMINUM 0.0635"	1	
6	EV-MDW-1V-224T5HO-AB-WF-WET-28"-END BRACKET	ALUMINUM 0.0635"	3	
7	EV-MDW-1V-224T5HO-AB-WF-WET-28"-ALUMINUM BAR	1"X1/2" ALUMINUM BAR	1	
8	EV-MDW-1V-224T5HO-AB-WF-WET-28"-ACRYLIC	ACRYLIC	1	
9	ACelectronics 226T4UVS1_120277v	BALLAST	1	
10	MINI-PIN	SOCKET PIN	4	

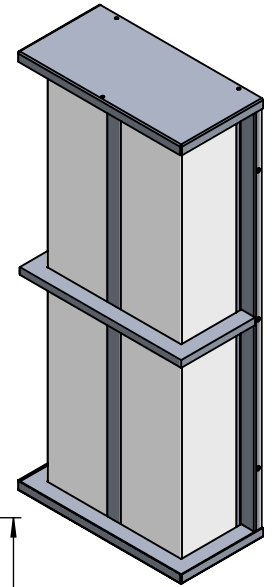
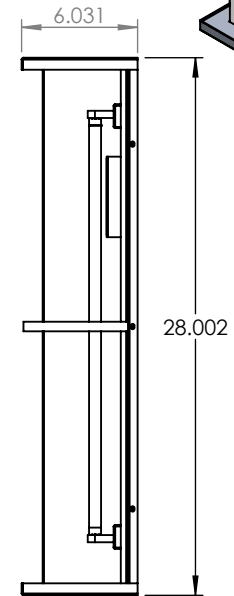
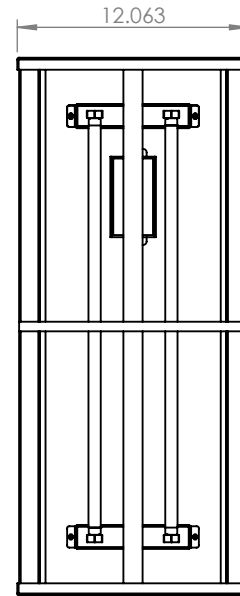
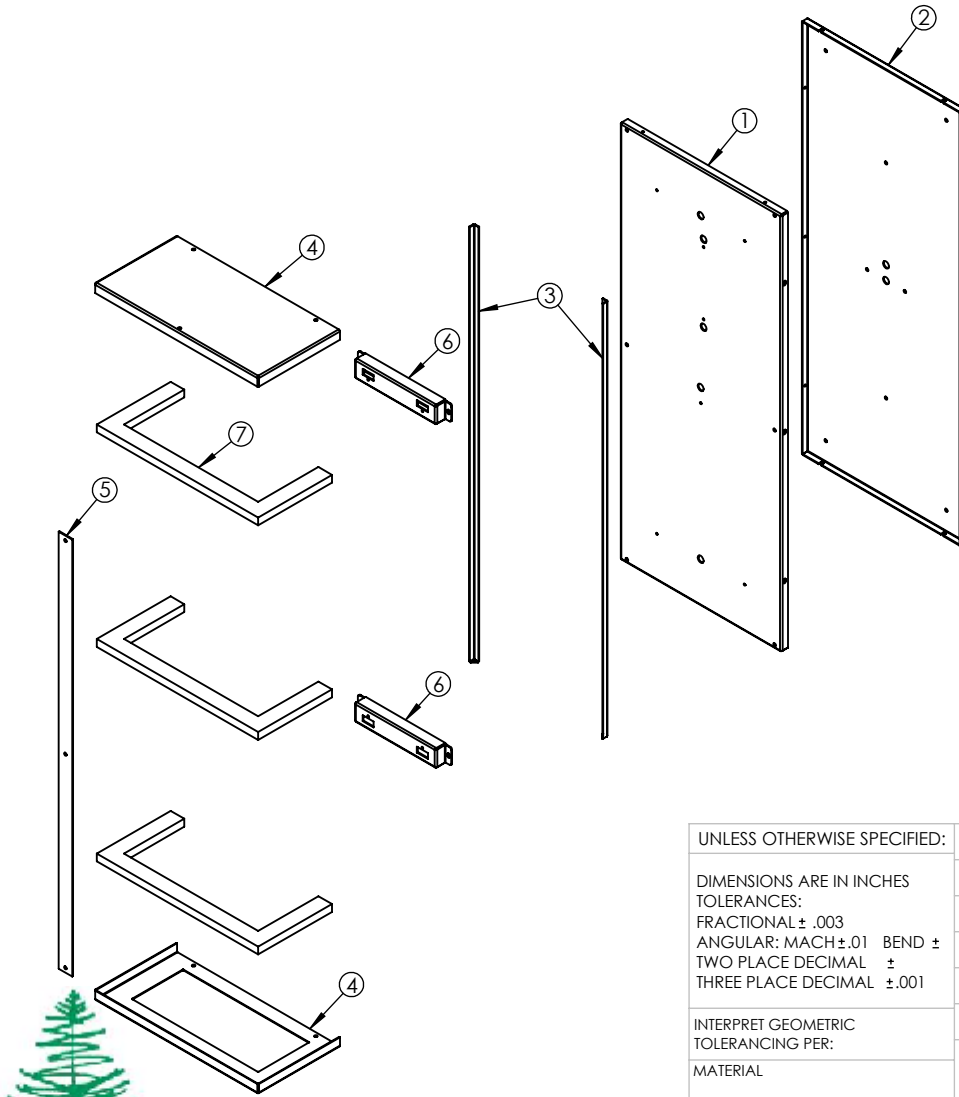

UNLESS OTHERWISE SPECIFIED:		NAME	DATE	TITLE:	
DIMENSIONS ARE IN INCHES		DRAWN		EV-MDW-1V-224T5HO-AB-WF-WET-28"	
TOLERANCES:		CHECKED			
FRACTIONAL ± .003		ENG APPR.			
ANGULAR: MACH ± .01 BEND ±		MFG APPR.			
TWO PLACE DECIMAL ±		Q.A.		SIZE DWG. NO. REV	
THREE PLACE DECIMAL ±.001		COMMENTS:		<b>A</b> TICKET 27240	
INTERPRET GEOMETRIC TOLERANCING PER:				SCALE: 1:10 WEIGHT: SHEET 1 OF 6	
MATERIAL					
FINISH					

**EVERGREEN LIGHTING**

ALL BEND RADIUS .030"

APPLICATION

DO NOT SCALE DRAWING

5

4

3

2

1

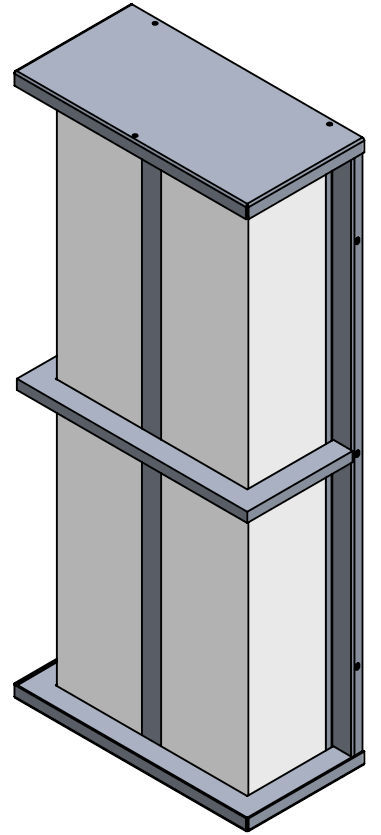
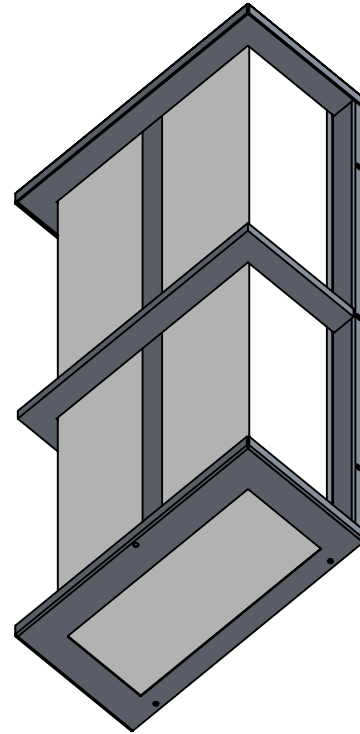
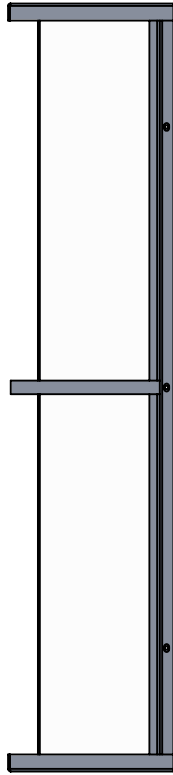
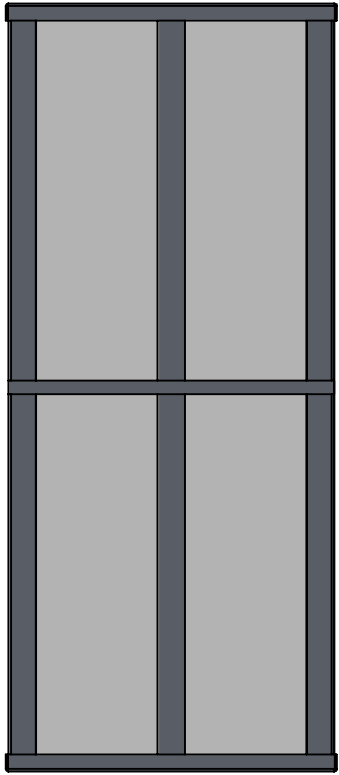
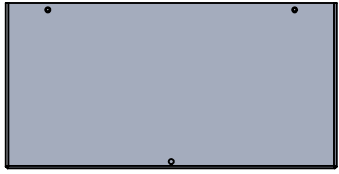

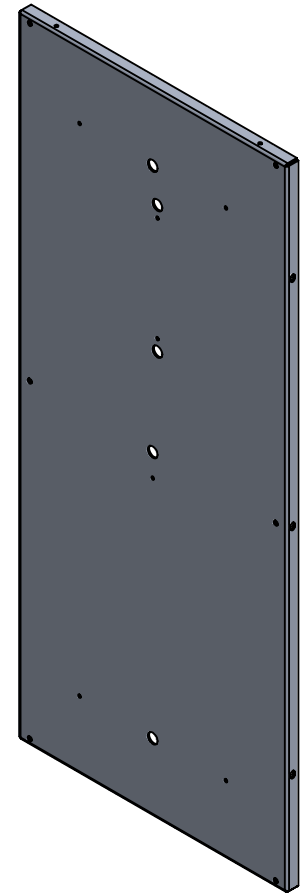
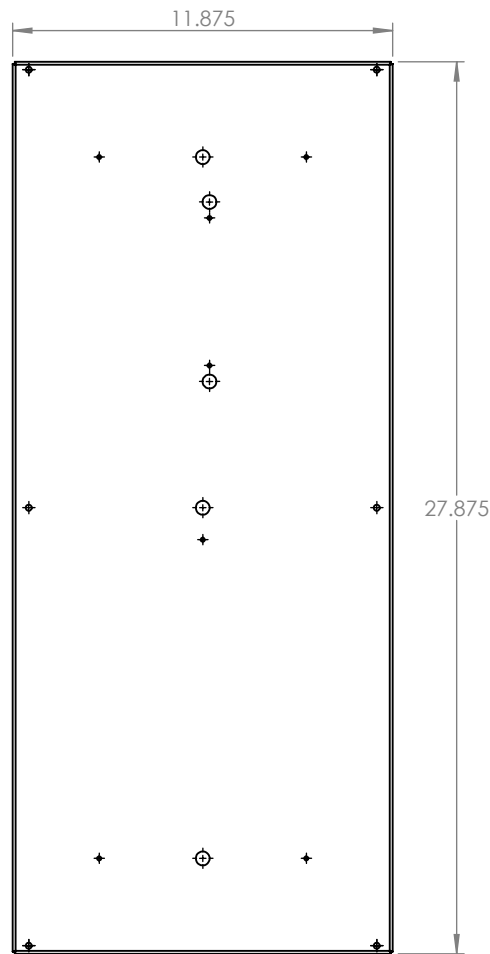
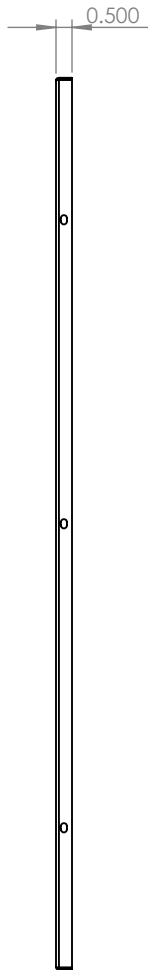
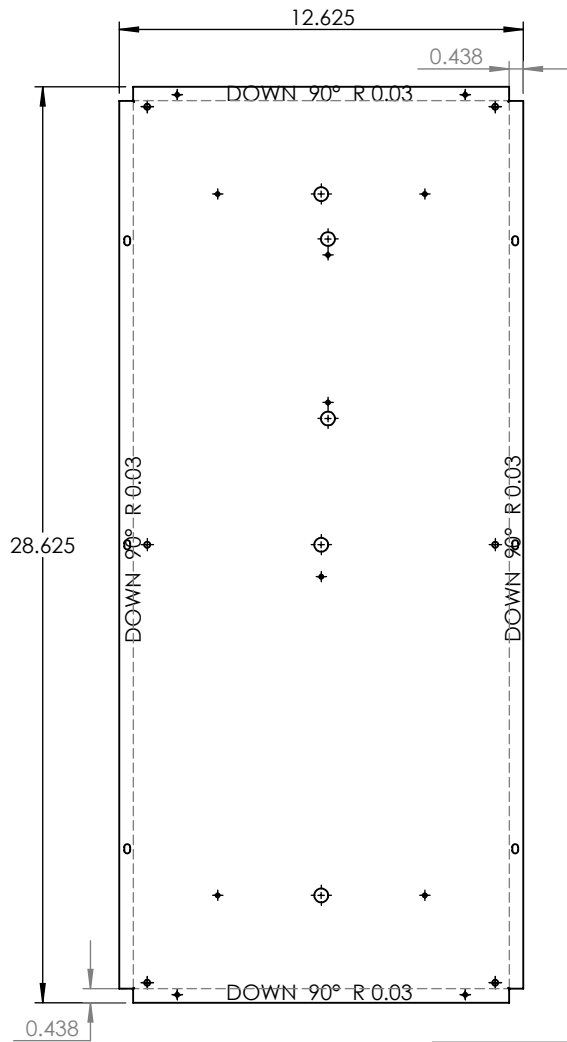

**PROPRIETARY AND CONFIDENTIAL**  
 THE INFORMATION CONTAINED IN THIS DRAWING IS THE SOLE PROPERTY OF <INSERT COMPANY NAME HERE>. ANY REPRODUCTION IN PART OR AS A WHOLE WITHOUT THE WRITTEN PERMISSION OF <INSERT COMPANY NAME HERE> IS PROHIBITED.

		UNLESS OTHERWISE SPECIFIED:	NAME	DATE
		DIMENSIONS ARE IN INCHES	DRAWN	
		TOLERANCES:	CHECKED	
		FRACTIONAL ±	ENG APPR.	
		ANGULAR: MACH ± BEND ±	MFG APPR.	
		TWO PLACE DECIMAL ±	Q.A.	
		THREE PLACE DECIMAL ±	COMMENTS:	
		INTERPRET GEOMETRIC TOLERANCING PER:		
		MATERIAL		
		FINISH		
NEXT ASSY	USED ON			
APPLICATION		DO NOT SCALE DRAWING		

ALUMINUM 0.0635"		
TITLE:		
EV-MDW-1V-224T5HO-AB-WF-WET-28"		
SIZE	DWG. NO.	REV
<b>A</b>		
SCALE: 1:6	WEIGHT:	SHEET 3 OF 6

5

4

3

2

1

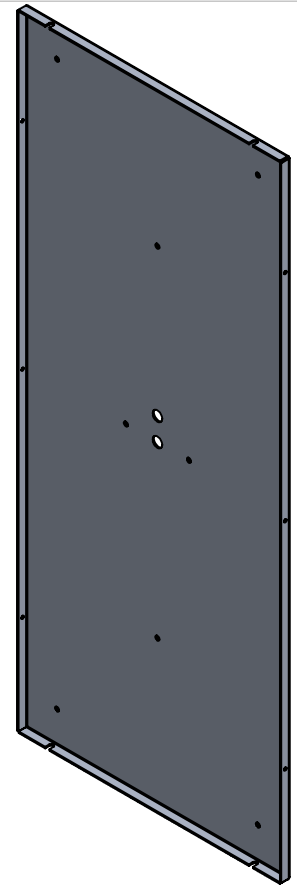
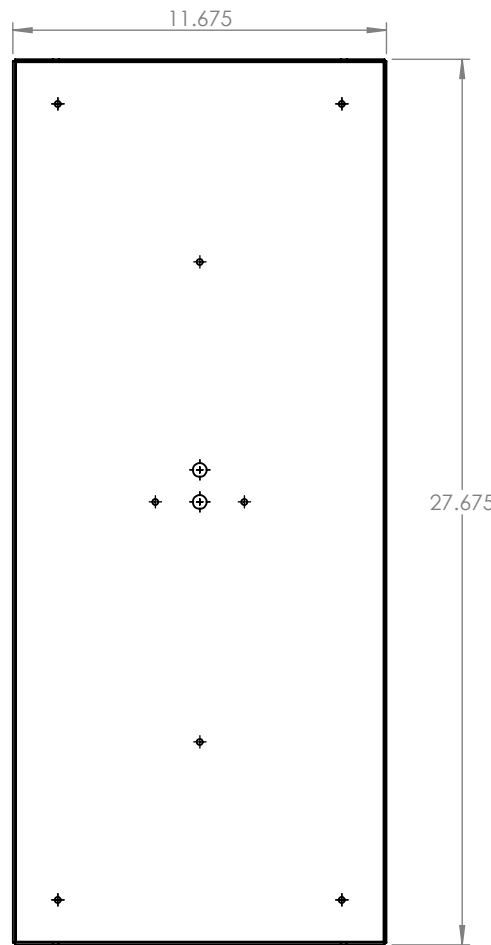
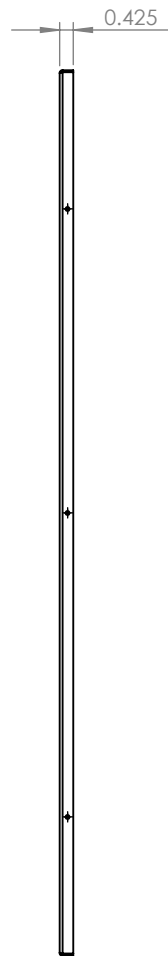
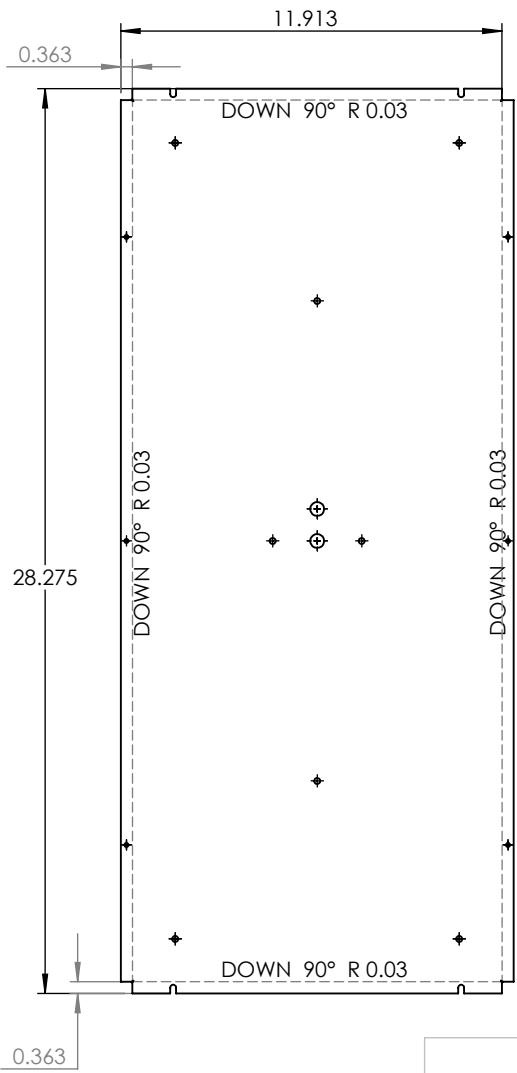

**PROPRIETARY AND CONFIDENTIAL**  
 THE INFORMATION CONTAINED IN THIS DRAWING IS THE SOLE PROPERTY OF <INSERT COMPANY NAME HERE>. ANY REPRODUCTION IN PART OR AS A WHOLE WITHOUT THE WRITTEN PERMISSION OF <INSERT COMPANY NAME HERE> IS PROHIBITED.

		UNLESS OTHERWISE SPECIFIED:		NAME	DATE
		DIMENSIONS ARE IN INCHES	DRAWN		
		TOLERANCES:	CHECKED		
		FRACTIONAL ±	ENG APPR.		
		ANGULAR: MACH ± BEND ±	MFG APPR.		
		TWO PLACE DECIMAL ±	Q.A.		
		THREE PLACE DECIMAL ±	COMMENTS:		
		INTERPRET GEOMETRIC TOLERANCING PER:			
		MATERIAL			
NEXT ASSY	USED ON	FINISH			
APPLICATION		DO NOT SCALE DRAWING			

ALUMINUM 0.0635"		
TITLE:		
EV-MDW-1V-224T5HO-AB-WF-WET-28"		
SIZE	DWG. NO.	REV
<b>A</b>		
SCALE: 1:6	WEIGHT:	SHEET 4 OF 6

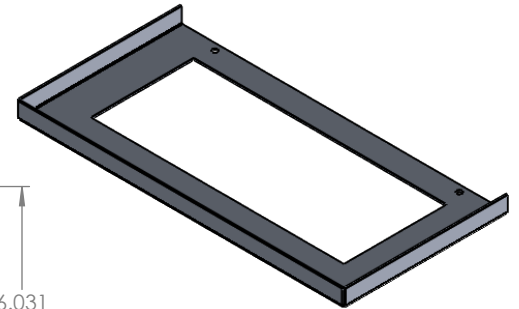
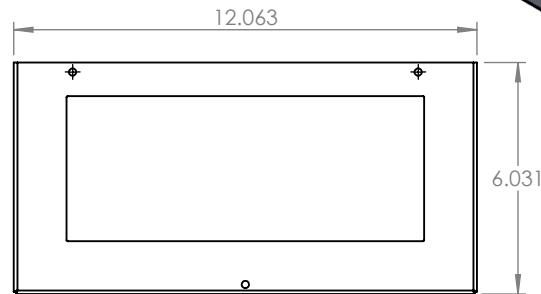
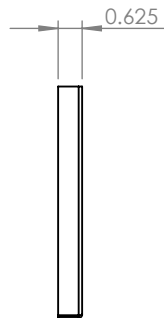
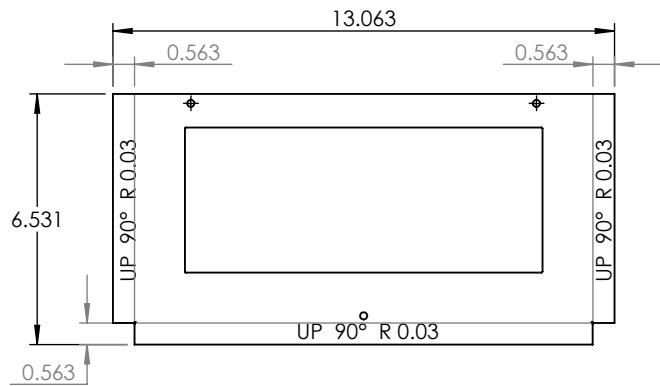
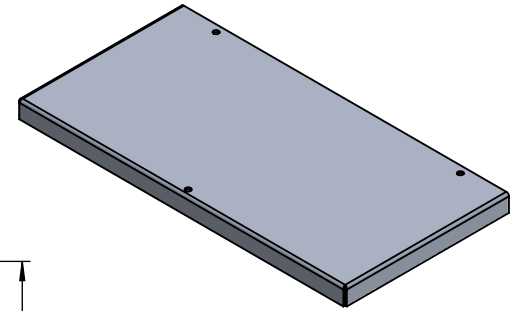
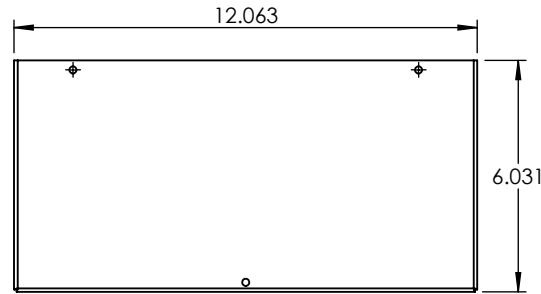
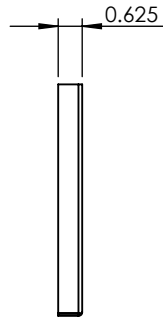
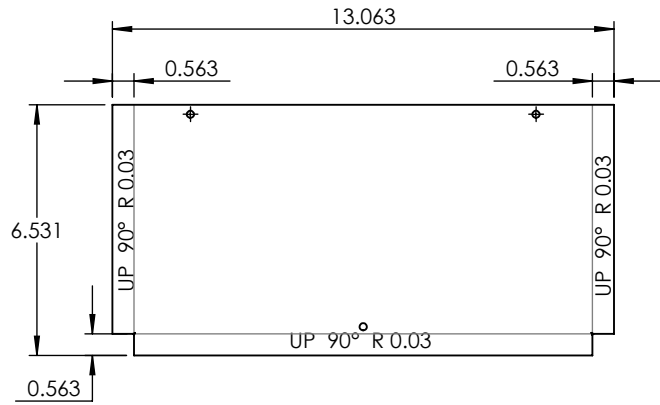

**PROPRIETARY AND CONFIDENTIAL**  
 THE INFORMATION CONTAINED IN THIS DRAWING IS THE SOLE PROPERTY OF <INSERT COMPANY NAME HERE>. ANY REPRODUCTION IN PART OR AS A WHOLE WITHOUT THE WRITTEN PERMISSION OF <INSERT COMPANY NAME HERE> IS PROHIBITED.

		UNLESS OTHERWISE SPECIFIED:	NAME	DATE
		DIMENSIONS ARE IN INCHES	DRAWN	
		TOLERANCES:	CHECKED	
		FRACTIONAL ±	ENG APPR.	
		ANGULAR: MACH ± BEND ±	MFG APPR.	
		TWO PLACE DECIMAL ±	Q.A.	
		THREE PLACE DECIMAL ±	COMMENTS:	
		INTERPRET GEOMETRIC TOLERANCING PER:		
		MATERIAL		
		FINISH		
NEXT ASSY	USED ON			
APPLICATION		DO NOT SCALE DRAWING		

ALUMINUM 0.0635"

TITLE:  
 EV-MDW-1V-224T5HO-AB-WF-WET-28"

SIZE	DWG. NO.	REV
<b>A</b>		
SCALE: 1:5	WEIGHT:	SHEET 5 OF 6

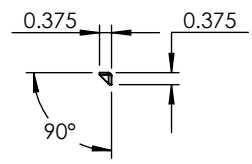
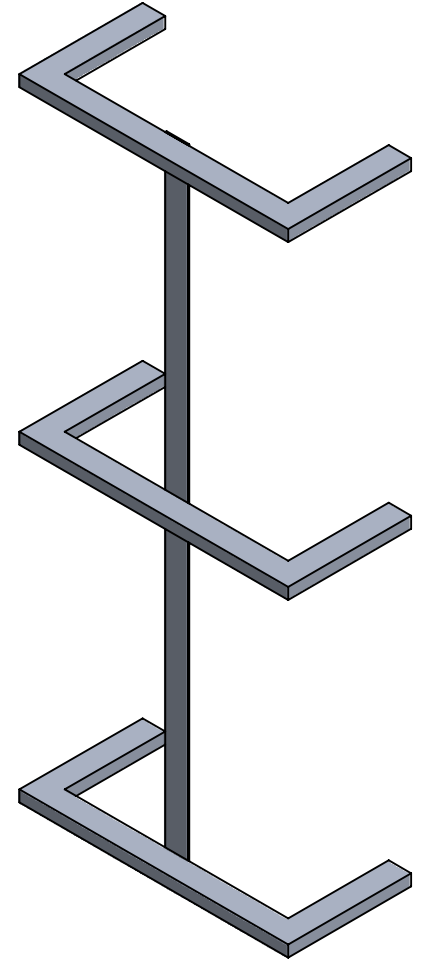
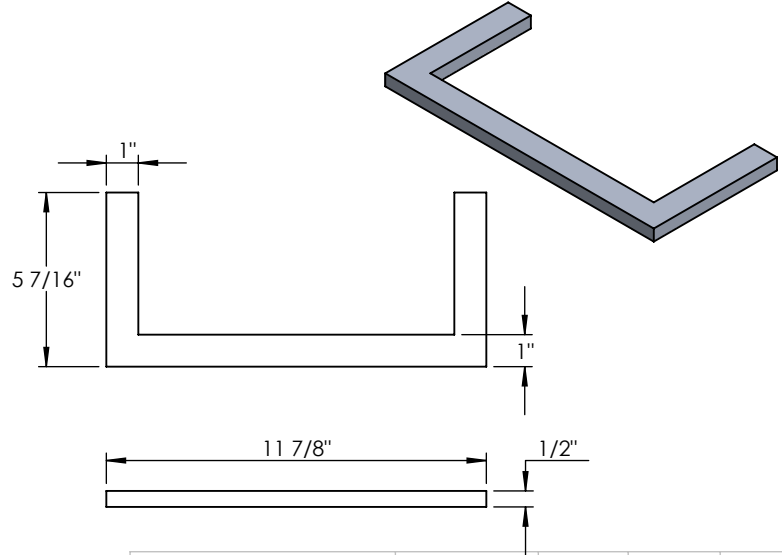
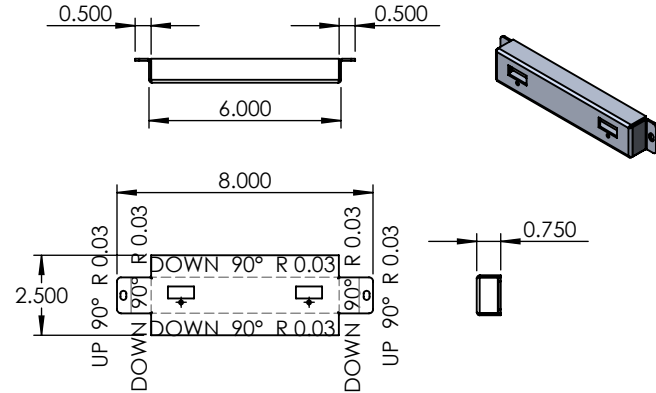
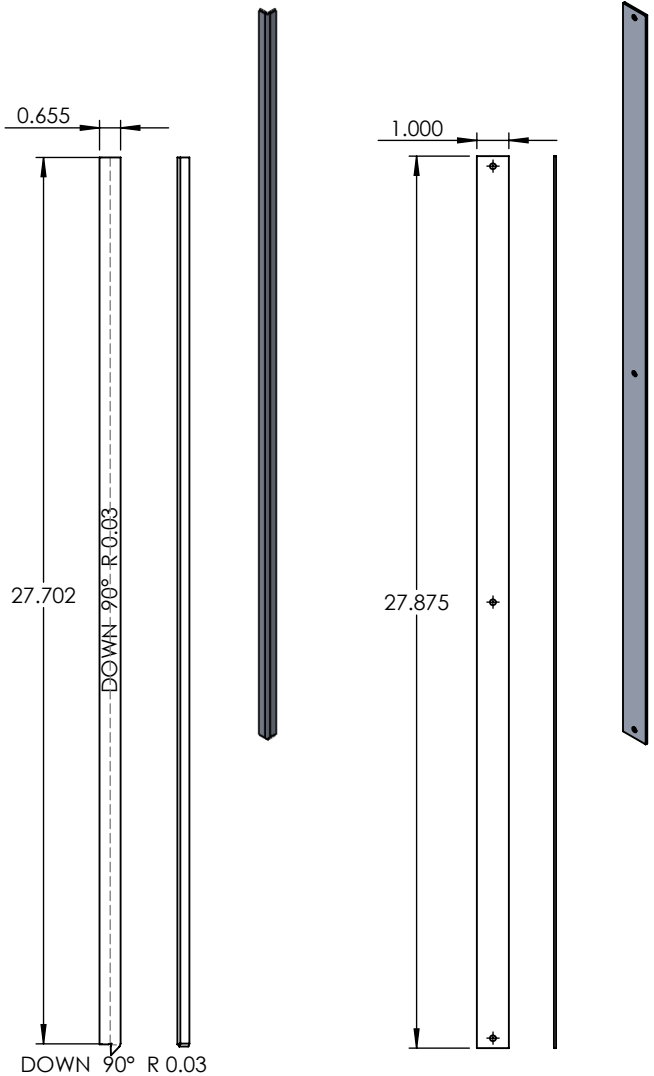

**PROPRIETARY AND CONFIDENTIAL**  
 THE INFORMATION CONTAINED IN THIS DRAWING IS THE SOLE PROPERTY OF <INSERT COMPANY NAME HERE>. ANY REPRODUCTION IN PART OR AS A WHOLE WITHOUT THE WRITTEN PERMISSION OF <INSERT COMPANY NAME HERE> IS PROHIBITED.

NEXT ASSY	USED ON
APPLICATION	

UNLESS OTHERWISE SPECIFIED:
DIMENSIONS ARE IN INCHES
TOLERANCES:
FRACTIONAL ±
ANGULAR: MACH ± BEND ±
TWO PLACE DECIMAL ±
THREE PLACE DECIMAL ±
INTERPRET GEOMETRIC TOLERANCING PER:
MATERIAL
FINISH
DO NOT SCALE DRAWING

	NAME	DATE
DRAWN		
CHECKED		
ENG APPR.		
MFG APPR.		
Q.A.		
COMMENTS:		

1"X1/2" ALUMINUM BAR		
TITLE:		
EV-MDW-1V-224T5HO-AB-WF-WET-28"		
SIZE	DWG. NO.	REV
<b>A</b>		
SCALE: 1:6	WEIGHT:	SHEET 6 OF 6