

ITEM NO.	PART NUMBER	DESCRIPTION	QTY.	CUT
1	SQBR-36X10-20W-AB-WA-DIM-WET-27K-BACKPLATE	22 GAUGE	1	
2	SQBR-36X10-20W-AB-WA-DIM-WET-27K-LED SPACER	22 GAUGE	1	
3	SQBR-36X10-20W-AB-WA-DIM-WET-27K-SIDE PLATE	22 GAUGE	2	
4	SQBR-36X10-20W-AB-WA-DIM-WET-27K-UPPER PLATE	22 GAUGE	2	
5	SQBR-36X10-20W-AB-WA-DIM-WET-27K-ACRYLIC	ACRYLIC	1	
7	SQBR-36X10-20W-AB-WA-DIM-WET-27K-FIREPLATE	22 GAUGE	1	
8	SQBR-36X10-20W-AB-WA-DIM-WET-27K-ALUMINUM BAR	1/2" SQUARE ALUMINUM BAR	1	
9	DS-15W-350C1542010-3001	DRIVER	1	
10	KTLD-25-UV-700-VDIM-LA1	DRIVER	1	
11	AltaILED PN105B-11-SS	LED	6	

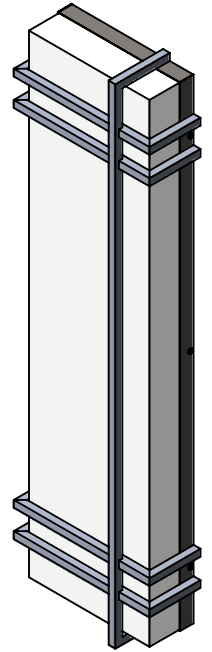
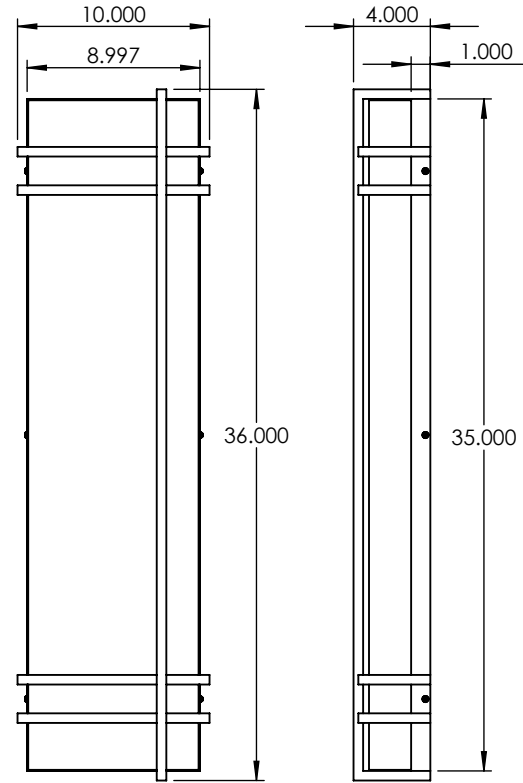
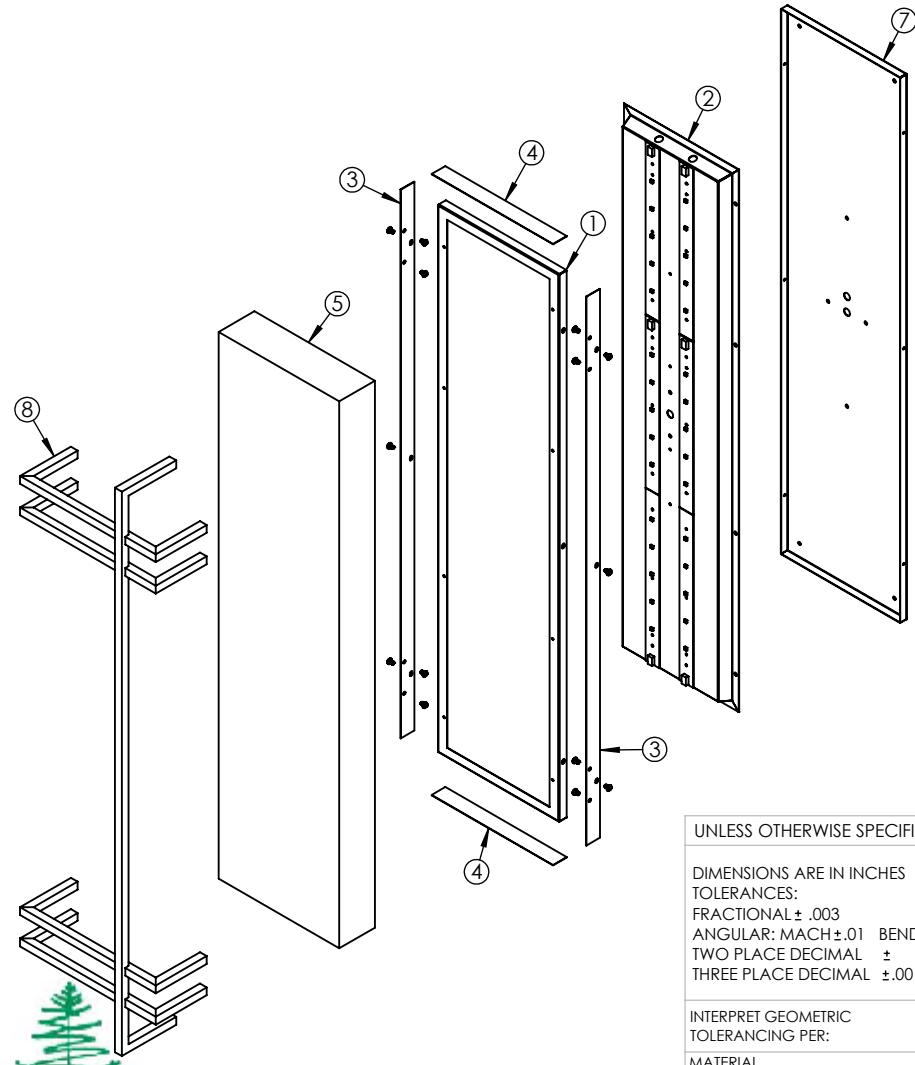

ALL BEND RADIUS .030"

APPLICATION

DO NOT SCALE DRAWING

UNLESS OTHERWISE SPECIFIED:

DIMENSIONS ARE IN INCHES  
 TOLERANCES:  
 FRACTIONAL ± .003  
 ANGULAR: MACH ± .01 BEND ±  
 TWO PLACE DECIMAL ±  
 THREE PLACE DECIMAL ±.001

INTERPRET GEOMETRIC  
 TOLERANCING PER:

MATERIAL

FINISH

NAME DATE

DRAWN  
 CHECKED  
 ENG APPR.  
 MFG APPR.

Q.A.  
 COMMENTS:

TITLE:

SQBR-36X10-20W-AB-WA-DIM-WET-27K

SIZE DWG. NO.

**A** TICKET 27319

REV

SCALE: 1:10 WEIGHT:

SHEET 1 OF 9

5

4

3

2

1

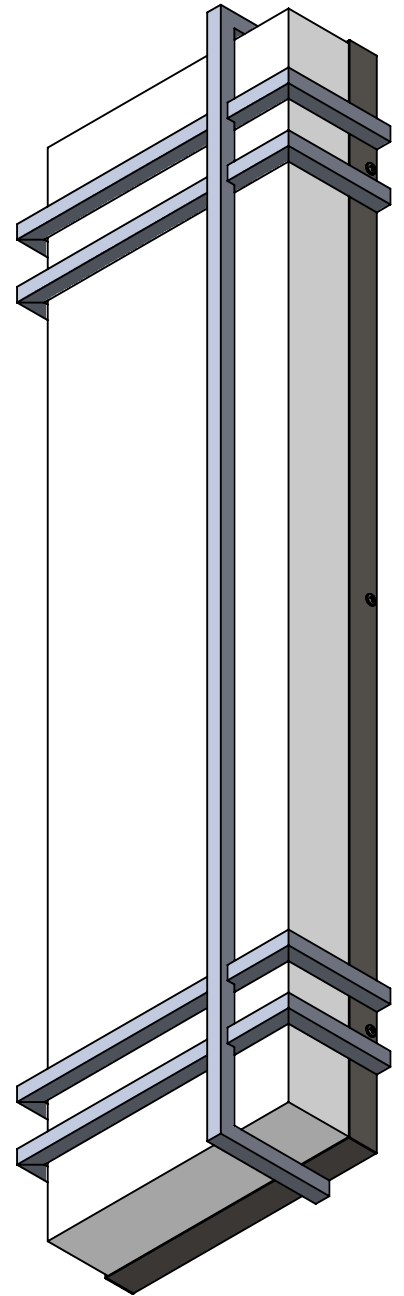
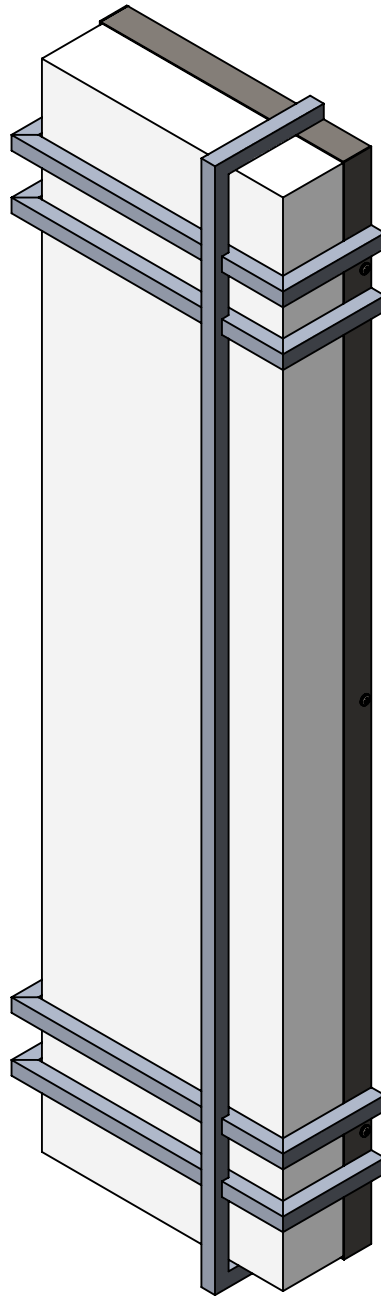
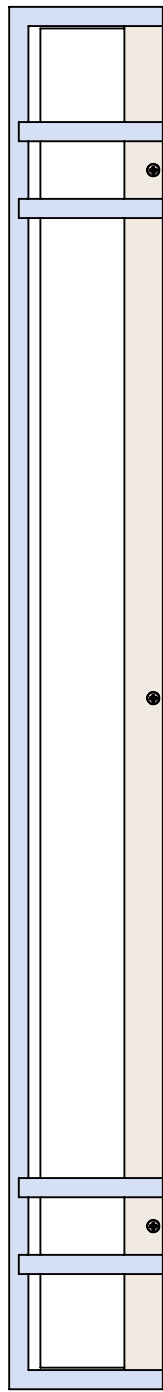
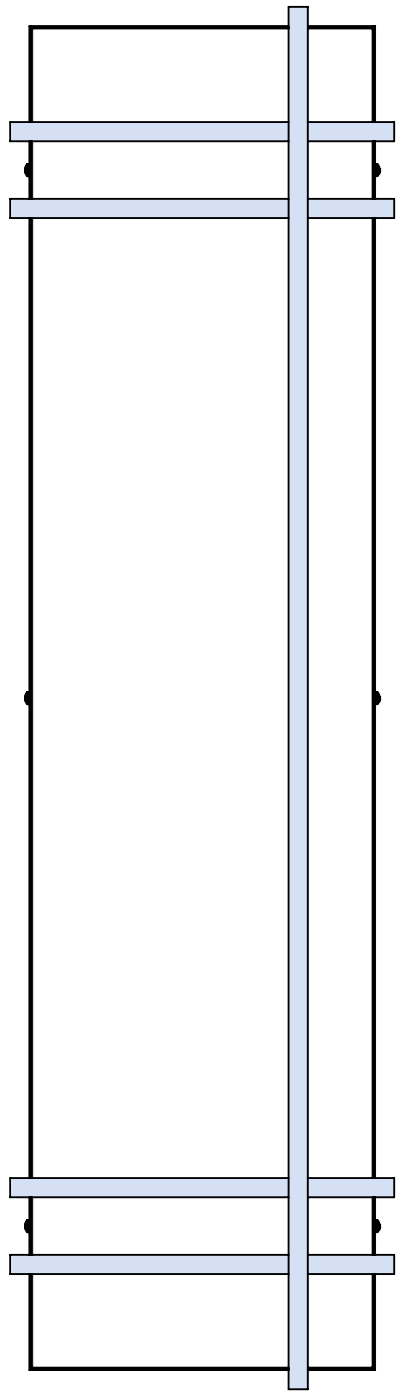

ALL SPOT WELDED TOGETHER INTO ONE PIECE

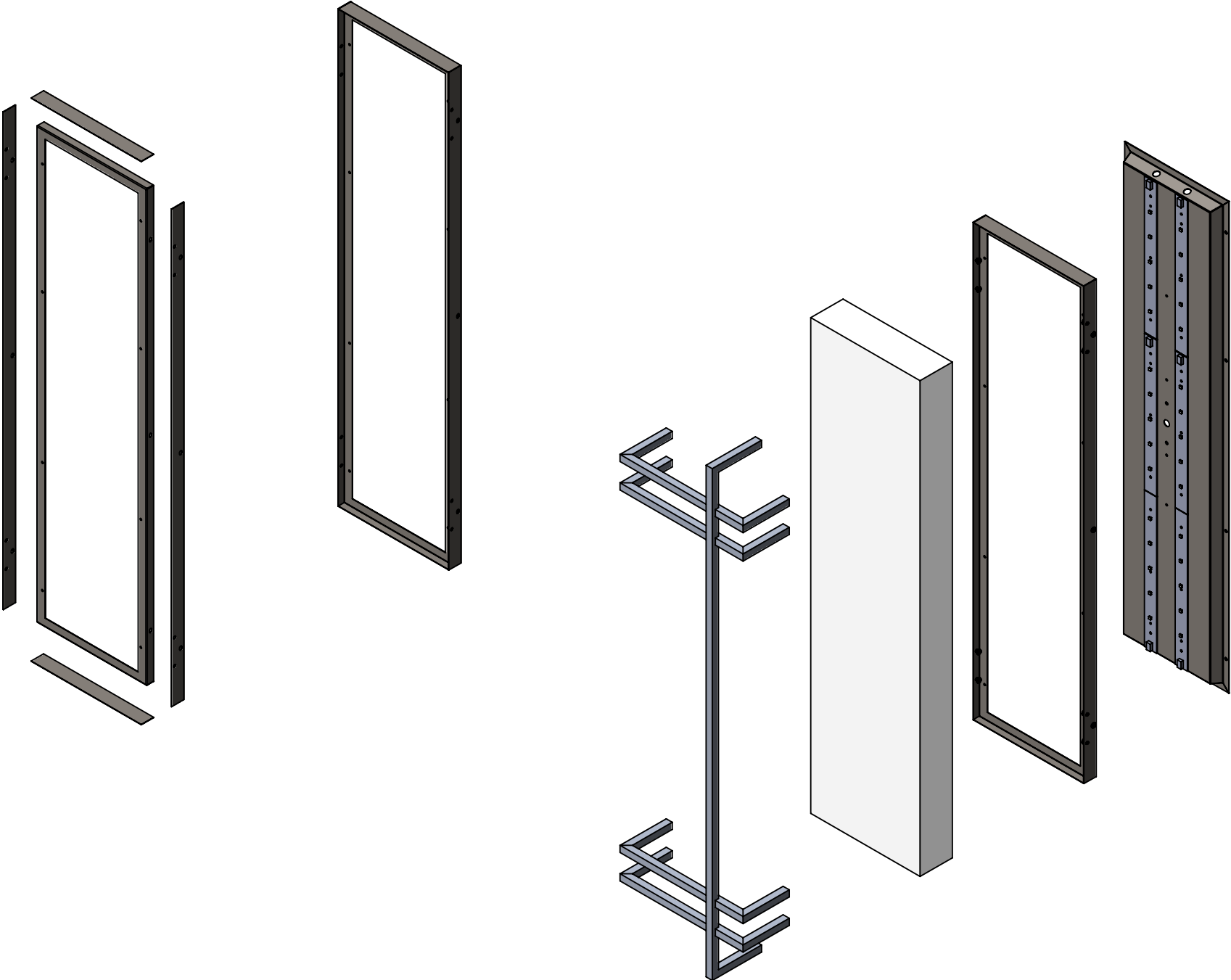

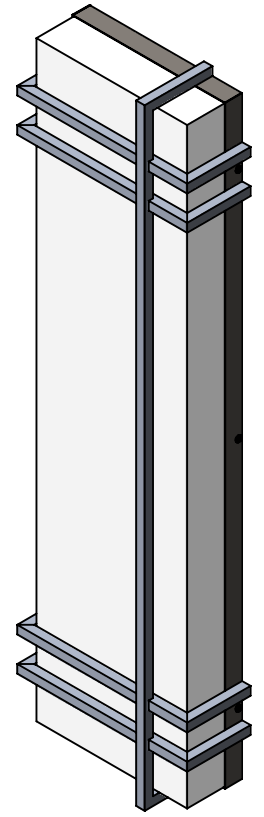
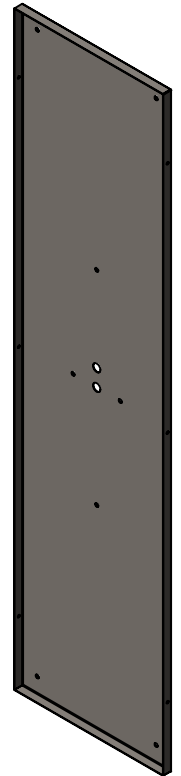
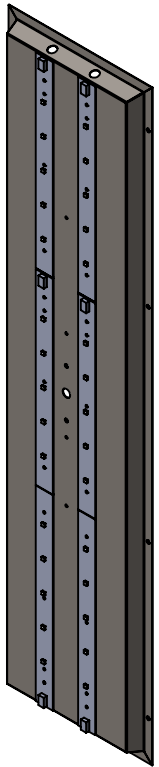
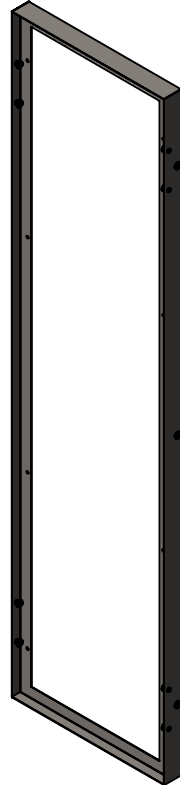
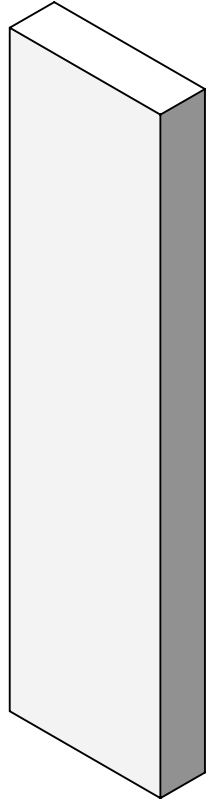
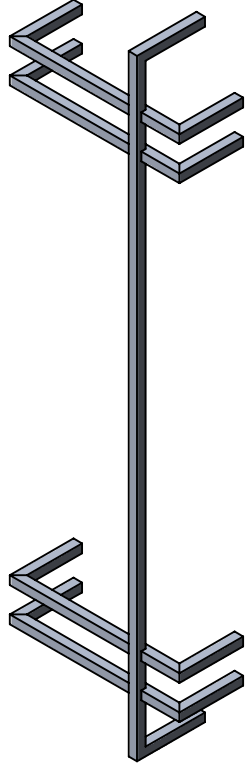

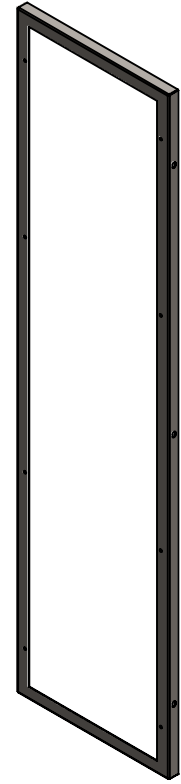
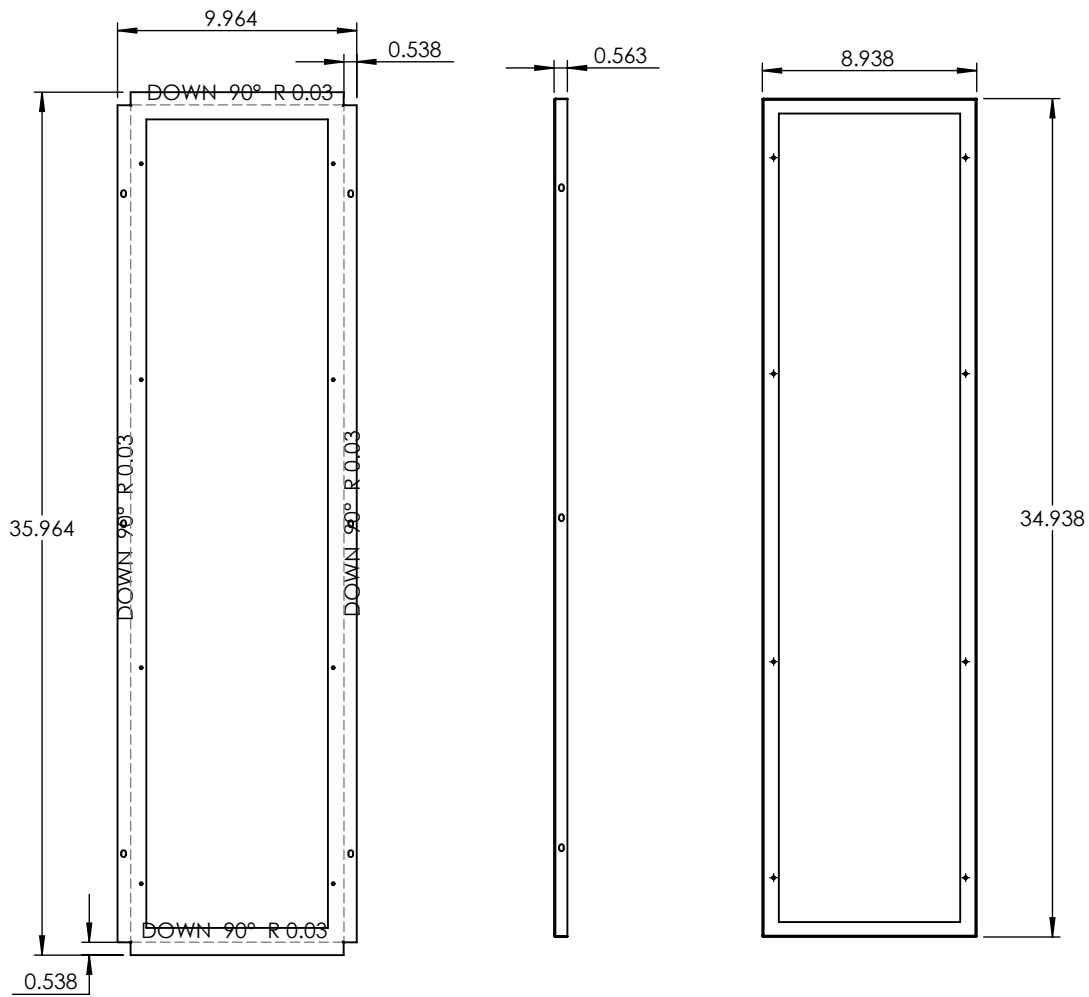

UNLESS OTHERWISE SPECIFIED:

DIMENSIONS ARE IN INCHES  
 TOLERANCES:  
 FRACTIONAL ±  
 ANGULAR: MACH ± BEND ±  
 TWO PLACE DECIMAL ±  
 THREE PLACE DECIMAL ±

INTERPRET GEOMETRIC TOLERANCING PER:

MATERIAL

FINISH

DO NOT SCALE DRAWING

NAME DATE

DRAWN  
 CHECKED  
 ENG APPR.  
 MFG APPR.

Q.A.

COMMENTS:

22 GAUGE

TITLE:  
 SQBR-36X10-20W-AB-WA-DIM-WET-27K

**PROPRIETARY AND CONFIDENTIAL**  
 THE INFORMATION CONTAINED IN THIS DRAWING IS THE SOLE PROPERTY OF <INSERT COMPANY NAME HERE>. ANY REPRODUCTION IN PART OR AS A WHOLE WITHOUT THE WRITTEN PERMISSION OF <INSERT COMPANY NAME HERE> IS PROHIBITED.

NEXT ASSY	USED ON
APPLICATION	

SIZE <b>A</b>	DWG. NO.	REV
SCALE: 1:8	WEIGHT:	SHEET 5 OF 9

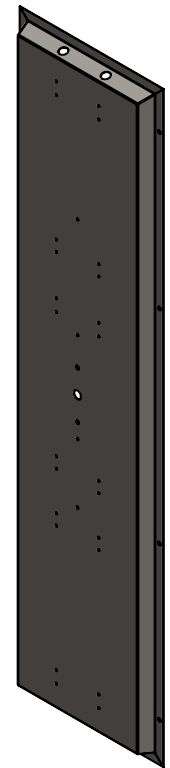
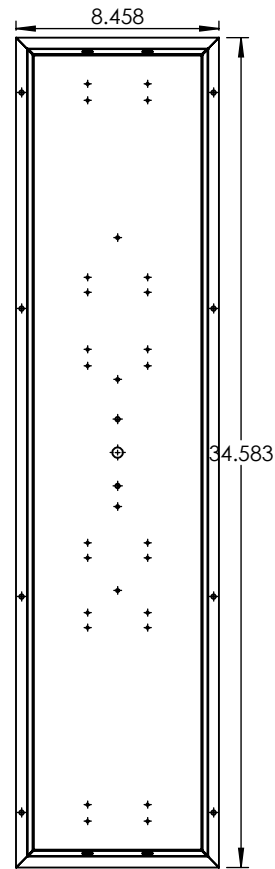
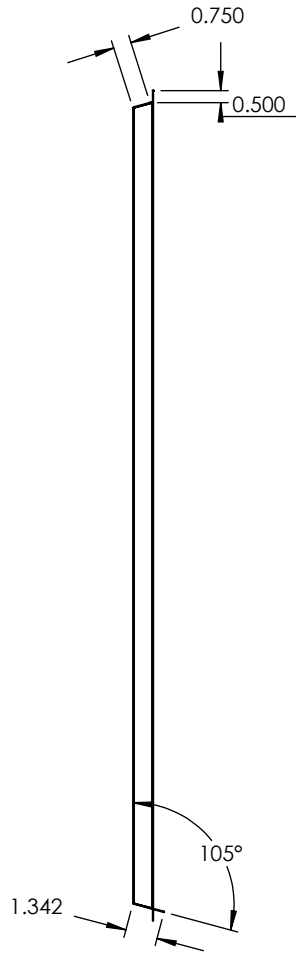
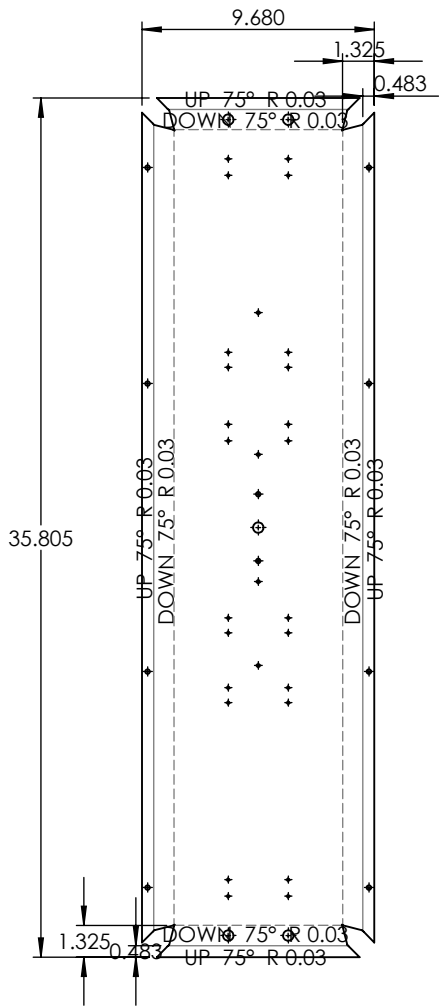

UNLESS OTHERWISE SPECIFIED:		NAME	DATE	22 GAUGE	
DIMENSIONS ARE IN INCHES TOLERANCES: FRACTIONAL ± ANGULAR: MACH ± BEND ± TWO PLACE DECIMAL ± THREE PLACE DECIMAL ±		DRAWN			
INTERPRET GEOMETRIC TOLERANCING PER:		CHECKED		SIZE DWG. NO. REV	
MATERIAL		ENG APPR.			
FINISH		MFG APPR.		COMMENTS:	
NEXT ASSY		Q.A.			
USED ON		COMMENTS:		APPLICATION	
APPLICATION					

**PROPRIETARY AND CONFIDENTIAL**  
THE INFORMATION CONTAINED IN THIS DRAWING IS THE SOLE PROPERTY OF <INSERT COMPANY NAME HERE>. ANY REPRODUCTION IN PART OR AS A WHOLE WITHOUT THE WRITTEN PERMISSION OF <INSERT COMPANY NAME HERE> IS PROHIBITED.

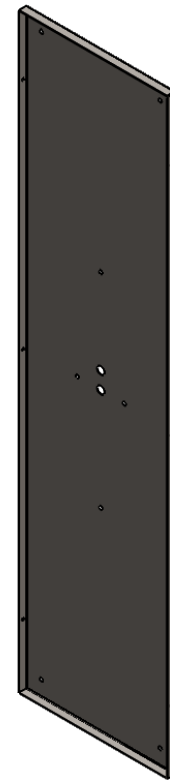
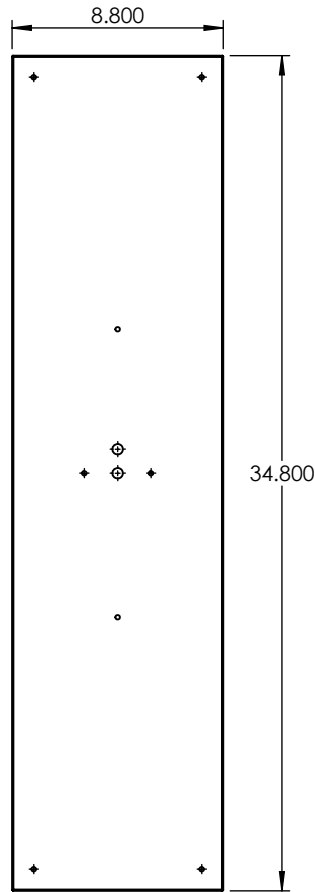
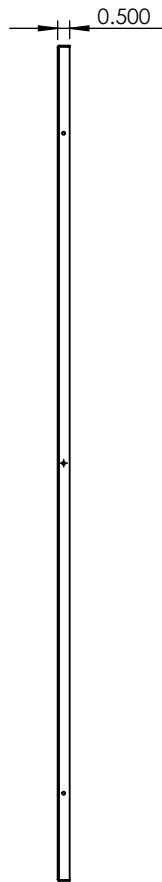
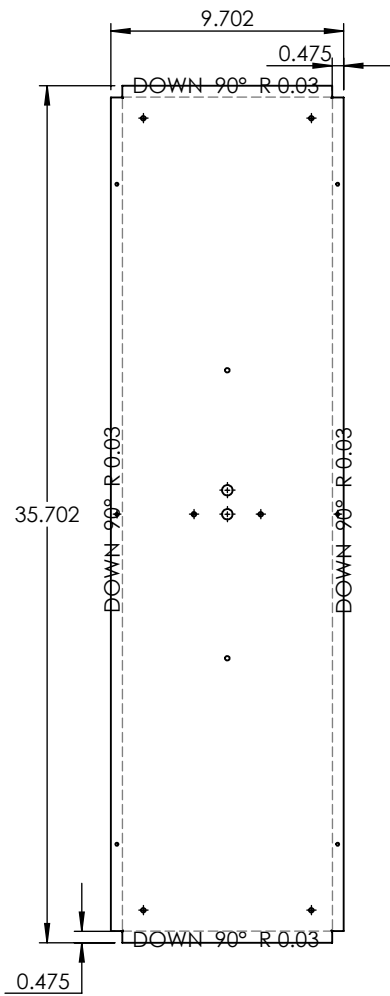

UNLESS OTHERWISE SPECIFIED:

DIMENSIONS ARE IN INCHES  
 TOLERANCES:  
 FRACTIONAL ±  
 ANGULAR: MACH ± BEND ±  
 TWO PLACE DECIMAL ±  
 THREE PLACE DECIMAL ±

INTERPRET GEOMETRIC  
 TOLERANCING PER:

MATERIAL

FINISH

DO NOT SCALE DRAWING

NAME

DATE

22 GAUGE

TITLE:

SQBR-36X10-20W-AB-WA-DIM-WET-27K

DRAWN

CHECKED

ENG APPR.

MFG APPR.

Q.A.

COMMENTS:

**PROPRIETARY AND CONFIDENTIAL**

THE INFORMATION CONTAINED IN THIS  
 DRAWING IS THE SOLE PROPERTY OF  
 <INSERT COMPANY NAME HERE>. ANY  
 REPRODUCTION IN PART OR AS A WHOLE  
 WITHOUT THE WRITTEN PERMISSION OF  
 <INSERT COMPANY NAME HERE> IS  
 PROHIBITED.

NEXT ASSY	USED ON
APPLICATION	

SIZE  
**A**

DWG. NO.

REV

SCALE: 1:8

WEIGHT:

SHEET 7 OF 9

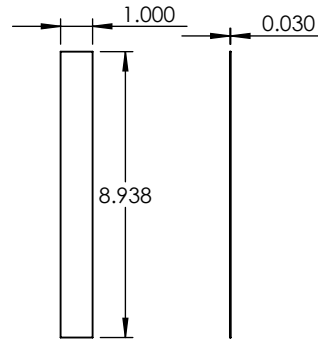
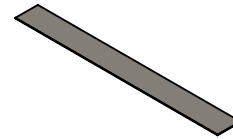
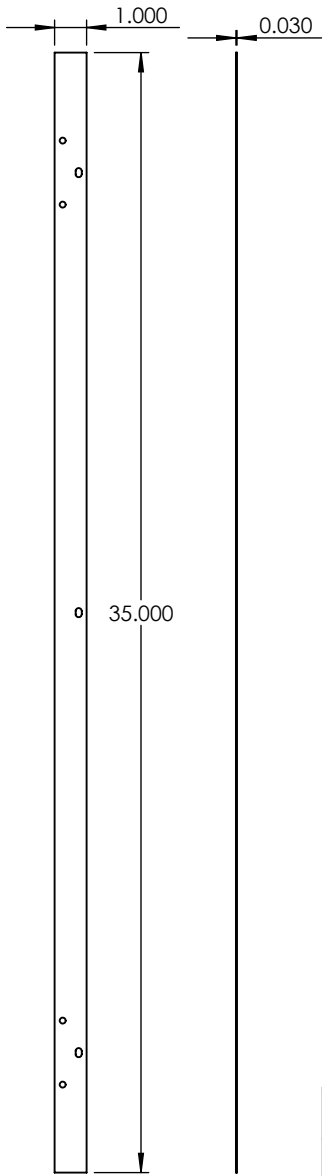

**PROPRIETARY AND CONFIDENTIAL**  
 THE INFORMATION CONTAINED IN THIS DRAWING IS THE SOLE PROPERTY OF <INSERT COMPANY NAME HERE>. ANY REPRODUCTION IN PART OR AS A WHOLE WITHOUT THE WRITTEN PERMISSION OF <INSERT COMPANY NAME HERE> IS PROHIBITED.

		UNLESS OTHERWISE SPECIFIED:		NAME	DATE	22 GAUGE		
		DIMENSIONS ARE IN INCHES TOLERANCES: FRACTIONAL ± ANGULAR: MACH ± BEND ± TWO PLACE DECIMAL ± THREE PLACE DECIMAL ±	DRAWN					TITLE:
		INTERPRET GEOMETRIC TOLERANCING PER:	CHECKED			SQBR-36X10-20W-AB-WA-DIM-WET-27K		
		MATERIAL	ENG APPR.					
		FINISH	MFG APPR.			SIZE	DWG. NO.	REV
NEXT ASSY	USED ON		Q.A.			<b>A</b>		
APPLICATION		DO NOT SCALE DRAWING	COMMENTS:				SCALE: 1:6	WEIGHT:



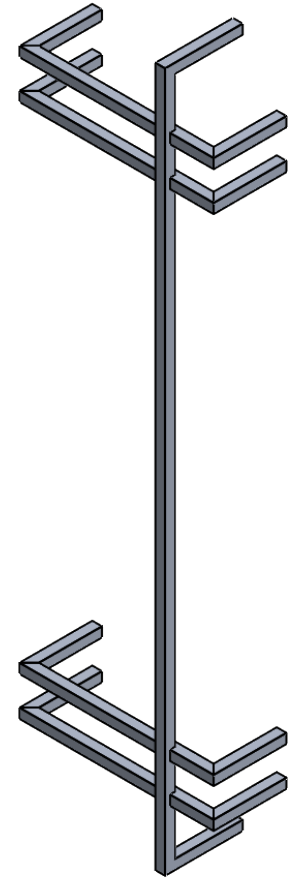
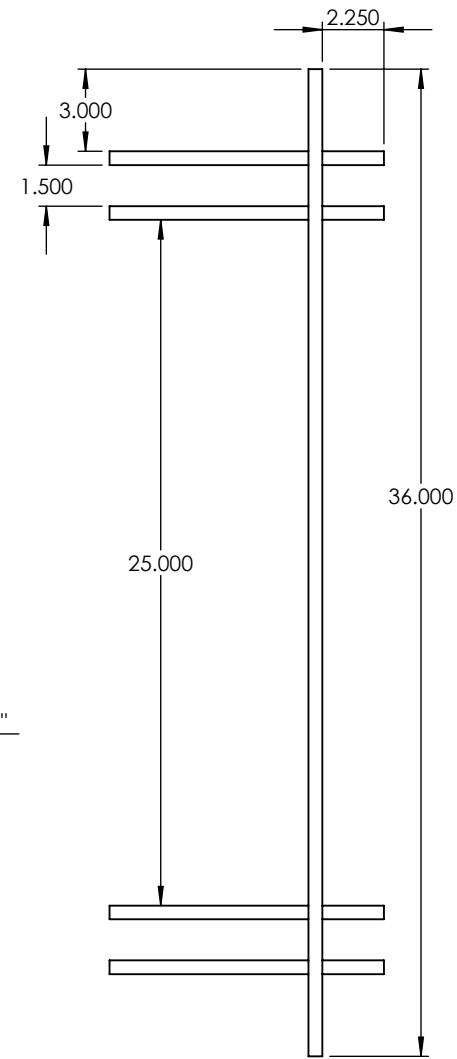
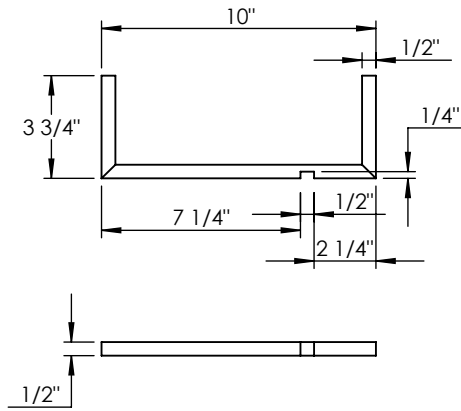
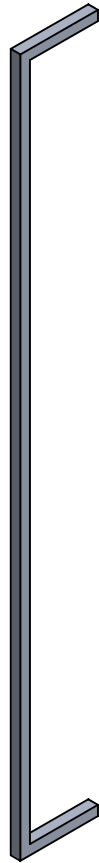
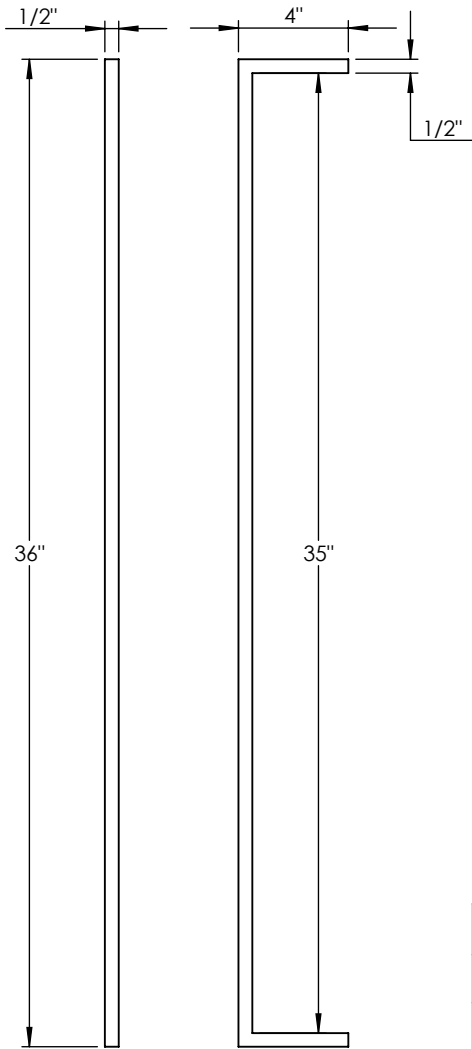

**PROPRIETARY AND CONFIDENTIAL**  
 THE INFORMATION CONTAINED IN THIS DRAWING IS THE SOLE PROPERTY OF <INSERT COMPANY NAME HERE>. ANY REPRODUCTION IN PART OR AS A WHOLE WITHOUT THE WRITTEN PERMISSION OF <INSERT COMPANY NAME HERE> IS PROHIBITED.

		UNLESS OTHERWISE SPECIFIED:	NAME	DATE	1/2" SQUARE ALUMINUM BAR	
		DIMENSIONS ARE IN INCHES	DRAWN		TITLE:	
		TOLERANCES:	CHECKED		SQBR-36X10-20W-AB-WA-DIM-WET-27K	
		FRACTIONAL ±	ENG APPR.		SIZE DWG. NO. REV	
		ANGULAR: MACH ± BEND ±	MFG APPR.		SCALE: 1:7 WEIGHT: SHEET 9 OF 9	
		TWO PLACE DECIMAL ±	Q.A.			
		THREE PLACE DECIMAL ±	COMMENTS:			
		INTERPRET GEOMETRIC TOLERANCING PER:				
		MATERIAL				
NEXT ASSY	USED ON	FINISH				
APPLICATION		DO NOT SCALE DRAWING				

5

4

3

2

1