

ITEM NO.	PART NUMBER	DESCRIPTION	QTY.	CUT
1	VSHP-PST-33"-60W-9-CA-DIM-30K-3" POST FITTER	3-1/2" ALUMINUM TUBE	1	
2	VSHP-PST-33"-60W-9-CA-DIM-30K-3" FITTER BRACKET	ALUMINUM 0.500" PLATE	1	
3	VSHP-PST-33"-60W-9-CA-DIM-30K-5" FITTER BRACKET	ALUMINUM 0.500" PLATE	1	
4	VSHP-PST-33"-60W-9-CA-DIM-30K-LED PLATE	ALUMINUM 0.250" PLATE	1	
5	VSHP-PST-33"-60W-9-CA-DIM-30K-END BRACKET	ALUMINUM 0.250" PLATE	2	
6	VSHP-PST-33"-60W-9-CA-DIM-30K-FRAME BAR PLATE	ALUMINUM 0.125" PLATE	1	
7	VSHP-PST-33"-60W-9-CA-DIM-30K-SPUN ACCENT	SPUN ALUMINUM 0.080"	1	
8	VSHP-PST-33"-60W-9-CA-DIM-30K-FRAME TUBE	3"X1-1/2" ALUMINUM TUBE	1	
9	VSHP-PST-33"-60W-9-CA-DIM-30K-ARM TUBE	3"X1-1/2" ALUMINUM TUBE	2	
10	VSHP-PST-33"-60W-9-CA-DIM-30K-FRAME BRACKET	ALUMINUM 0.0635"	1	
11	VSHP-PST-33"-60W-9-CA-DIM-30K-DRIVER BRACKET	ALUMINUM 0.0635"	1	
12	VSHP-PST-33"-60W-9-CA-DIM-30K-DRIVER EXTENSION	ALUMINUM 0.0635"	1	
13	VSHP-PST-33"-60W-9-CA-DIM-30K-ACRYLIC	ACRYLIC	1	
14	AltLED_PN110B_RevC	LED	4	
15	KTLD-25-UV-700-VDIM-LA1	DRIVER	2	

UNLESS OTHERWISE SPECIFIED:

DIMENSIONS ARE IN INCHES
 TOLERANCES:
 FRACTIONAL ± .003
 ANGULAR: MACH ± .01 BEND ±
 TWO PLACE DECIMAL ±
 THREE PLACE DECIMAL ±.001

INTERPRET GEOMETRIC
 TOLERANCING PER:

MATERIAL

FINISH

	NAME	DATE
DRAWN		
CHECKED		
ENG APPR.		
MFG APPR.		
Q.A.		

COMMENTS:

TITLE:

VSHP-PST-33"-60W-9-CA-DIM-30K

SIZE DWG. NO. REV

A TICKET 27330

SCALE: 1:11 WEIGHT: SHEET 1 OF 10

EVERGREEN LIGHTING

ALL BEND RADIUS .030"

APPLICATION

DO NOT SCALE DRAWING

5

4

3

2

1

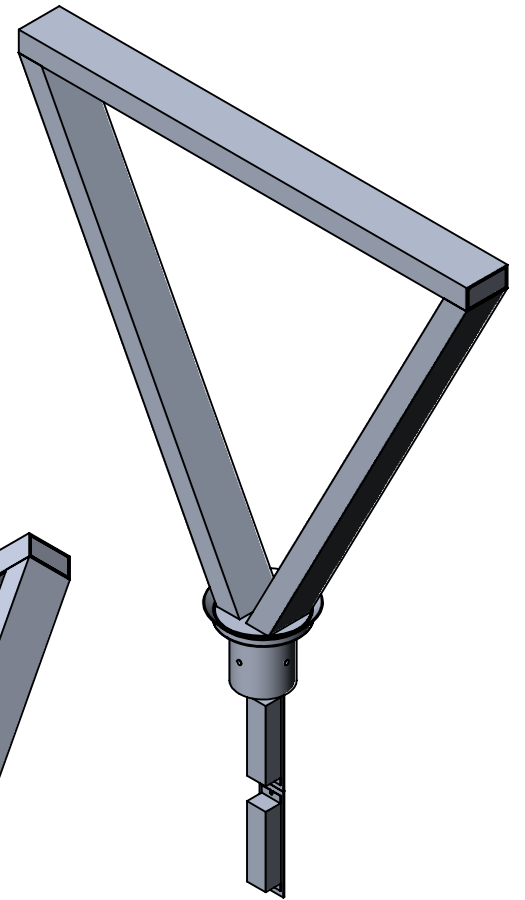
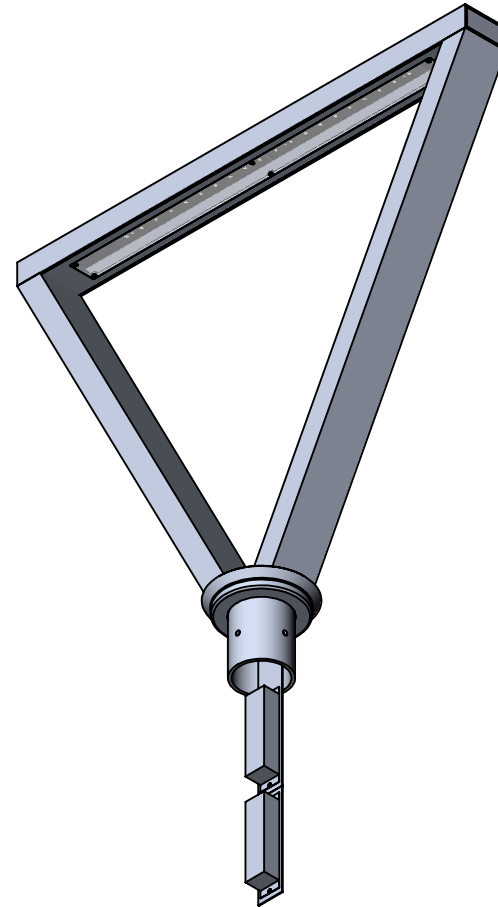
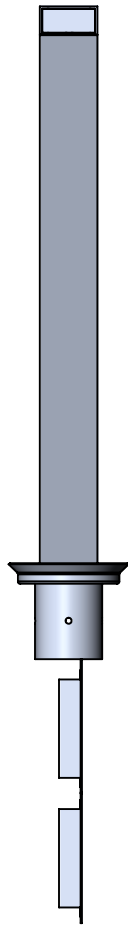
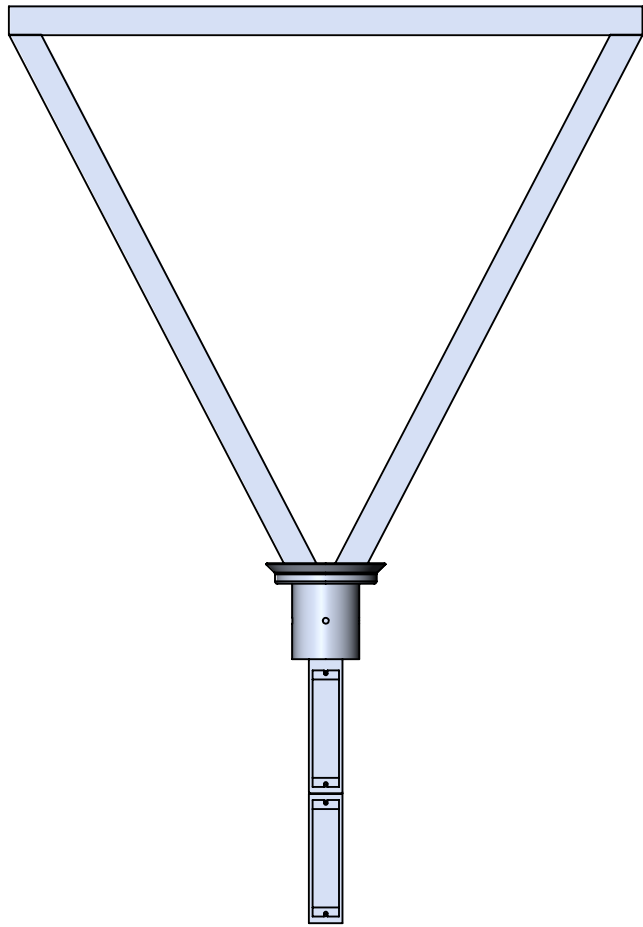

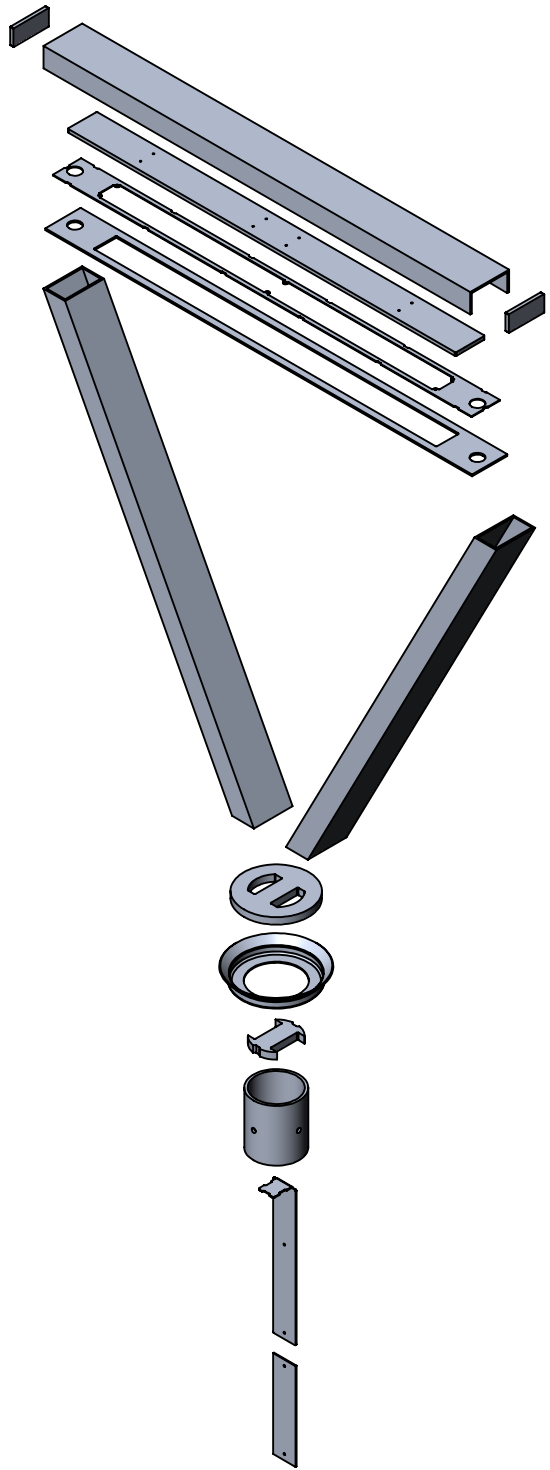

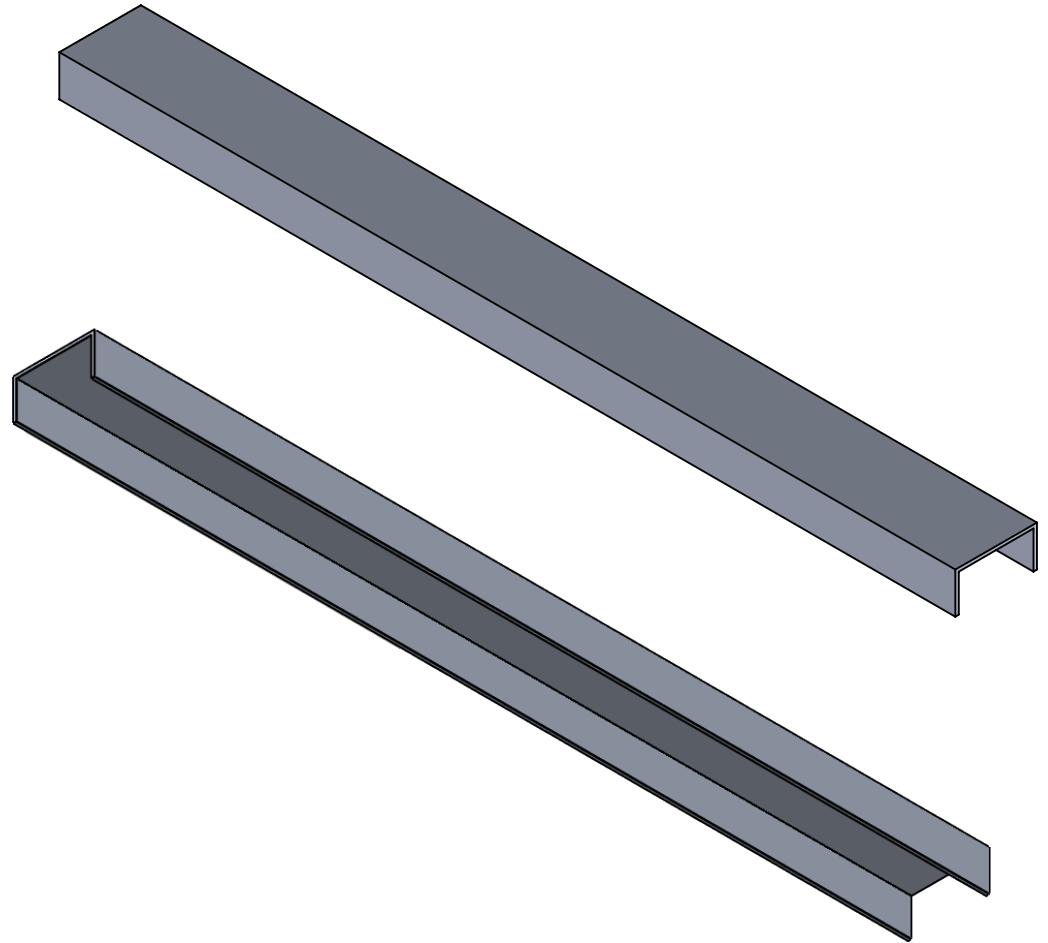
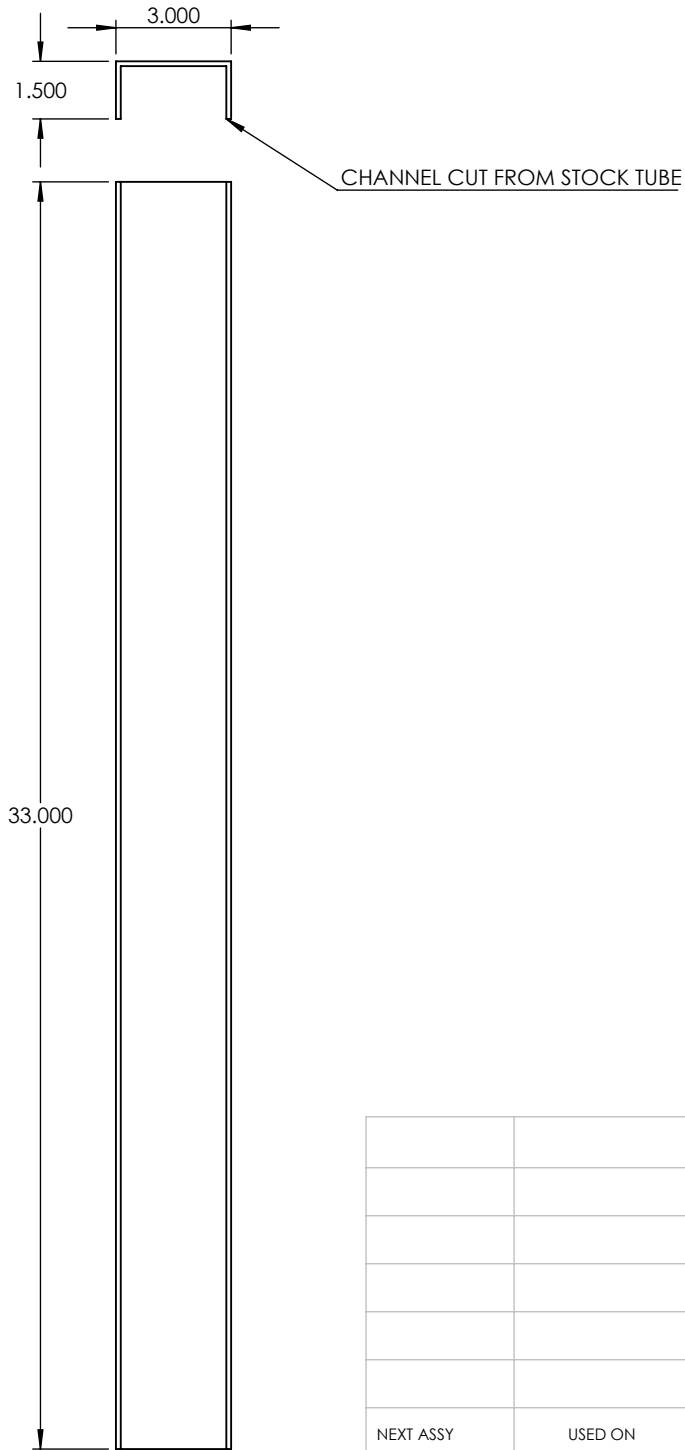

		UNLESS OTHERWISE SPECIFIED:	NAME	DATE	3"X1-1/2" ALUMINUM TUBE	
		DIMENSIONS ARE IN INCHES	DRAWN		TITLE:	
		TOLERANCES:	CHECKED		VSHP-PST-33"-60W-9-CA-DIM-30K	
		FRACTIONAL ±	ENG APPR.		SIZE	DWG. NO.
		ANGULAR: MACH ± BEND ±	MFG APPR.		A	REV
		TWO PLACE DECIMAL ±	Q.A.		SCALE: 1:5	WEIGHT:
		THREE PLACE DECIMAL ±	COMMENTS:			SHEET 4 OF 10
		INTERPRET GEOMETRIC TOLERANCING PER:				
		MATERIAL				
NEXT ASSY	USED ON	FINISH				
APPLICATION		DO NOT SCALE DRAWING				

5

4

3

2

1

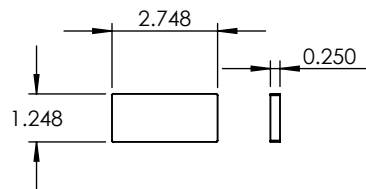
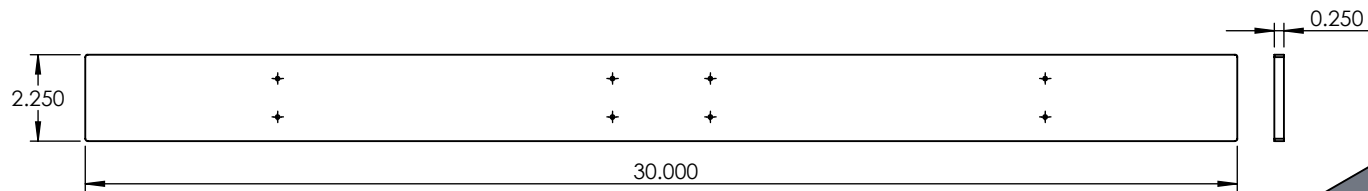
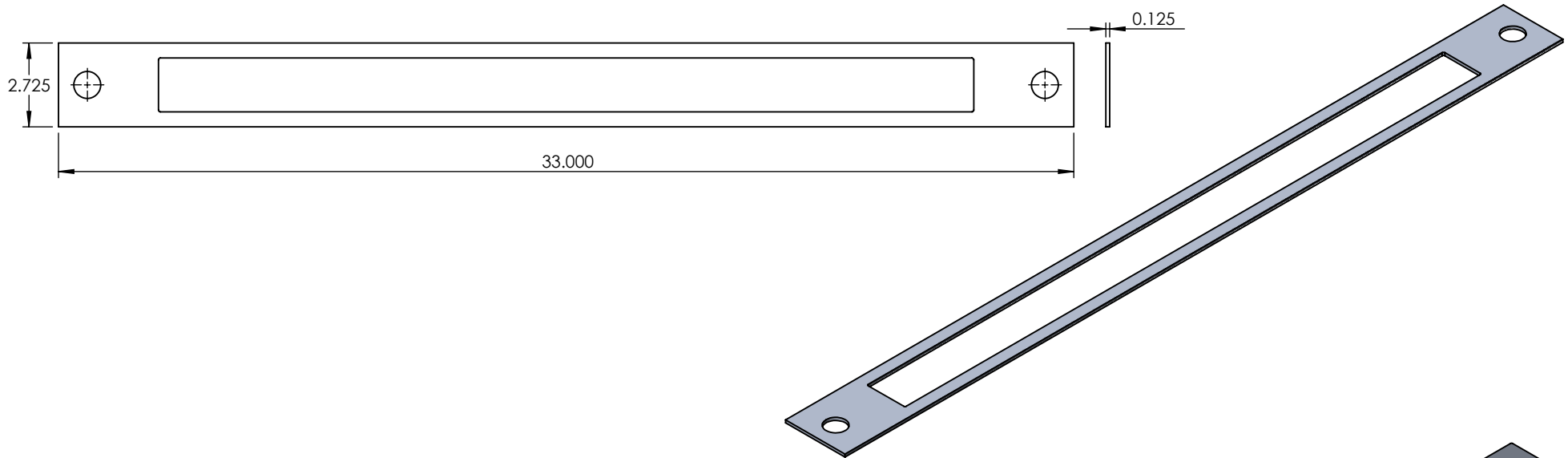

UNLESS OTHERWISE SPECIFIED:

DIMENSIONS ARE IN INCHES
 TOLERANCES:
 FRACTIONAL ±
 ANGULAR: MACH ± BEND ±
 TWO PLACE DECIMAL ±
 THREE PLACE DECIMAL ±

INTERPRET GEOMETRIC
 TOLERANCING PER:

MATERIAL

FINISH

DO NOT SCALE DRAWING

NAME DATE

DRAWN

CHECKED

ENG APPR.

MFG APPR.

Q.A.

COMMENTS:

ALUMINUM 0.250" PLATE

TITLE:

VSHP-PST-33"-60W-9-CA-DIM-30K

SIZE
A

DWG. NO.

REV

SCALE: 1:5

WEIGHT:

SHEET 5 OF 10

PROPRIETARY AND CONFIDENTIAL
 THE INFORMATION CONTAINED IN THIS
 DRAWING IS THE SOLE PROPERTY OF
 <INSERT COMPANY NAME HERE>. ANY
 REPRODUCTION IN PART OR AS A WHOLE
 WITHOUT THE WRITTEN PERMISSION OF
 <INSERT COMPANY NAME HERE> IS
 PROHIBITED.

NEXT ASSY

USED ON

APPLICATION

5

4

3

2

1

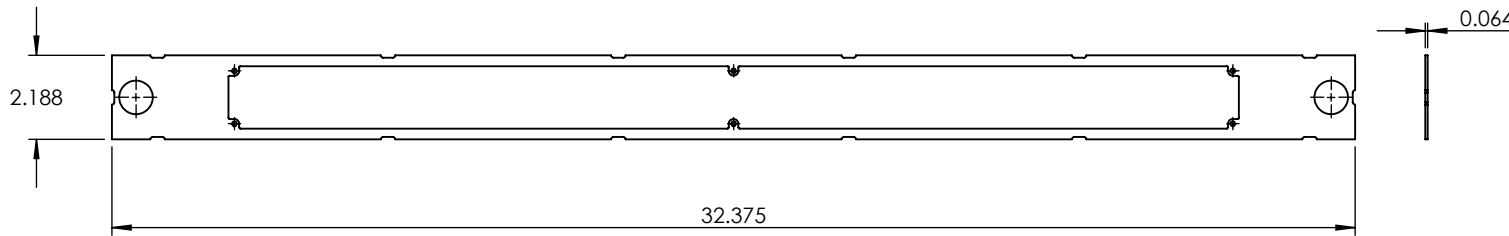
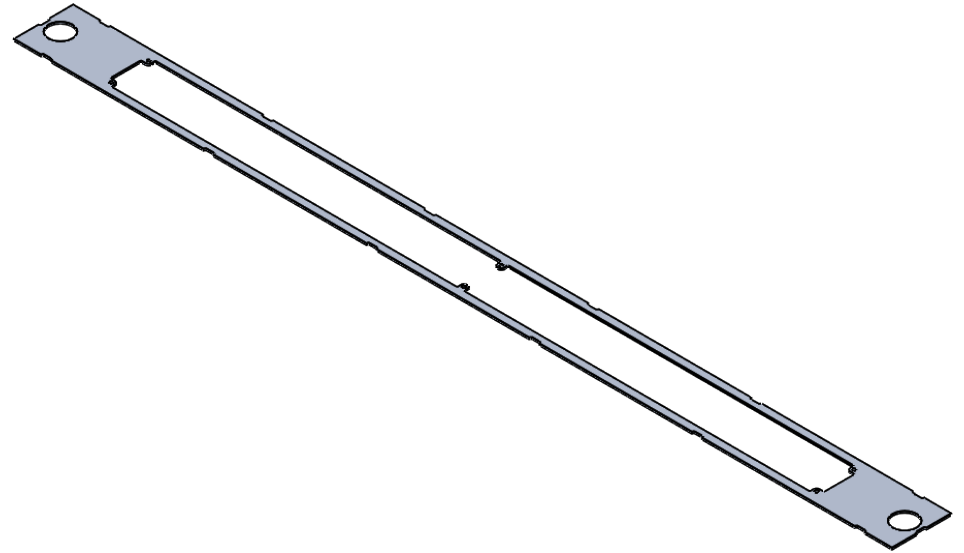

PROPRIETARY AND CONFIDENTIAL
 THE INFORMATION CONTAINED IN THIS DRAWING IS THE SOLE PROPERTY OF <INSERT COMPANY NAME HERE>. ANY REPRODUCTION IN PART OR AS A WHOLE WITHOUT THE WRITTEN PERMISSION OF <INSERT COMPANY NAME HERE> IS PROHIBITED.

		UNLESS OTHERWISE SPECIFIED:		NAME	DATE
		DIMENSIONS ARE IN INCHES	DRAWN		
		TOLERANCES:	CHECKED		
		FRACTIONAL ±	ENG APPR.		
		ANGULAR: MACH ± BEND ±	MFG APPR.		
		TWO PLACE DECIMAL ±	Q.A.		
		THREE PLACE DECIMAL ±	COMMENTS:		
		INTERPRET GEOMETRIC TOLERANCING PER:			
		MATERIAL			
		FINISH			
NEXT ASSY	USED ON				
APPLICATION		DO NOT SCALE DRAWING			

ALUMINUM 0.0635"		
TITLE:		
VSHP-PST-33"-60W-9-CA-DIM-30K		
SIZE	DWG. NO.	REV
A		
SCALE: 1:5	WEIGHT:	SHEET 6 OF 10

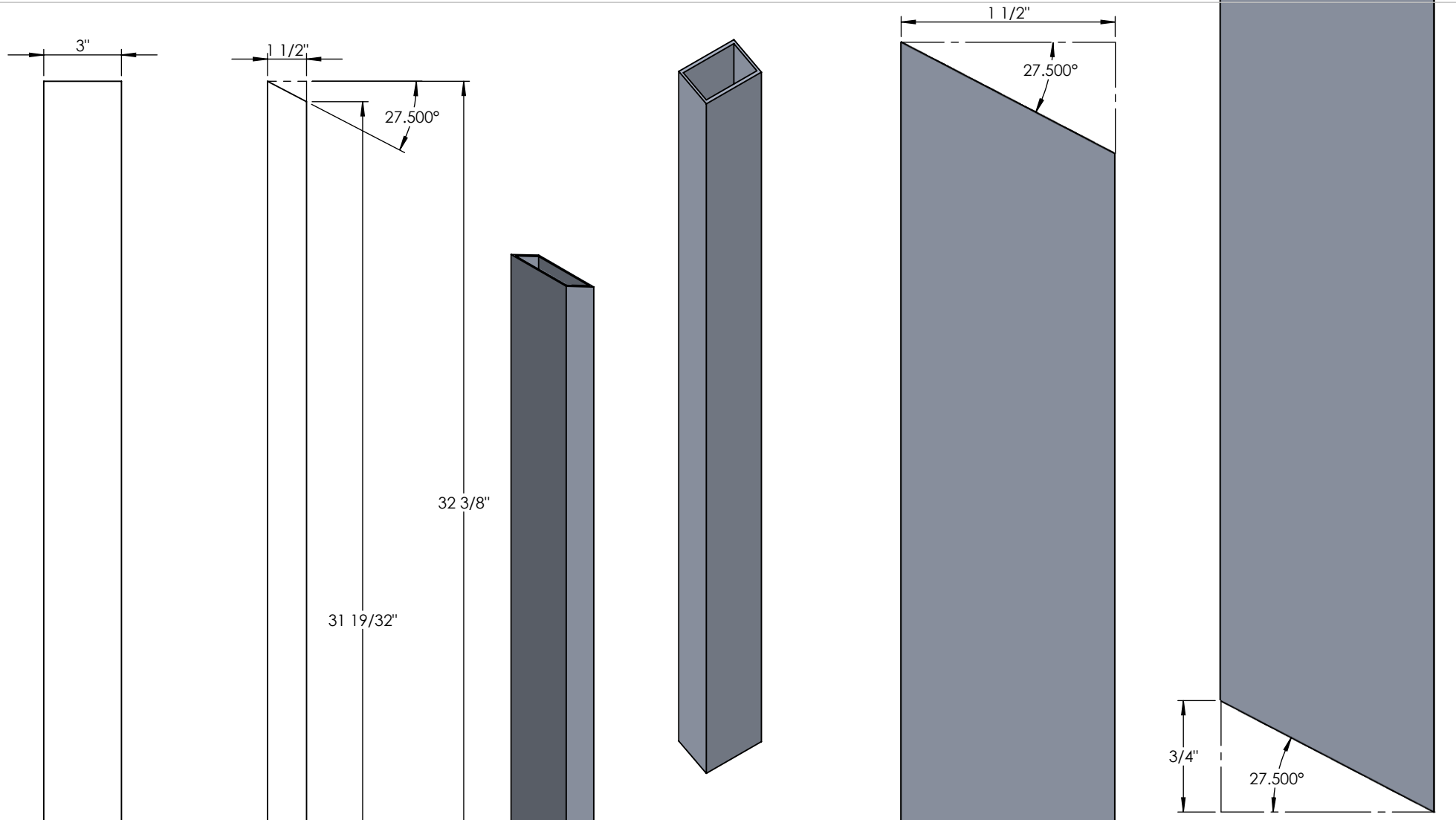

UNLESS OTHERWISE SPECIFIED:

DIMENSIONS ARE IN INCHES
 TOLERANCES:
 FRACTIONAL ±
 ANGULAR: MACH ± BEND ±
 TWO PLACE DECIMAL ±
 THREE PLACE DECIMAL ±

INTERPRET GEOMETRIC TOLERANCING PER:

MATERIAL

FINISH

DO NOT SCALE DRAWING

	NAME	DATE
DRAWN		
CHECKED		
ENG APPR.		
MFG APPR.		
Q.A.		
COMMENTS		

TITLE: 3"X1-1/2" ALUMINUM TUBE

VS-HP-PST-33"-60W-9-CA-DIM-30K

SIZE DWG. NO. REV

A

SCALE: 1:5.5 WEIGHT: SHEET 7 OF 10

PROPRIETARY AND CONFIDENTIAL
 THE INFORMATION CONTAINED IN THIS DRAWING IS THE SOLE PROPERTY OF <INSERT COMPANY NAME HERE>. ANY REPRODUCTION IN PART OR AS A WHOLE WITHOUT THE WRITTEN PERMISSION OF <INSERT COMPANY NAME HERE> IS PROHIBITED.

NEXT ASSY	USED ON
APPLICATION	DO NOT SCALE DRAWING

ITEM NO.	PART NUMBER	DESCRIPTION	QTY.
1	VSHP-PST-33"-60W-9-CA-DIM-30K-SPUN ACCENT	SPUN ALUMINUM 0.080"	1

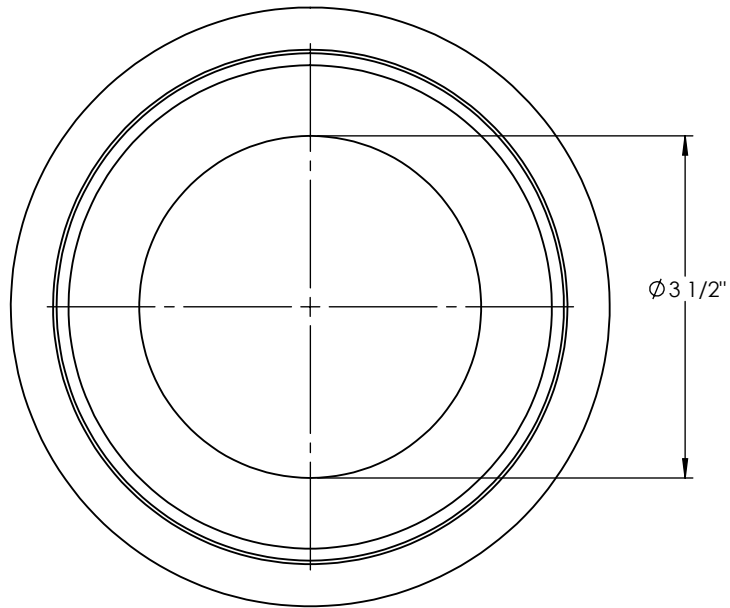
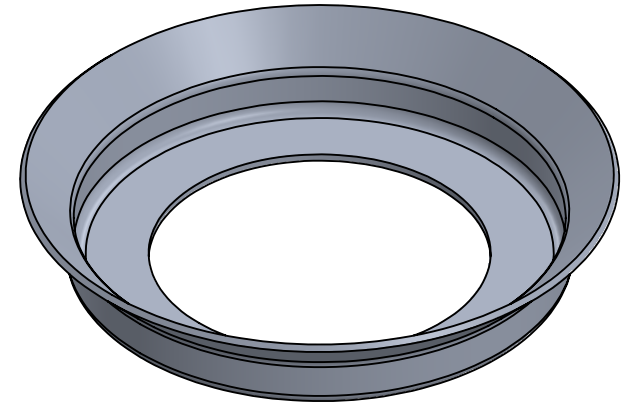
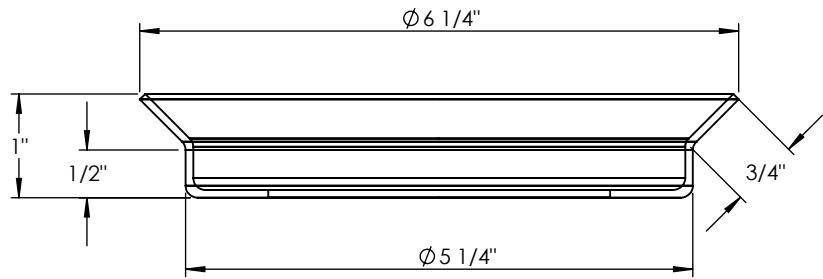

PROPRIETARY AND CONFIDENTIAL
 THE INFORMATION CONTAINED IN THIS DRAWING IS THE SOLE PROPERTY OF <INSERT COMPANY NAME HERE>. ANY REPRODUCTION IN PART OR AS A WHOLE WITHOUT THE WRITTEN PERMISSION OF <INSERT COMPANY NAME HERE> IS PROHIBITED.

		UNLESS OTHERWISE SPECIFIED:	NAME	DATE	SPUN ALUMINUM 0.080"	
		DIMENSIONS ARE IN INCHES TOLERANCES: FRACTIONAL ± ANGULAR: MACH ± BEND ± TWO PLACE DECIMAL ± THREE PLACE DECIMAL ±	DRAWN			
		INTERPRET GEOMETRIC TOLERANCING PER:	CHECKED		VSHP-PST-33"-60W-9-CA-DIM-30K	
		MATERIAL	ENG APPR.			
		FINISH	MFG APPR.		SIZE	DWG. NO.
NEXT ASSY	USED ON		Q.A.		A	REV
APPLICATION		DO NOT SCALE DRAWING	COMMENTS:		SCALE: 1:2	WEIGHT:
					SHEET 8 OF 10	

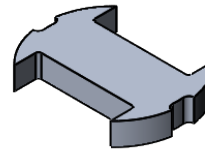
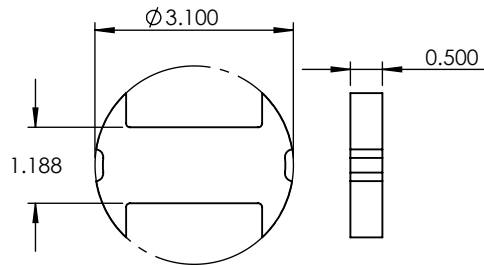
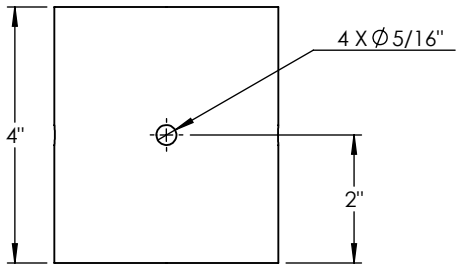
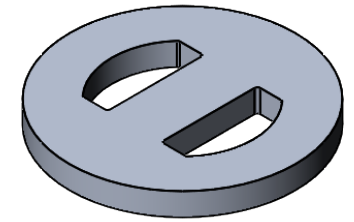
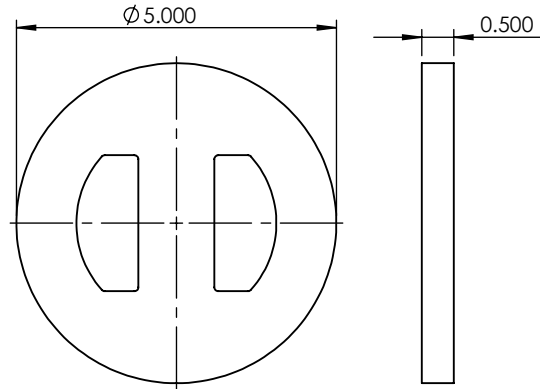
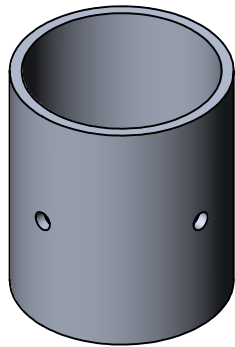
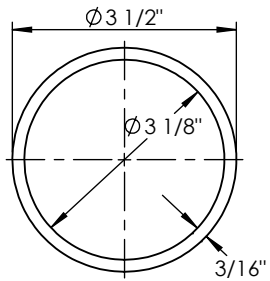

PROPRIETARY AND CONFIDENTIAL
 THE INFORMATION CONTAINED IN THIS DRAWING IS THE SOLE PROPERTY OF <INSERT COMPANY NAME HERE>. ANY REPRODUCTION IN PART OR AS A WHOLE WITHOUT THE WRITTEN PERMISSION OF <INSERT COMPANY NAME HERE> IS PROHIBITED.

		UNLESS OTHERWISE SPECIFIED:	NAME	DATE
		DIMENSIONS ARE IN INCHES	DRAWN	
		TOLERANCES:	CHECKED	
		FRACTIONAL ±	ENG APPR.	
		ANGULAR: MACH ± BEND ±	MFG APPR.	
		TWO PLACE DECIMAL ±	Q.A.	
		THREE PLACE DECIMAL ±	COMMENTS:	
		INTERPRET GEOMETRIC TOLERANCING PER:		
		MATERIAL		
		FINISH		
NEXT ASSY	USED ON			
APPLICATION		DO NOT SCALE DRAWING		

3-1/2" ALUMINUM TUBE		
TITLE:		
VSHP-PST-33"-60W-9-CA-DIM-30K		
SIZE	DWG. NO.	REV
A		
SCALE: 1:3	WEIGHT:	SHEET 9 OF 10

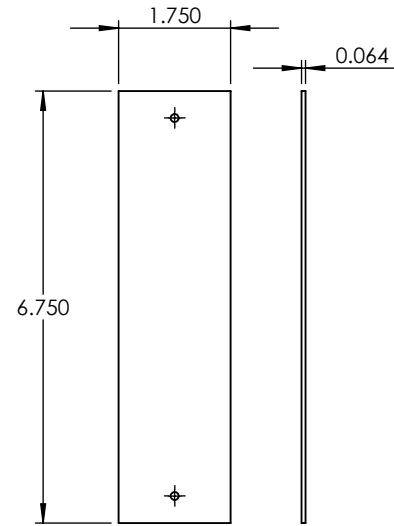
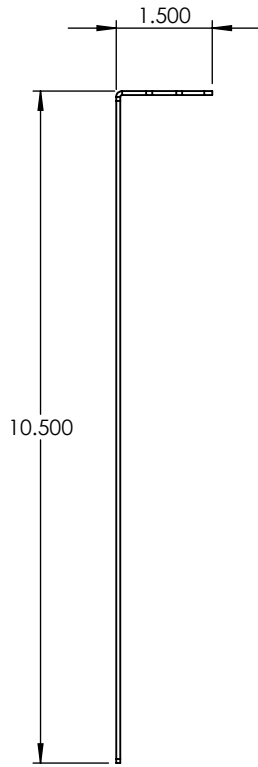
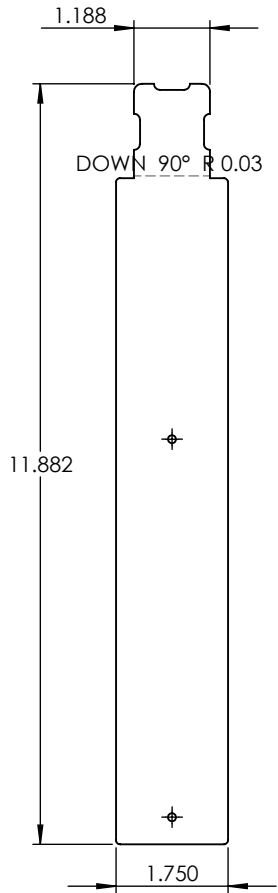

PROPRIETARY AND CONFIDENTIAL
 THE INFORMATION CONTAINED IN THIS DRAWING IS THE SOLE PROPERTY OF <INSERT COMPANY NAME HERE>. ANY REPRODUCTION IN PART OR AS A WHOLE WITHOUT THE WRITTEN PERMISSION OF <INSERT COMPANY NAME HERE> IS PROHIBITED.

		UNLESS OTHERWISE SPECIFIED:	NAME	DATE	ALUMINUM 0.0635"	
		DIMENSIONS ARE IN INCHES	DRAWN		TITLE:	
		TOLERANCES:	CHECKED		VSHP-PST-33"-60W-9-CA-DIM-30K	
		FRACTIONAL ±	ENG APPR.		SIZE	DWG. NO.
		ANGULAR: MACH ± BEND ±	MFG APPR.		A	REV
		TWO PLACE DECIMAL ±	Q.A.		SCALE: 1:3	WEIGHT:
		THREE PLACE DECIMAL ±	COMMENTS:			SHEET 10 OF 10
		INTERPRET GEOMETRIC TOLERANCING PER:				
		MATERIAL				
	NEXT ASSY	FINISH				
	USED ON					
	APPLICATION	DO NOT SCALE DRAWING				