

ITEM NO.	PART NUMBER	DESCRIPTION	QTY.	CUT
1	CYLSQ-ARM-30W-UD-18X6-MN-CFA-40K-CANOPY	22 GAUGE	1	
2	CYLSQ-ARM-30W-UD-18X6-MN-CFA-40K-FIREPLATE	22 GAUGE	1	
3	CYLSQ-ARM-30W-UD-18X6-MN-CFA-40K-CANOPY TAB	22 GAUGE	4	
4	CYLSQ-ARM-30W-UD-18X6-MN-CFA-40K-SPACER	22 GAUGE	1	
5	CYLSQ-ARM-30W-UD-18X6-MN-CFA-40K-FRAME BACKSIDE	22 GAUGE	1	
6	CYLSQ-ARM-30W-UD-18X6-MN-CFA-40K-BACKSIDE BRACKET	22 GAUGE	2	
7	CYLSQ-ARM-30W-UD-18X6-MN-CFA-40K-FRAME	22 GAUGE	1	
8	CYLSQ-ARM-30W-UD-18X6-MN-CFA-40K-TOP DOOR BRACKET	22 GAUGE	2	
9	CYLSQ-ARM-30W-UD-18X6-MN-CFA-40K-DOOR	22 GAUGE	2	
10	CYLSQ-ARM-30W-UD-18X6-MN-CFA-40K-CYLINDER BRACKET	ALUMINUM 0.0635"	1	
11	CYLSQ-ARM-30W-UD-18X6-MN-CFA-40K-ACRYLIC	ACRYLIC	2	
12	SMALL NUT	STEEL NUT	6	
13	Altal_LED_PN1019_SHIM PLATE	ALUMINUM 0.125" PLATE	4	
14	NIPPLE	NIPPLE	3	
15	ESPEN VEL29070MVH-1	DRIVER	2	
16	Altal_LED_PN1019_RevC	LED	4	

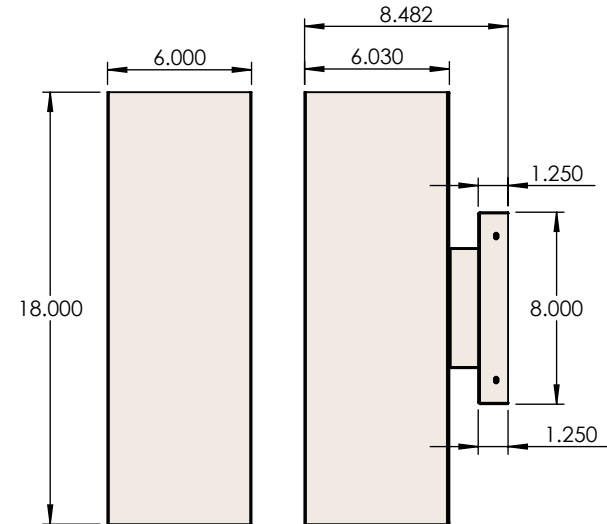
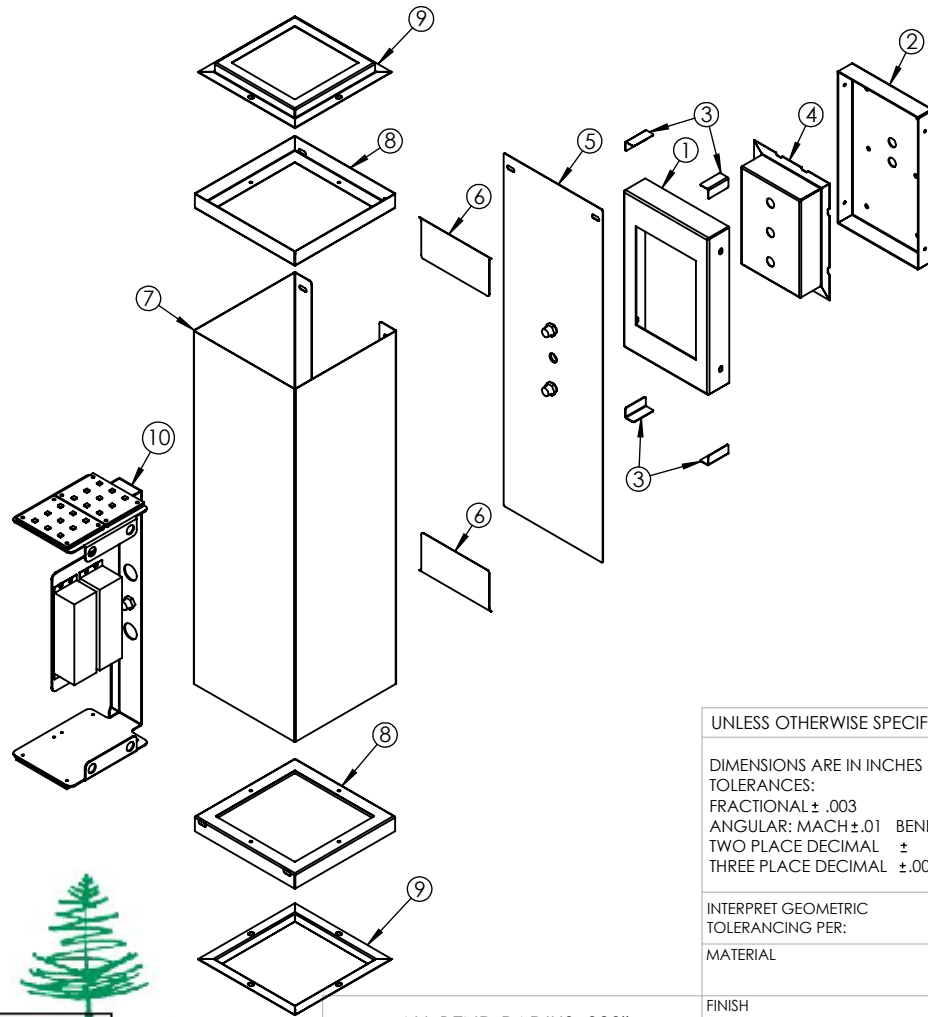
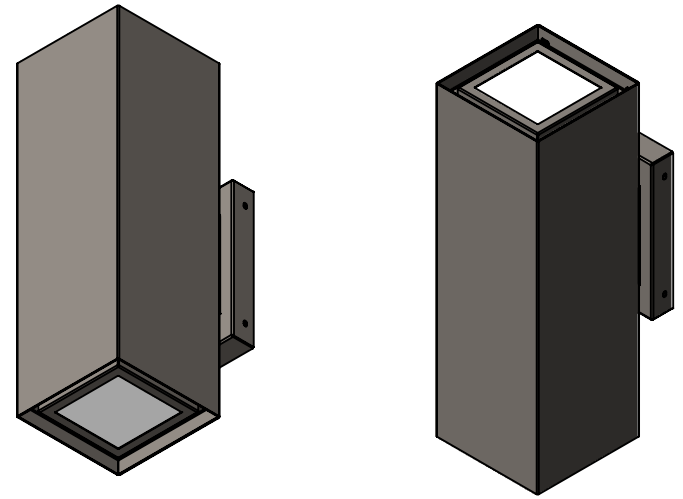

ALL BEND RADIUS .030"

UNLESS OTHERWISE SPECIFIED:	NAME	DATE	TITLE:	
DIMENSIONS ARE IN INCHES	DRAWN		CYLSQ-ARM-30W-UD-18X6-MN-CFA-40K	
TOLERANCES:	CHECKED			
FRACTIONAL ± .003	ENG APPR.			
ANGULAR: MACH ± .01 BEND ±	MFG APPR.			
TWO PLACE DECIMAL ±	Q.A.		SIZE	DWG. NO.
THREE PLACE DECIMAL ± .001	COMMENTS:		A	TICKET 27353
INTERPRET GEOMETRIC TOLERANCING PER:			SCALE: 1:8	WEIGHT:
MATERIAL				SHEET 1 OF 9
FINISH				

5

4

3

2

1

APPLICATION

DO NOT SCALE DRAWING

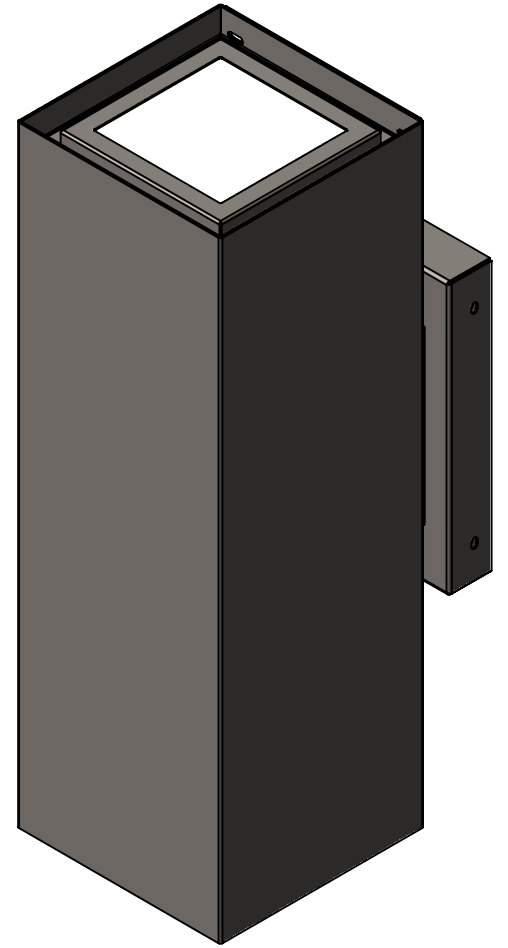
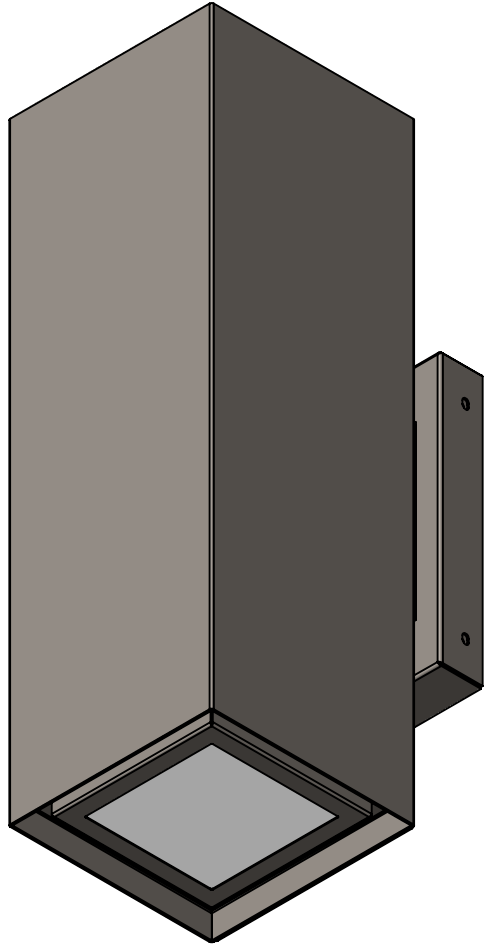
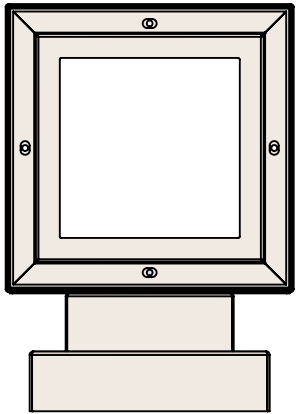
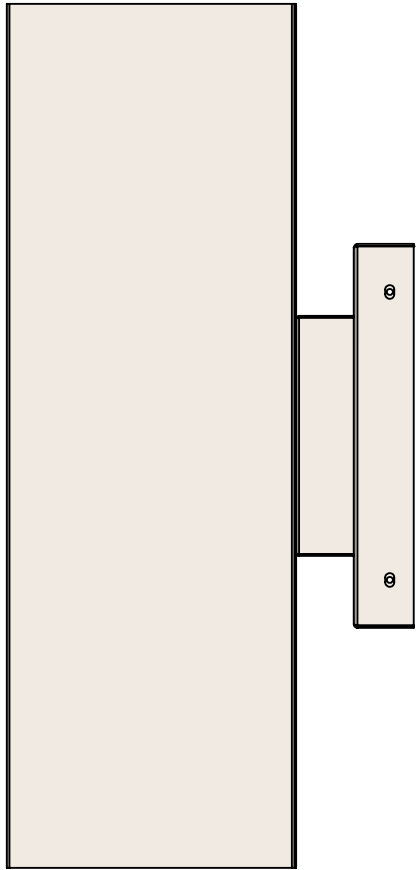
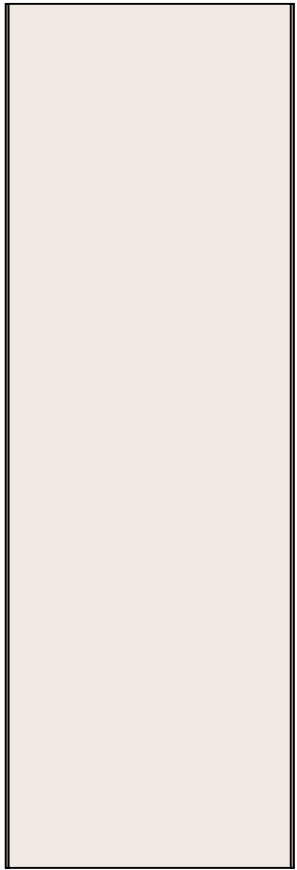

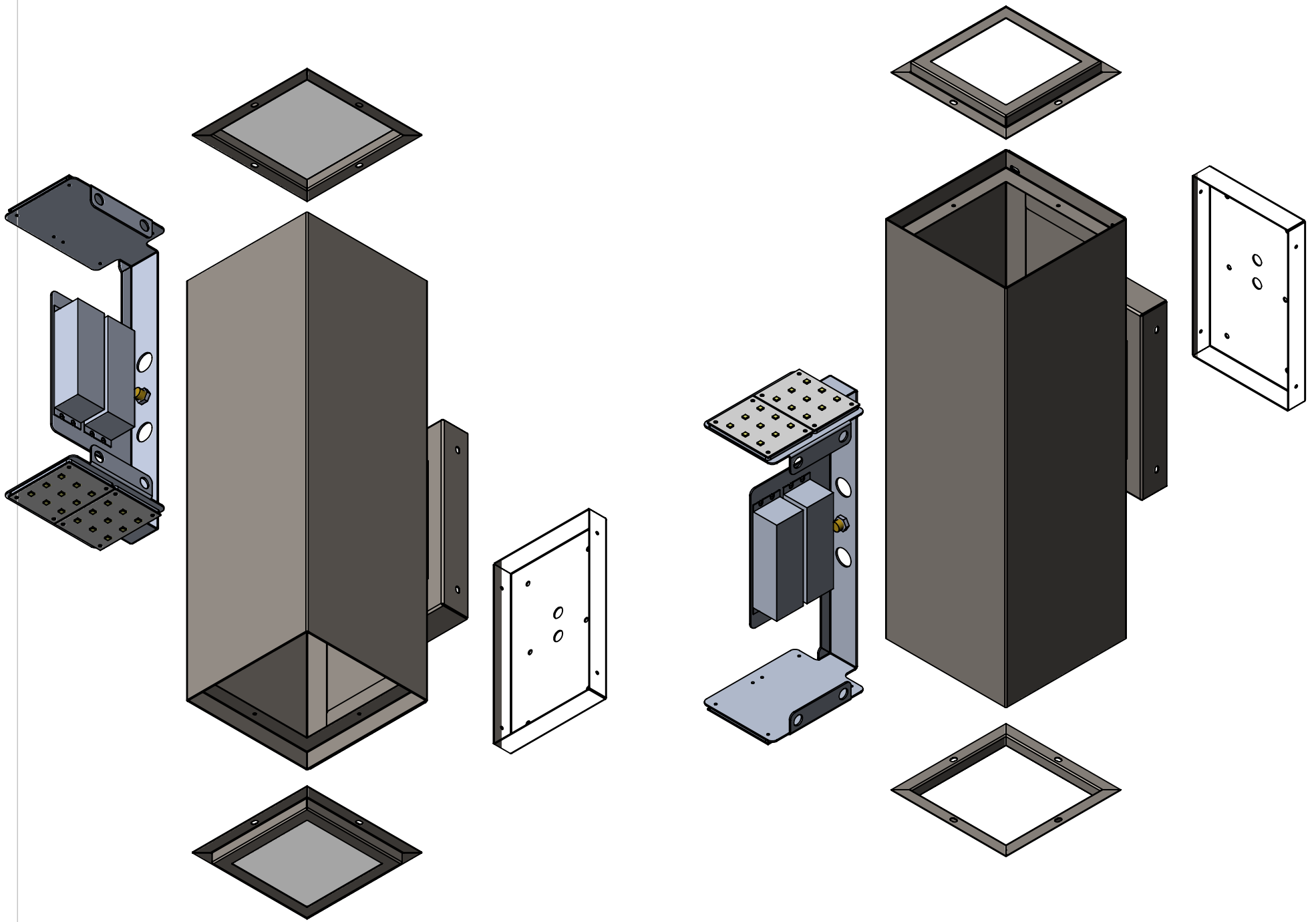

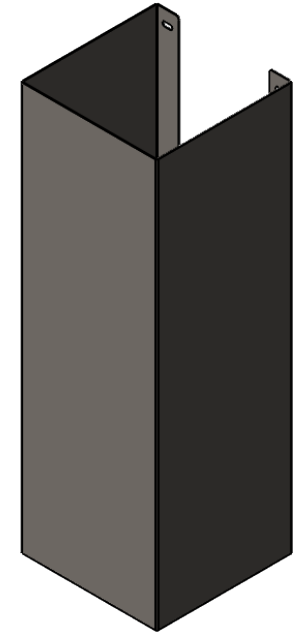
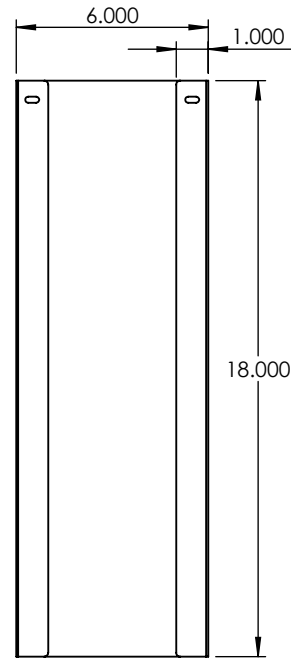
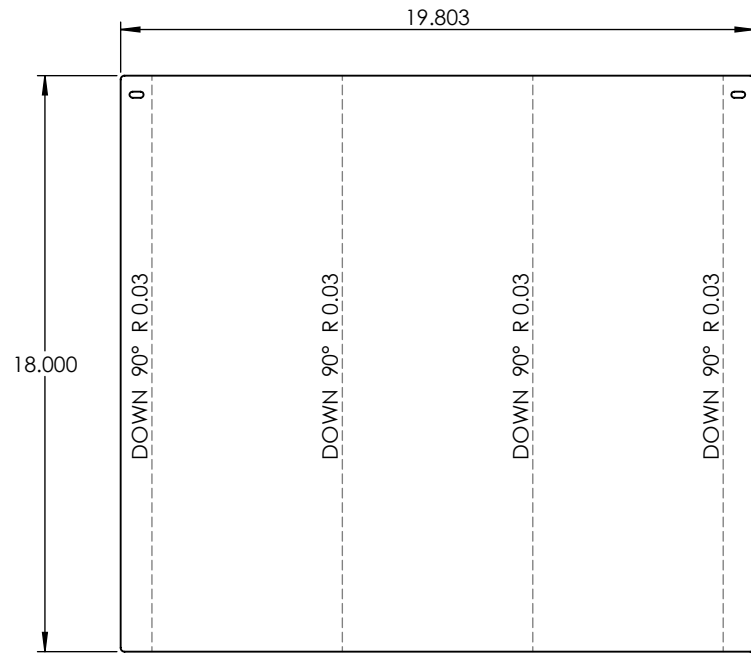
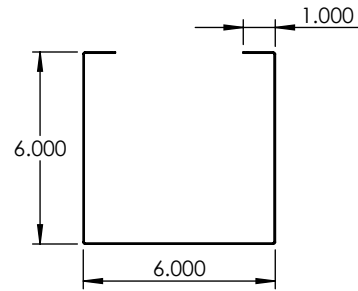

PROPRIETARY AND CONFIDENTIAL
 THE INFORMATION CONTAINED IN THIS DRAWING IS THE SOLE PROPERTY OF <INSERT COMPANY NAME HERE>. ANY REPRODUCTION IN PART OR AS A WHOLE WITHOUT THE WRITTEN PERMISSION OF <INSERT COMPANY NAME HERE> IS PROHIBITED.

		UNLESS OTHERWISE SPECIFIED:	NAME	DATE	22 GAUGE	
		DIMENSIONS ARE IN INCHES TOLERANCES: FRACTIONAL ± ANGULAR: MACH ± BEND ± TWO PLACE DECIMAL ± THREE PLACE DECIMAL ±	DRAWN			
		INTERPRET GEOMETRIC TOLERANCING PER:	CHECKED		SIZE DWG. NO. REV	
		MATERIAL	ENG APPR.			
		FINISH	MFG APPR.			
NEXT ASSY	USED ON		Q.A.			
APPLICATION		DO NOT SCALE DRAWING	COMMENTS:			

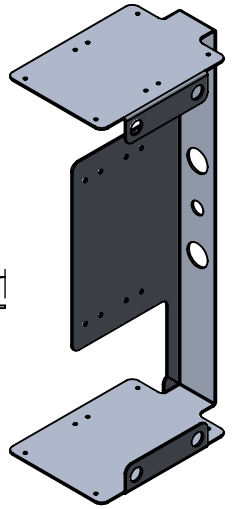
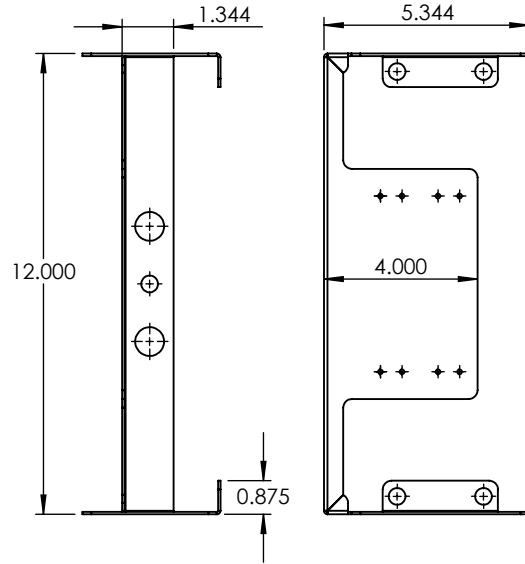
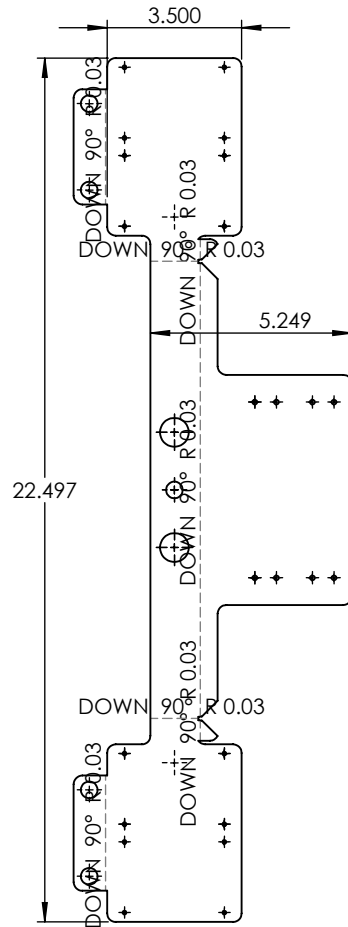
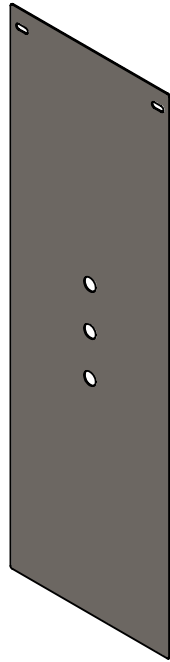
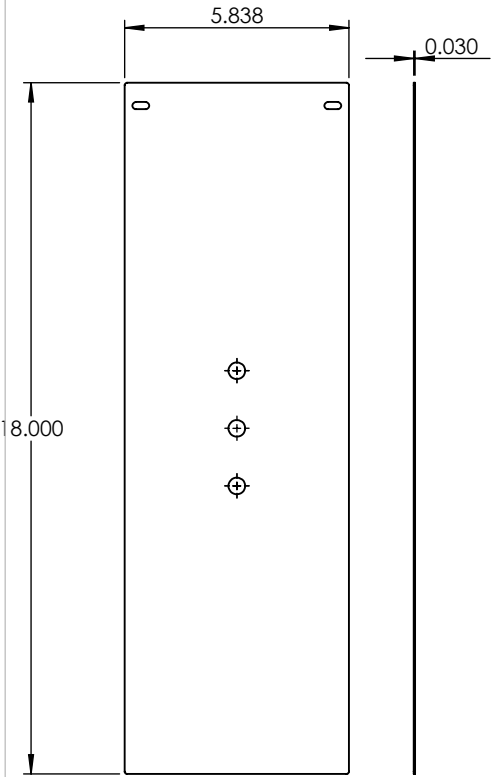
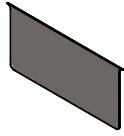
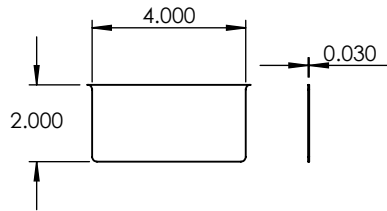

PROPRIETARY AND CONFIDENTIAL
 THE INFORMATION CONTAINED IN THIS DRAWING IS THE SOLE PROPERTY OF <INSERT COMPANY NAME HERE>. ANY REPRODUCTION IN PART OR AS A WHOLE WITHOUT THE WRITTEN PERMISSION OF <INSERT COMPANY NAME HERE> IS PROHIBITED.

		UNLESS OTHERWISE SPECIFIED:		NAME	DATE	22 GAUGE	
		DIMENSIONS ARE IN INCHES TOLERANCES: FRACTIONAL ± ANGULAR: MACH ± BEND ± TWO PLACE DECIMAL ± THREE PLACE DECIMAL ±		DRAWN		TITLE:	
		INTERPRET GEOMETRIC TOLERANCING PER:		CHECKED		CYLSQ-ARM-30W-UD-18X6-MN-CFA-40K	
		MATERIAL		ENG APPR.		SIZE DWG. NO.	
		FINISH		MFG APPR.		REV	
NEXT ASSY	USED ON			Q.A.		SCALE: 1:5 WEIGHT:	
APPLICATION		DO NOT SCALE DRAWING		COMMENTS:		SHEET 5 OF 9	

5

4

3

2

1

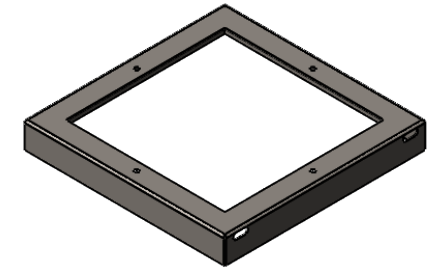
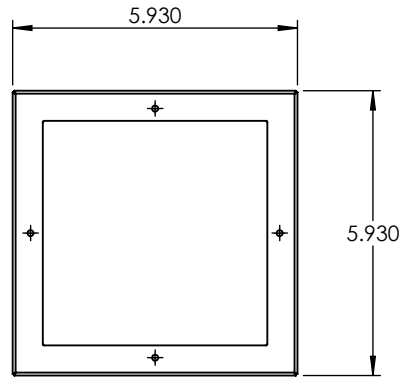
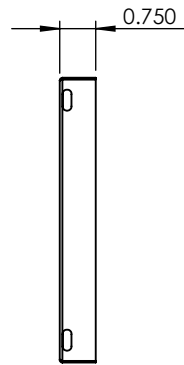
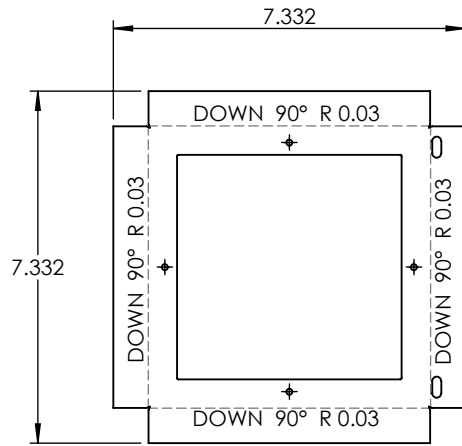
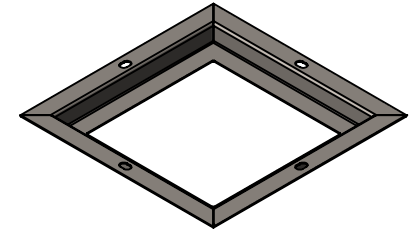
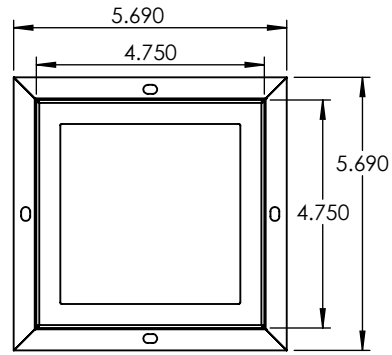
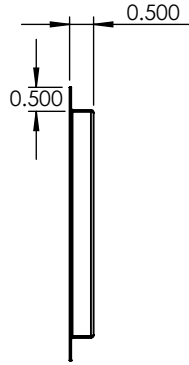
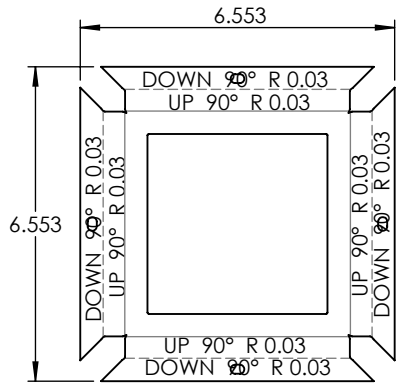

PROPRIETARY AND CONFIDENTIAL
 THE INFORMATION CONTAINED IN THIS DRAWING IS THE SOLE PROPERTY OF <INSERT COMPANY NAME HERE>. ANY REPRODUCTION IN PART OR AS A WHOLE WITHOUT THE WRITTEN PERMISSION OF <INSERT COMPANY NAME HERE> IS PROHIBITED.

		UNLESS OTHERWISE SPECIFIED:	NAME	DATE	22 GAUGE	
		DIMENSIONS ARE IN INCHES TOLERANCES: FRACTIONAL ± ANGULAR: MACH ± BEND ± TWO PLACE DECIMAL ± THREE PLACE DECIMAL ±	DRAWN			
		INTERPRET GEOMETRIC TOLERANCING PER:	CHECKED		SIZE DWG. NO. REV	
		MATERIAL	ENG APPR.			
		FINISH	MFG APPR.			
NEXT ASSY	USED ON		Q.A.			
APPLICATION		DO NOT SCALE DRAWING	COMMENTS:			

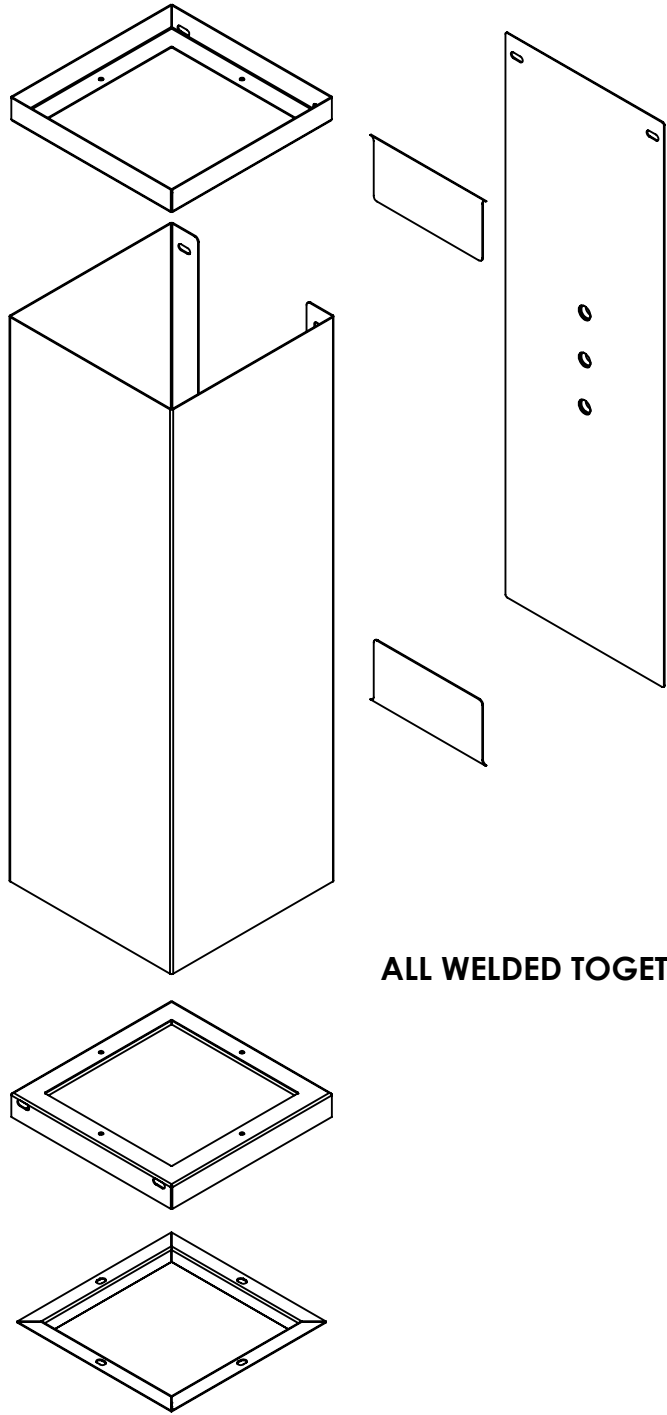

ALL WELDED TOGETHER

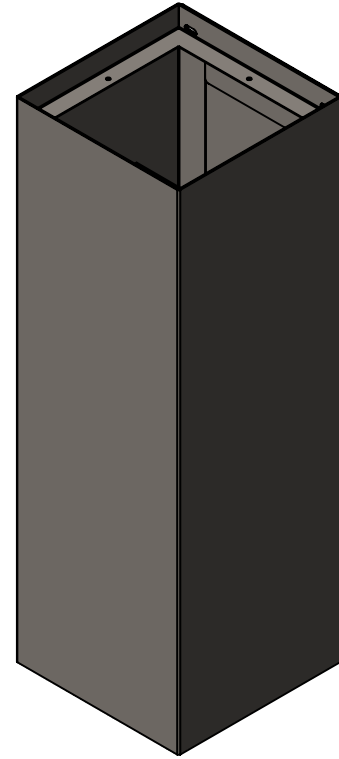

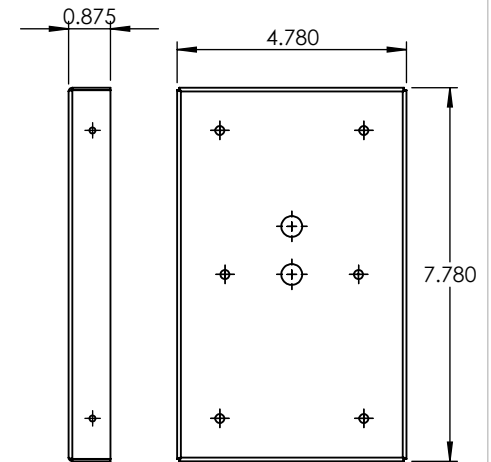
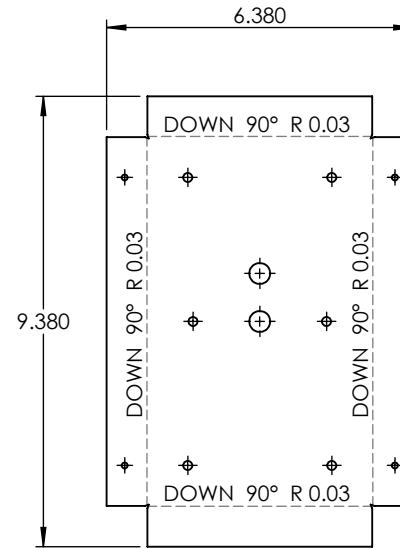
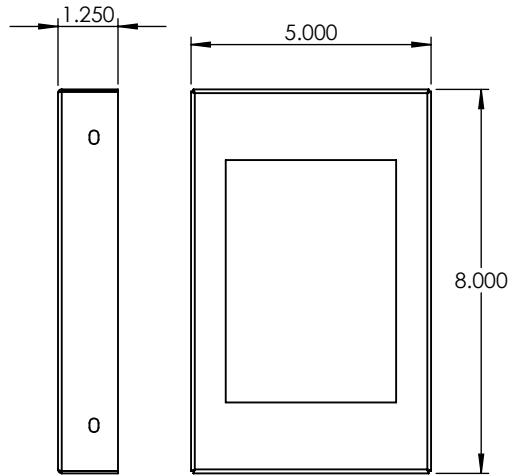
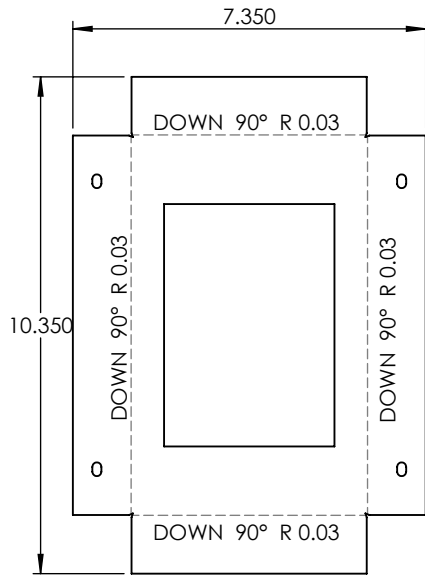
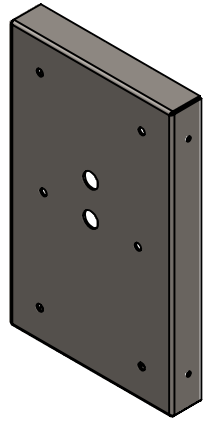
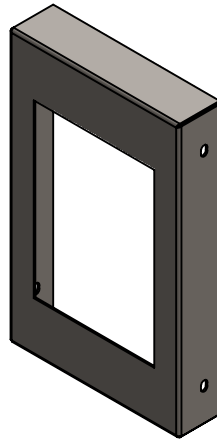
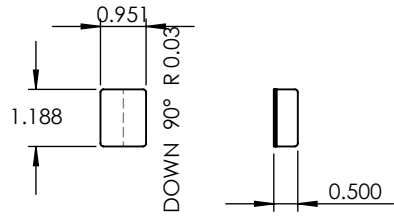

PROPRIETARY AND CONFIDENTIAL
 THE INFORMATION CONTAINED IN THIS DRAWING IS THE SOLE PROPERTY OF <INSERT COMPANY NAME HERE>. ANY REPRODUCTION IN PART OR AS A WHOLE WITHOUT THE WRITTEN PERMISSION OF <INSERT COMPANY NAME HERE> IS PROHIBITED.

		UNLESS OTHERWISE SPECIFIED:	NAME	DATE	22 GAUGE	
		DIMENSIONS ARE IN INCHES TOLERANCES: FRACTIONAL ± ANGULAR: MACH ± BEND ± TWO PLACE DECIMAL ± THREE PLACE DECIMAL ±	DRAWN			
		INTERPRET GEOMETRIC TOLERANCING PER:	CHECKED		CYLSQ-ARM-30W-UD-18X6-MN-CFA-40K	
		MATERIAL	ENG APPR.			
		FINISH	MFG APPR.		SIZE	DWG. NO.
NEXT ASSY	USED ON		Q.A.		A	REV
APPLICATION		DO NOT SCALE DRAWING	COMMENTS:		SCALE: 1:4	WEIGHT:
					SHEET 8 OF 9	

5

4

3

2

1

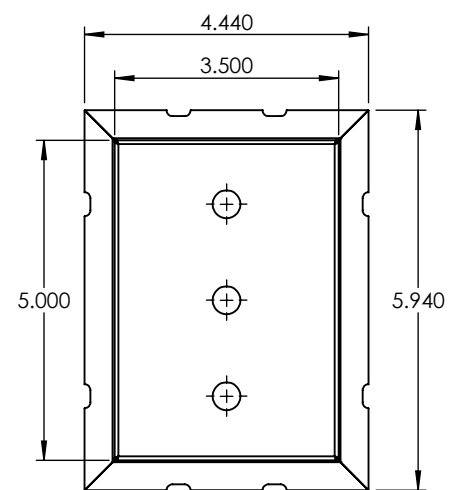
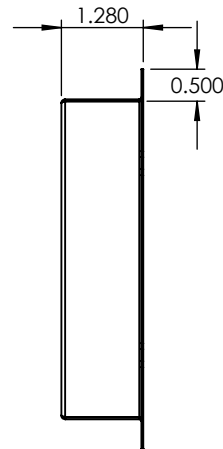
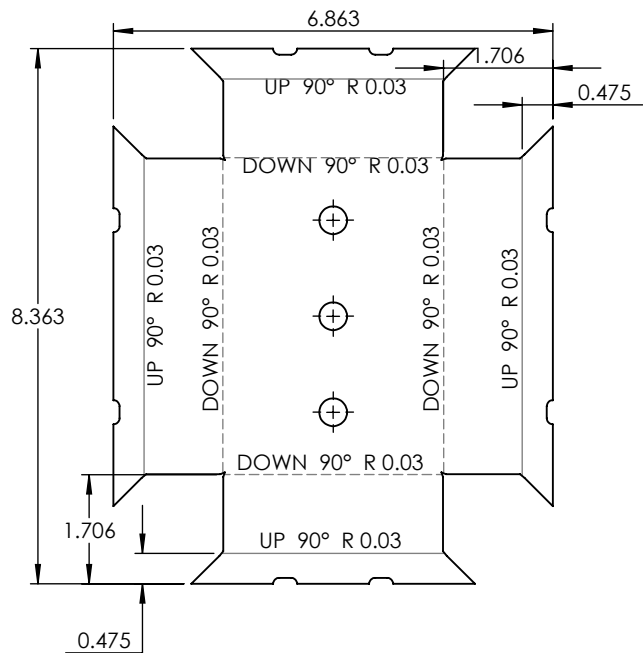
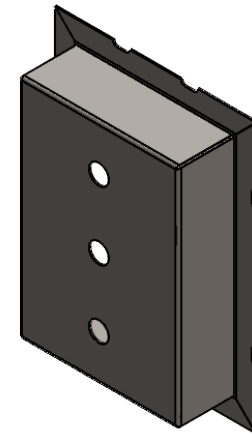

PROPRIETARY AND CONFIDENTIAL
 THE INFORMATION CONTAINED IN THIS DRAWING IS THE SOLE PROPERTY OF <INSERT COMPANY NAME HERE>. ANY REPRODUCTION IN PART OR AS A WHOLE WITHOUT THE WRITTEN PERMISSION OF <INSERT COMPANY NAME HERE> IS PROHIBITED.

		UNLESS OTHERWISE SPECIFIED:	NAME	DATE	22 GAUGE	
		DIMENSIONS ARE IN INCHES TOLERANCES: FRACTIONAL ± ANGULAR: MACH ± BEND ± TWO PLACE DECIMAL ± THREE PLACE DECIMAL ±	DRAWN			
		INTERPRET GEOMETRIC TOLERANCING PER:	CHECKED		SIZE DWG. NO. REV	
		MATERIAL	ENG APPR.			
		FINISH	MFG APPR.		SCALE: 1:3 WEIGHT: SHEET 9 OF 9	
NEXT ASSY	USED ON		Q.A.			
APPLICATION		DO NOT SCALE DRAWING	COMMENTS:			