

UNLESS OTHERWISE SPECIFIED:

DIMENSIONS ARE IN INCHES
 TOLERANCES:
 FRACTIONAL ± .003
 ANGULAR: MACH ± .01 BEND ±
 TWO PLACE DECIMAL ±
 THREE PLACE DECIMAL ±.001

INTERPRET GEOMETRIC
 TOLERANCING PER:

MATERIAL

FINISH

ALL BEND RADIUS .030"

APPLICATION

DO NOT SCALE DRAWING

NAME

DATE

DRAWN

CHECKED

ENG APPR.

MFG APPR.

Q.A.

COMMENTS:

TITLE:

OCT30-PST-60LED-BLK-WF-40K

SIZE DWG. NO.

REV

A TICKET 27396

SCALE: 1:10 WEIGHT:

SHEET 1 OF 10

| ITEM NO. | PART NUMBER | DESCRIPTION | QTY. | CUT |
|----------|---|-------------------------|------|-----|
| 1 | POST FITTER | 3" ALUMINUM POST FITTER | 1 | |
| 2 | OCT30-PST-60LED-BLK-WF-40K-SPUN BOTTOM ACCENT | SPUN ALUMINUM 0.080" | 2 | |
| 3 | OCT30-PST-60LED-BLK-WF-40K-FRAME TABS | ALUMINUM 0.0635" | 12 | |
| 4 | OCT30-PST-60LED-BLK-WF-40K-FITTER PLATE | ALUMINUM 0.0635" | 1 | |
| 5 | OCT30-PST-60LED-BLK-WF-40K-FRAME DOOR | ALUMINUM 0.0635" | 1 | |
| 6 | OCT30-PST-60LED-BLK-WF-40K-TUBE BRACKET | ALUMINUM 0.0635" | 1 | |
| 7 | OCT30-PST-60LED-BLK-WF-40K-DRIVER EXTENSION | ALUMINUM 0.0635" | 4 | |
| 8 | OCT30-PST-60LED-BLK-WF-40K-SQUARE TUBE | 1" SQUARE ALUMINUM TUBE | 1 | |
| 9 | OCT30-PST-60LED-BLK-WF-40K-BODY ACRYLIC | ACRYLIC | 9 | |
| 10 | ESPEN VEL29070MVH-1 | DRIVER | 3 | |
| 11 | AIfailed_PN1010_RevD | LED | 12 | |

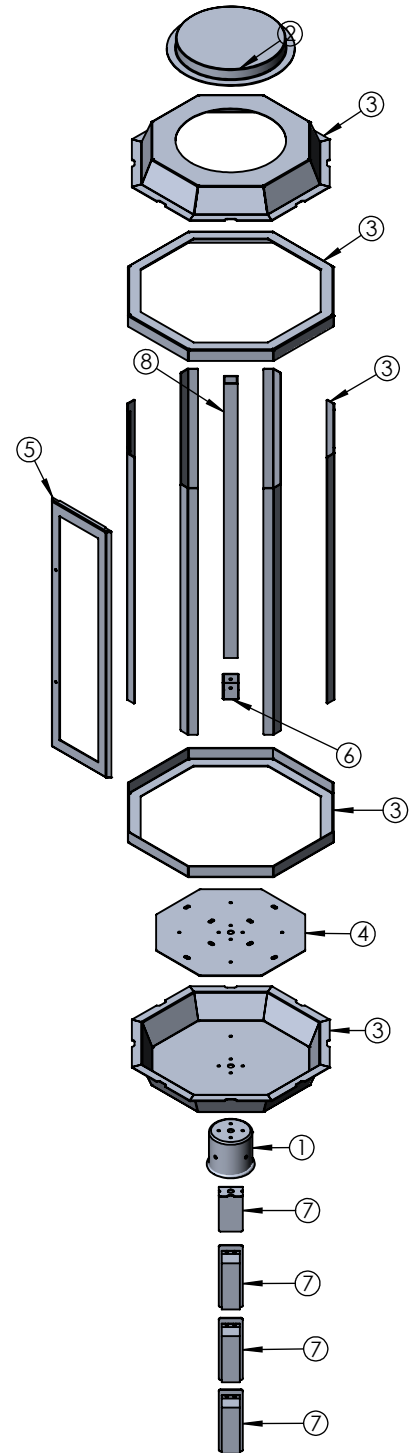

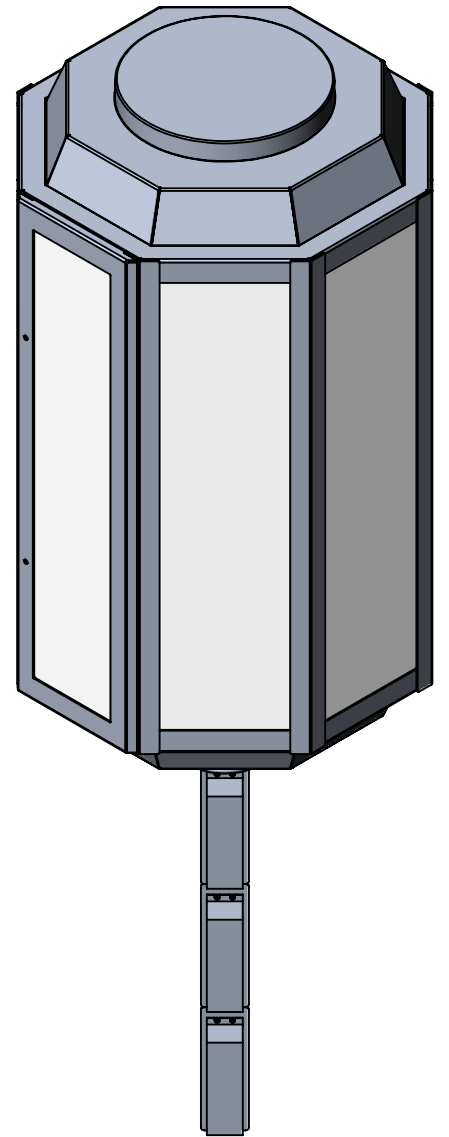
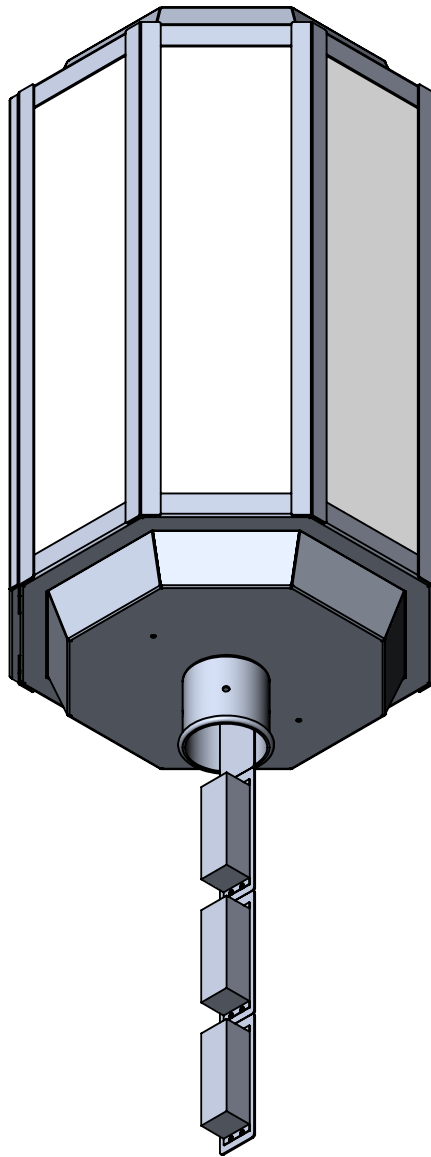
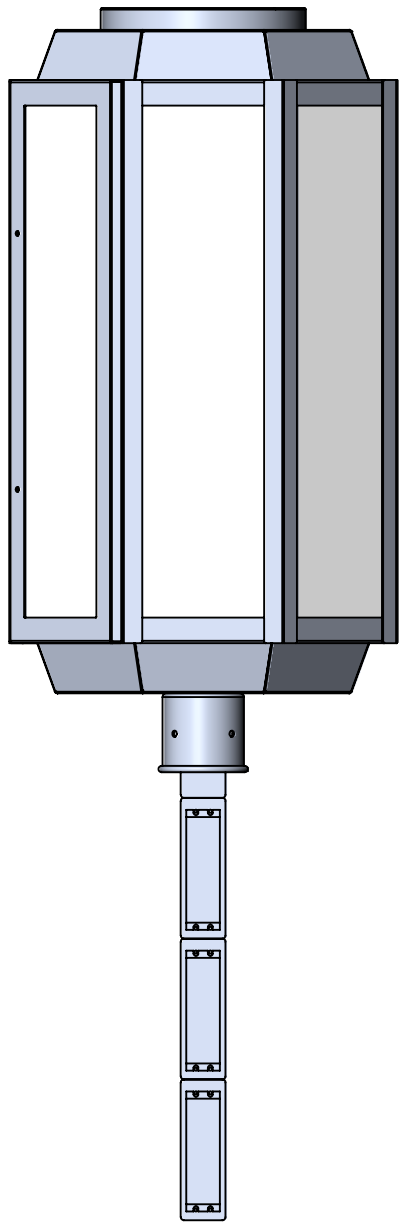

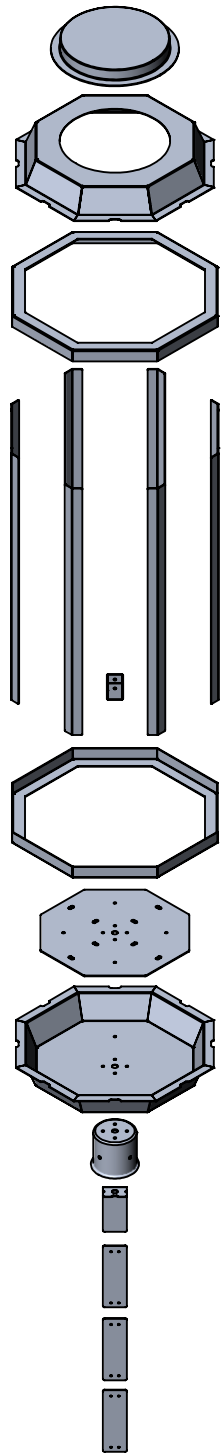

ALL WELDED AS ONE

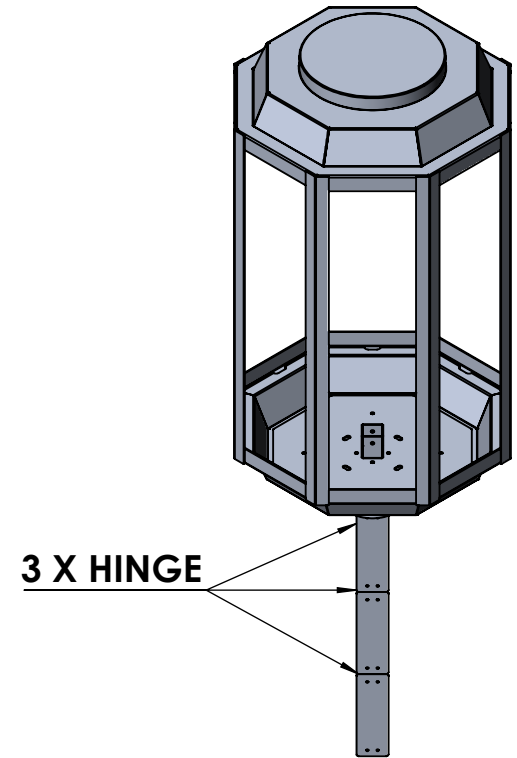

3 X HINGE

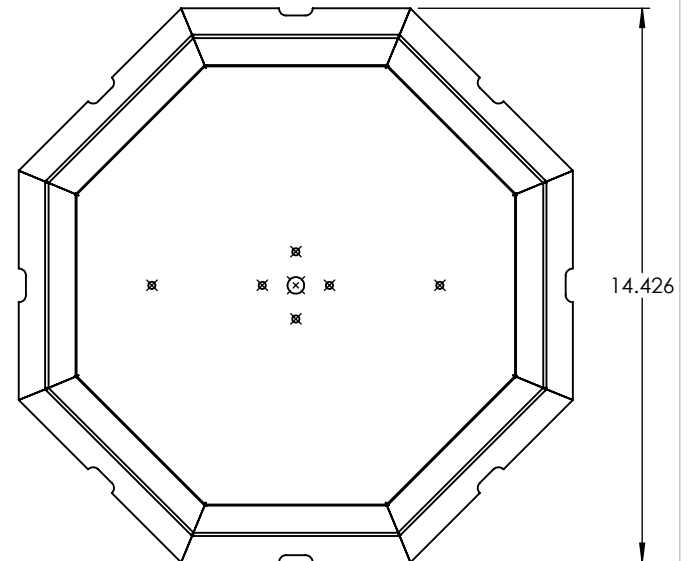
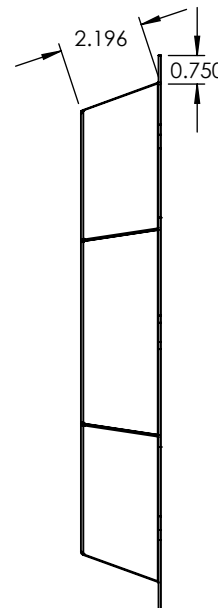
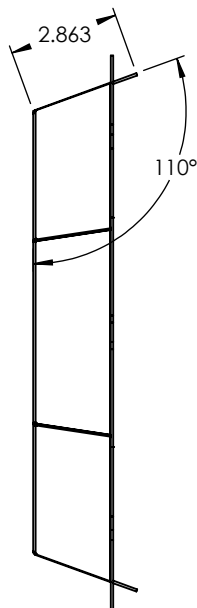
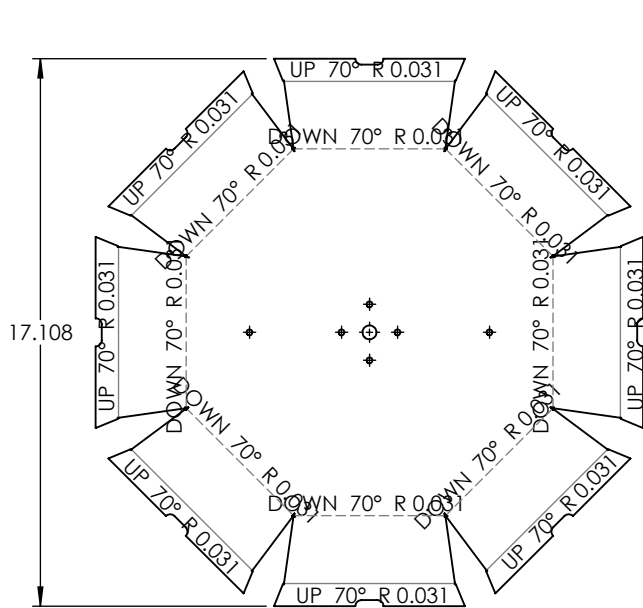
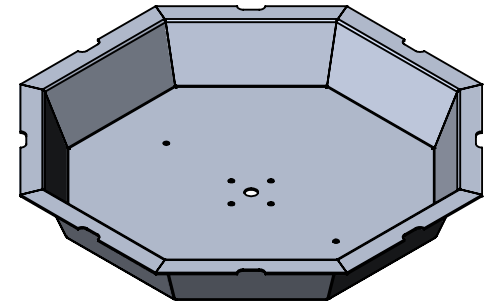
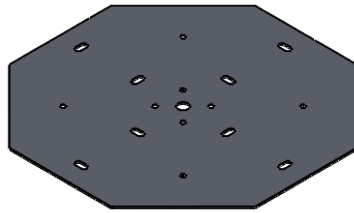
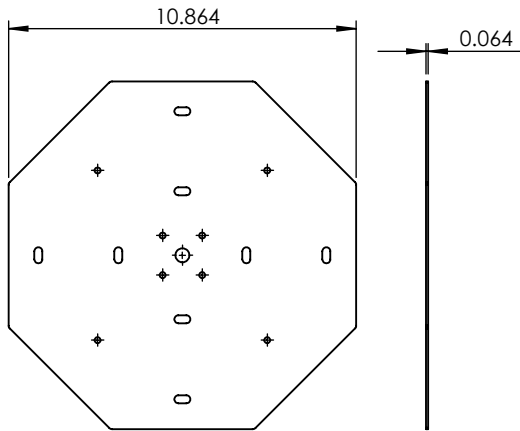

PROPRIETARY AND CONFIDENTIAL
 THE INFORMATION CONTAINED IN THIS DRAWING IS THE SOLE PROPERTY OF <INSERT COMPANY NAME HERE>. ANY REPRODUCTION IN PART OR AS A WHOLE WITHOUT THE WRITTEN PERMISSION OF <INSERT COMPANY NAME HERE> IS PROHIBITED.

| | | | | | |
|-------------|---------|--------------------------------------|-----------|------|------|
| | | UNLESS OTHERWISE SPECIFIED: | | NAME | DATE |
| | | DIMENSIONS ARE IN INCHES | DRAWN | | |
| | | TOLERANCES: | CHECKED | | |
| | | FRACTIONAL ± | ENG APPR. | | |
| | | ANGULAR: MACH ± BEND ± | MFG APPR. | | |
| | | TWO PLACE DECIMAL ± | Q.A. | | |
| | | THREE PLACE DECIMAL ± | COMMENTS: | | |
| | | INTERPRET GEOMETRIC TOLERANCING PER: | | | |
| | | MATERIAL | | | |
| | | FINISH | | | |
| NEXT ASSY | USED ON | | | | |
| APPLICATION | | DO NOT SCALE DRAWING | | | |

ALUMINUM 0.0635"

TITLE:

OCT30-PST-60LED-BLK-WF-40K

| | | |
|----------|----------|-----|
| SIZE | DWG. NO. | REV |
| A | | |

| | | |
|------------|---------|---------------|
| SCALE: 1:6 | WEIGHT: | SHEET 5 OF 10 |
|------------|---------|---------------|

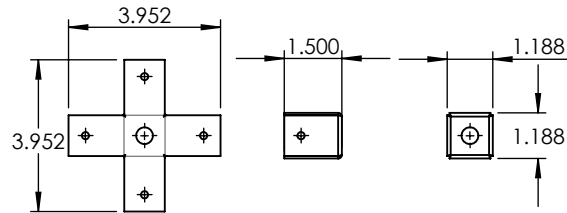
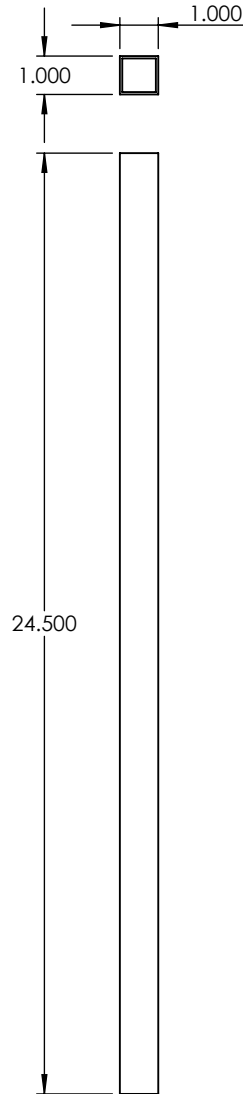
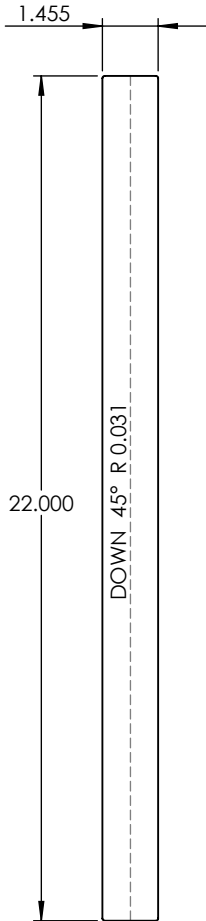
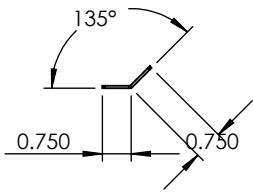

PROPRIETARY AND CONFIDENTIAL
 THE INFORMATION CONTAINED IN THIS DRAWING IS THE SOLE PROPERTY OF <INSERT COMPANY NAME HERE>. ANY REPRODUCTION IN PART OR AS A WHOLE WITHOUT THE WRITTEN PERMISSION OF <INSERT COMPANY NAME HERE> IS PROHIBITED.

| | | | | |
|-------------|---------|--------------------------------------|-----------|------|
| | | UNLESS OTHERWISE SPECIFIED: | NAME | DATE |
| | | DIMENSIONS ARE IN INCHES | DRAWN | |
| | | TOLERANCES: | CHECKED | |
| | | FRACTIONAL ± | ENG APPR. | |
| | | ANGULAR: MACH ± BEND ± | MFG APPR. | |
| | | TWO PLACE DECIMAL ± | Q.A. | |
| | | THREE PLACE DECIMAL ± | COMMENTS: | |
| | | INTERPRET GEOMETRIC TOLERANCING PER: | | |
| | | MATERIAL | | |
| NEXT ASSY | USED ON | FINISH | | |
| APPLICATION | | DO NOT SCALE DRAWING | | |

| | | |
|----------------------------|----------|---------------|
| ALUMINUM 0.0635" | | |
| TITLE: | | |
| OCT30-PST-60LED-BLK-WF-40K | | |
| SIZE | DWG. NO. | REV |
| A | | |
| SCALE: 1:5 | WEIGHT: | SHEET 6 OF 10 |

5

4

3

2

1

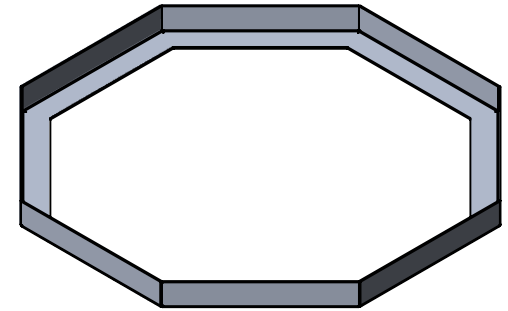
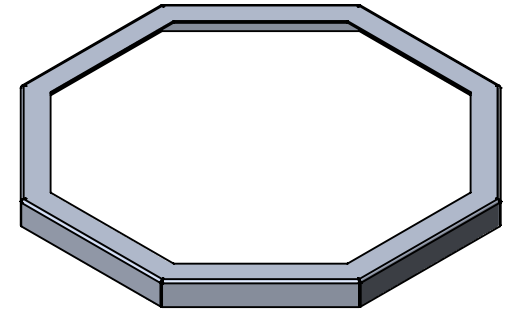
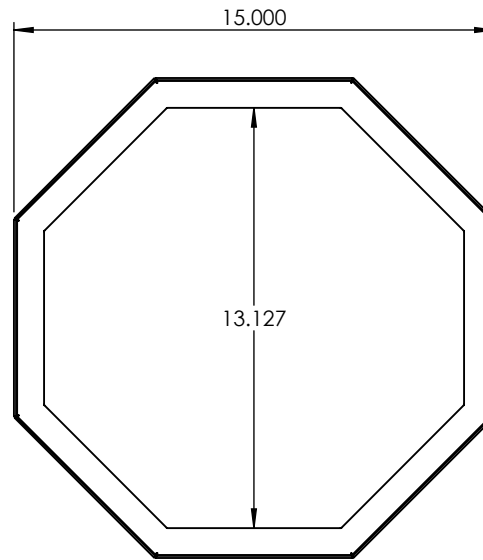
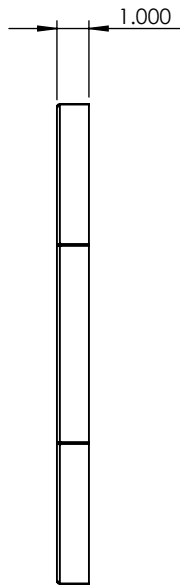
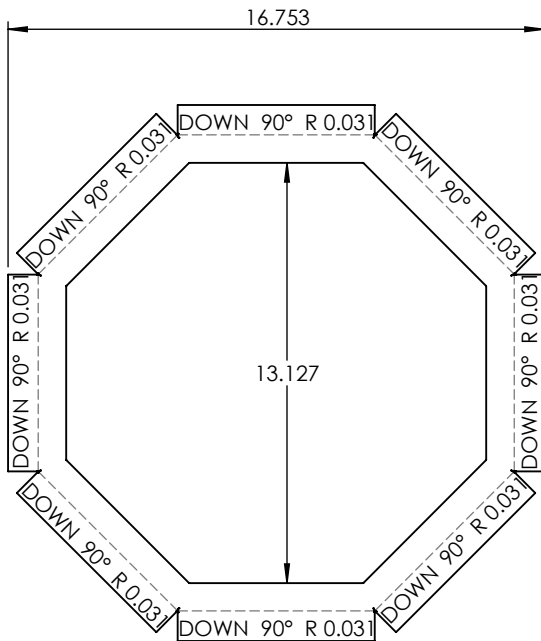

PROPRIETARY AND CONFIDENTIAL
 THE INFORMATION CONTAINED IN THIS DRAWING IS THE SOLE PROPERTY OF <INSERT COMPANY NAME HERE>. ANY REPRODUCTION IN PART OR AS A WHOLE WITHOUT THE WRITTEN PERMISSION OF <INSERT COMPANY NAME HERE> IS PROHIBITED.

| | | | | | | | |
|-------------|---------|--------------------------------------|--|-----------|------|----------------------------|---------------|
| | | UNLESS OTHERWISE SPECIFIED: | | NAME | DATE | ALUMINUM 0.0635" | |
| | | DIMENSIONS ARE IN INCHES | | | | TITLE: | |
| | | TOLERANCES: | | | | OCT30-PST-60LED-BLK-WF-40K | |
| | | FRACTIONAL ± | | DRAWN | | SIZE | DWG. NO. |
| | | ANGULAR: MACH ± BEND ± | | CHECKED | | A | REV |
| | | TWO PLACE DECIMAL ± | | ENG APPR. | | SCALE: 1:6 | WEIGHT: |
| | | THREE PLACE DECIMAL ± | | MFG APPR. | | | SHEET 7 OF 10 |
| | | INTERPRET GEOMETRIC TOLERANCING PER: | | Q.A. | | | |
| | | MATERIAL | | COMMENTS: | | | |
| NEXT ASSY | USED ON | FINISH | | | | | |
| APPLICATION | | DO NOT SCALE DRAWING | | | | | |

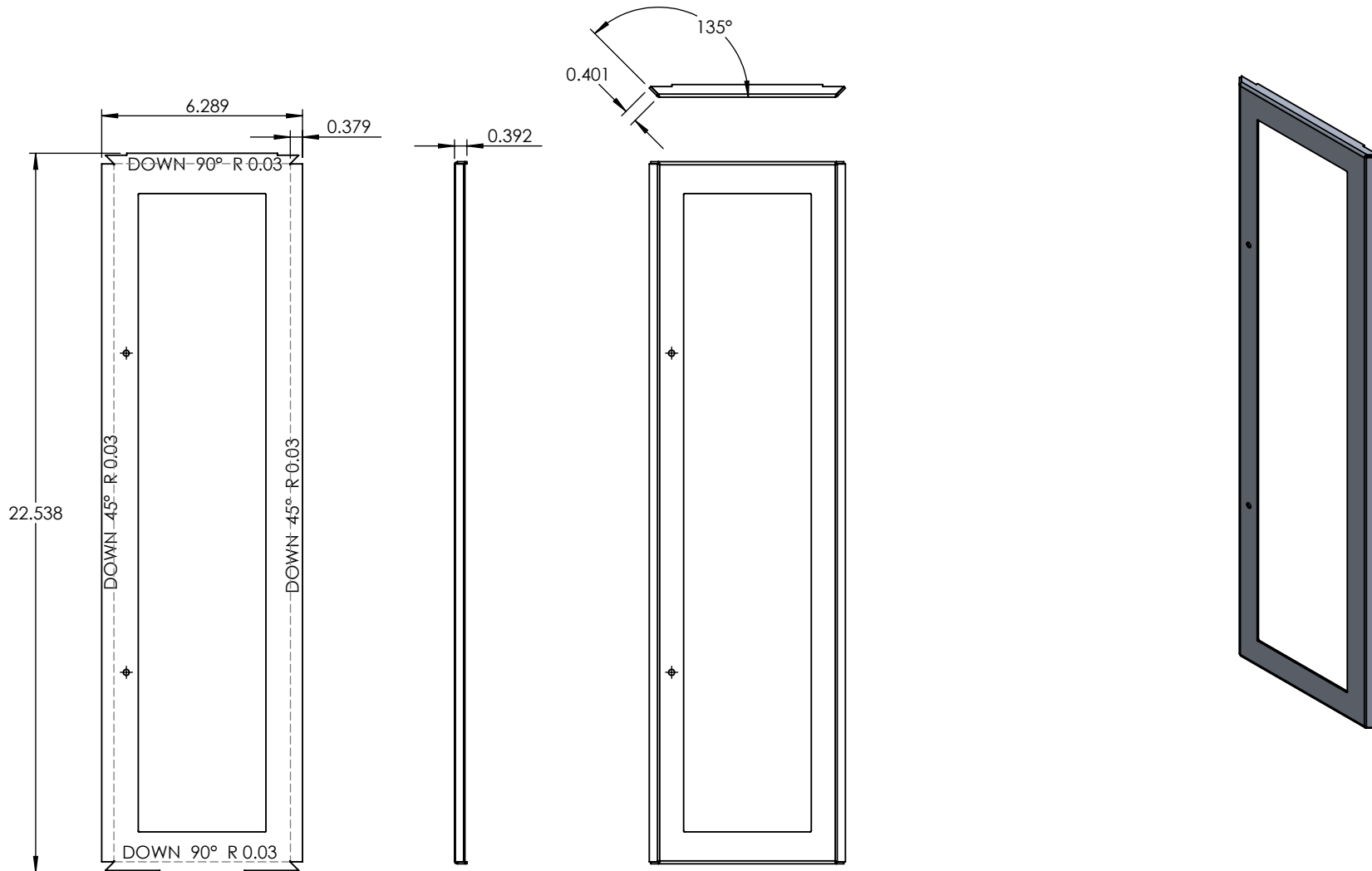

PROPRIETARY AND CONFIDENTIAL
 THE INFORMATION CONTAINED IN THIS DRAWING IS THE SOLE PROPERTY OF <INSERT COMPANY NAME HERE>. ANY REPRODUCTION IN PART OR AS A WHOLE WITHOUT THE WRITTEN PERMISSION OF <INSERT COMPANY NAME HERE> IS PROHIBITED.

| | | | | | |
|-------------|---------|--------------------------------------|-----------|------|------|
| | | UNLESS OTHERWISE SPECIFIED: | | NAME | DATE |
| | | DIMENSIONS ARE IN INCHES | DRAWN | | |
| | | TOLERANCES: | CHECKED | | |
| | | FRACTIONAL ± | ENG APPR. | | |
| | | ANGULAR: MACH ± BEND ± | MFG APPR. | | |
| | | TWO PLACE DECIMAL ± | Q.A. | | |
| | | THREE PLACE DECIMAL ± | COMMENTS: | | |
| | | INTERPRET GEOMETRIC TOLERANCING PER: | | | |
| | | MATERIAL | | | |
| | | FINISH | | | |
| NEXT ASSY | USED ON | | | | |
| APPLICATION | | DO NOT SCALE DRAWING | | | |

| | | |
|----------------------------|----------|---------------|
| PAINTLOCK | | |
| TITLE: | | |
| OCT30-PST-60LED-BLK-WF-40K | | |
| SIZE | DWG. NO. | REV |
| A | | |
| SCALE: 1:5 | WEIGHT: | SHEET 8 OF 10 |

5

4

3

2

1

| ITEM NO. | PART NUMBER | DESCRIPTION | QTY. |
|----------|-------------|-------------------------|------|
| 1 | POST FITTER | 3" ALUMINUM POST FITTER | 1 |

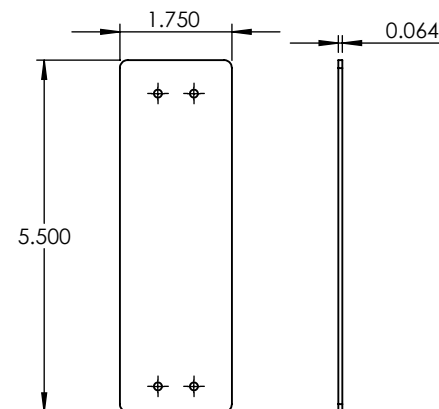
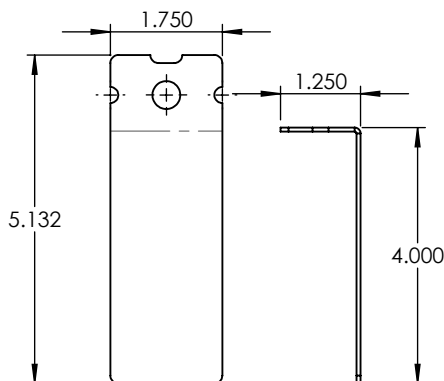
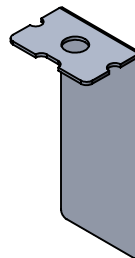
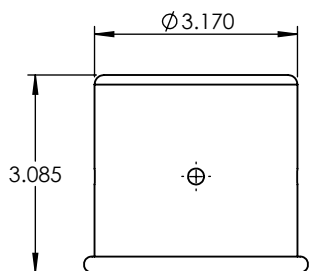
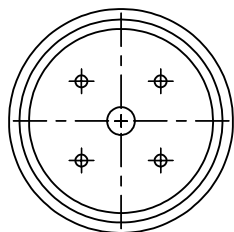
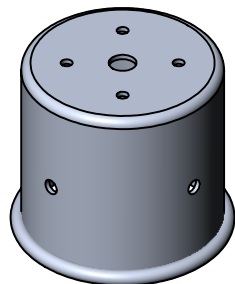

PROPRIETARY AND CONFIDENTIAL
 THE INFORMATION CONTAINED IN THIS DRAWING IS THE SOLE PROPERTY OF <INSERT COMPANY NAME HERE>. ANY REPRODUCTION IN PART OR AS A WHOLE WITHOUT THE WRITTEN PERMISSION OF <INSERT COMPANY NAME HERE> IS PROHIBITED.

| | | UNLESS OTHERWISE SPECIFIED: | NAME | DATE |
|-------------|---------|---|-----------|------|
| | | DIMENSIONS ARE IN INCHES TOLERANCES: FRACTIONAL ± ANGULAR: MACH ± BEND ± TWO PLACE DECIMAL ± THREE PLACE DECIMAL ± | DRAWN | |
| | | INTERPRET GEOMETRIC TOLERANCING PER: | CHECKED | |
| | | MATERIAL | ENG APPR. | |
| | | FINISH | MFG APPR. | |
| | | | Q.A. | |
| | | | COMMENTS: | |
| NEXT ASSY | USED ON | | | |
| APPLICATION | | DO NOT SCALE DRAWING | | |

3" STEEL POST FITTER

TITLE:

OCT30-PST-60LED-BLK-WF-40K

| SIZE | DWG. NO. | REV |
|----------|----------|-----|
| A | | |

SCALE: 1:3 WEIGHT: SHEET 9 OF 10

| ITEM NO. | PART NUMBER | DESCRIPTION | QTY. |
|----------|--|----------------------|------|
| 1 | OCT30-PST-60LED-BLK-WF-40K-SPUN TOP ACCENT | SPUN ALUMINUM 0.080" | 1 |

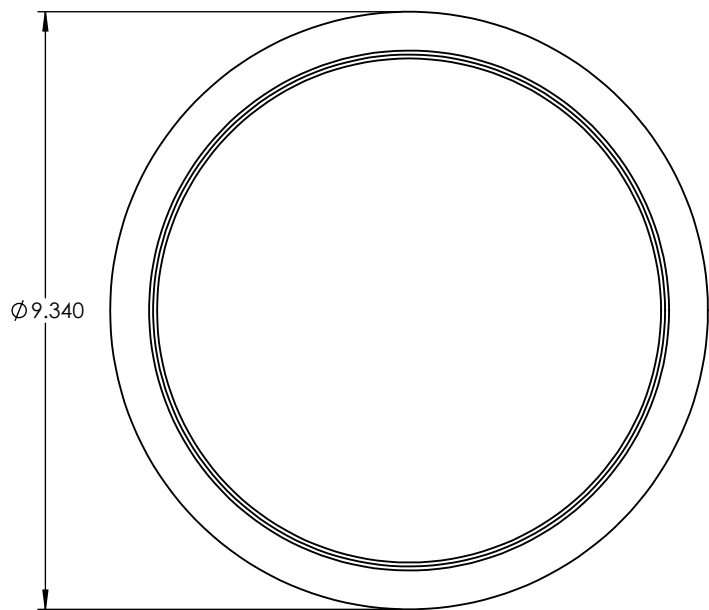
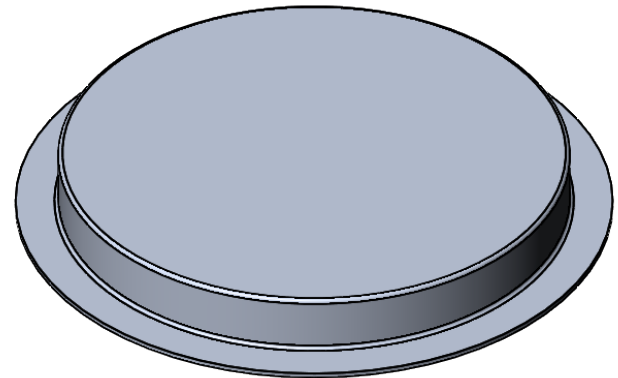
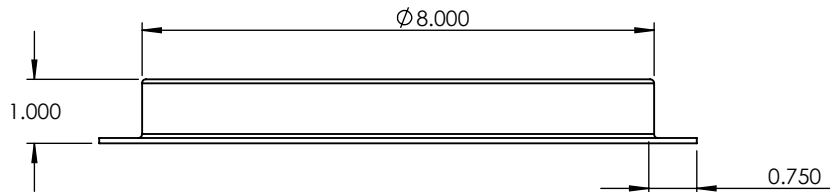

| | | | | | | |
|---|--|-----------|------|----------------------------|----------|----------------|
| UNLESS OTHERWISE SPECIFIED: | | NAME | DATE | SPUN ALUMINUM 0.080" | | |
| DIMENSIONS ARE IN INCHES TOLERANCES: FRACTIONAL ± ANGULAR: MACH ± BEND ± TWO PLACE DECIMAL ± THREE PLACE DECIMAL ± | | DRAWN | | | | TITLE: |
| INTERPRET GEOMETRIC TOLERANCING PER: | | CHECKED | | OCT30-PST-60LED-BLK-WF-40K | | |
| | | ENG APPR. | | SIZE | DWG. NO. | REV |
| | | MFG APPR. | | A | | |
| MATERIAL | | Q.A. | | SCALE: 1:3 | WEIGHT: | SHEET 10 OF 10 |
| FINISH | | COMMENTS: | | | | |
| DO NOT SCALE DRAWING | | | | | | |

PROPRIETARY AND CONFIDENTIAL
THE INFORMATION CONTAINED IN THIS DRAWING IS THE SOLE PROPERTY OF <INSERT COMPANY NAME HERE>. ANY REPRODUCTION IN PART OR AS A WHOLE WITHOUT THE WRITTEN PERMISSION OF <INSERT COMPANY NAME HERE> IS PROHIBITED.

| | |
|-------------|---------|
| NEXT ASSY | USED ON |
| APPLICATION | |