

ITEM NO.	PART NUMBER	DESCRIPTION	QTY.	CUT
1	CHTRI-2ARM-50W-BA-WF-DIM-WET-35K-FRONT FRAME	ALUMINUM 0.0635"	1	
2	CHTRI-2ARM-50W-BA-WF-DIM-WET-35K-ACRYLIC	ALUMINUM 0.0635"	1	
3	CHTRI-2ARM-50W-BA-WF-DIM-WET-35K-FRAME END	ALUMINUM 0.0635"	2	
4	CHTRI-2ARM-50W-BA-WF-DIM-WET-35K-FRAME STRAP	ALUMINUM 0.0635"	3	
5	CHTRI-2ARM-50W-BA-WF-DIM-WET-35K-FRAME PLATE	ALUMINUM 0.0635"	1	
6	CHTRI-2ARM-50W-BA-WF-DIM-WET-35K-COVER BRACKET	ALUMINUM 0.0635"	1	
7	CHTRI-2ARM-50W-BA-WF-DIM-WET-35K-FIREPLATE	ALUMINUM 0.0635"	2	
8	CHTRI-2ARM-50W-BA-WF-DIM-WET-35K-BACKPLATE	ALUMINUM 0.0635"	2	
9	CHTRI-2ARM-50W-BA-WF-DIM-WET-35K-LED SPACER	ALUMINUM 0.0635"	1	
10	CHTRI-2ARM-50W-BA-WF-DIM-WET-35K-COVER PLATE	ALUMINUM 0.0635"	1	
11	CHTRI-2ARM-50W-BA-WF-DIM-WET-35K-SQUARE ARM TUBE	3" SQUARE ALUMINUM TUBE	2	
12	CHTRI-2ARM-50W-BA-WF-DIM-WET-35K-TUBE BRACKET PLATE	ALUMINUM 0.250" PLATE	4	
13	Altailed PN107B-11-SS	LED	6	
14	KTLD-25-UV-700-VDIM-LA1	DRIVER	3	

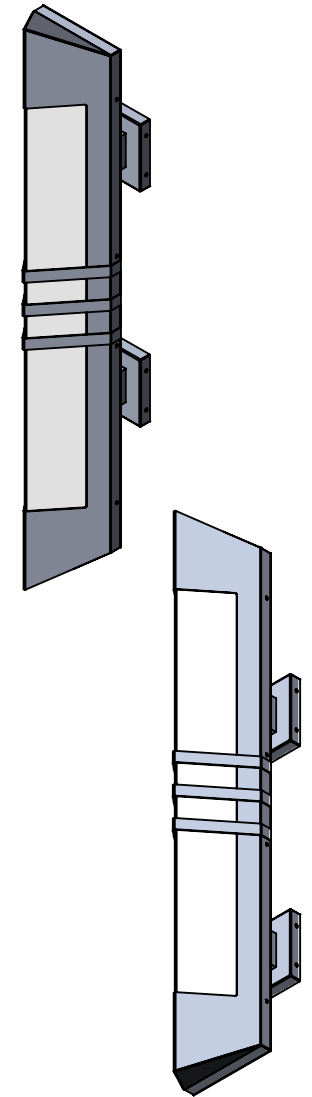
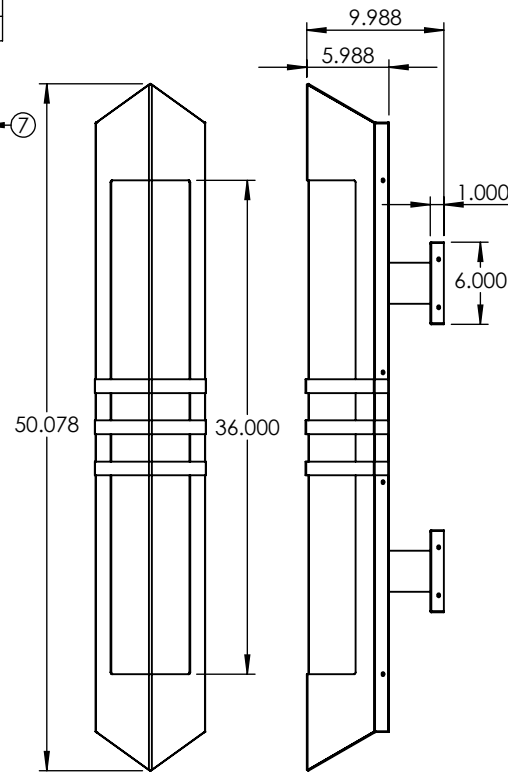
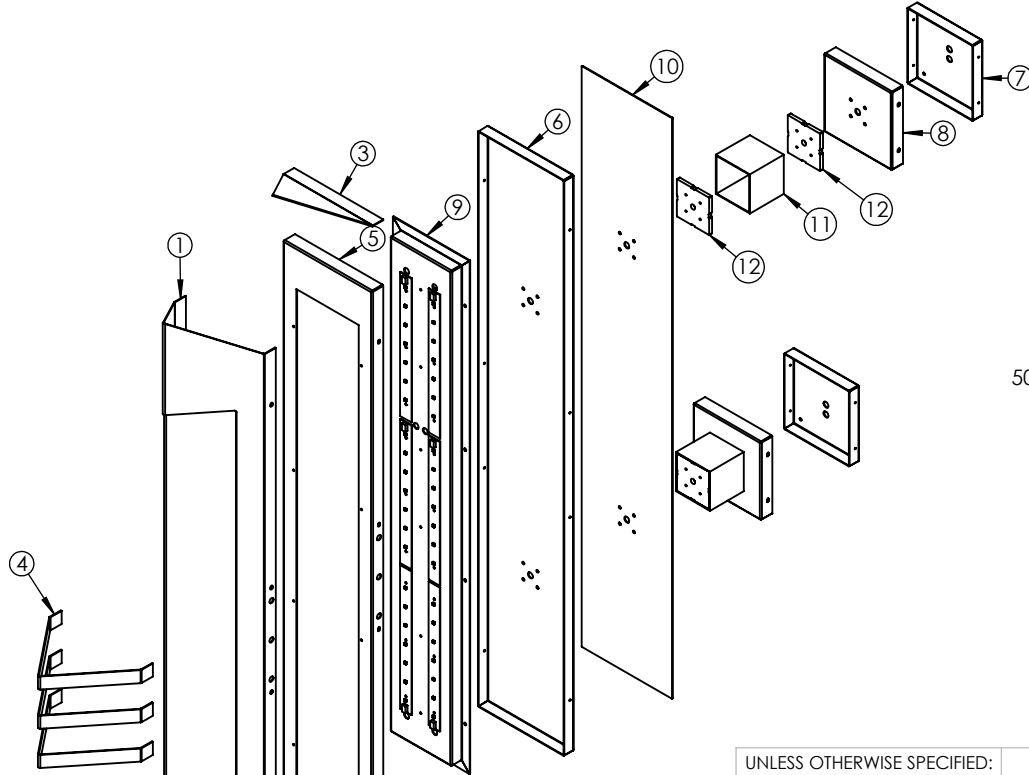

ALL BEND RADIUS .030"

APPLICATION

DO NOT SCALE DRAWING

UNLESS OTHERWISE SPECIFIED:

DIMENSIONS ARE IN INCHES
 TOLERANCES:
 FRACTIONAL ± .003
 ANGULAR: MACH ± .01 BEND ±
 TWO PLACE DECIMAL ±
 THREE PLACE DECIMAL ±.001

INTERPRET GEOMETRIC
 TOLERANCING PER:
 MATERIAL

FINISH

NAME

DATE

DRAWN

CHECKED

ENG APPR.

MFG APPR.

Q.A.

COMMENTS:

TITLE:

CHTRI-2ARM-50W-BA-WF-DIM-WET-35K

SIZE DWG. NO.

A TICKET 27403

REV

SCALE: 1:12 WEIGHT:

SHEET 1 OF 12

5

4

3

2

1

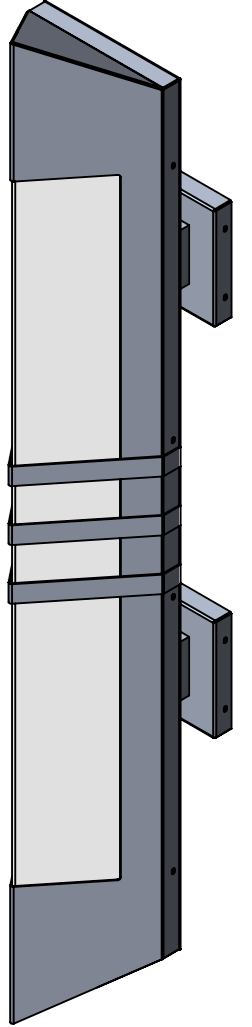
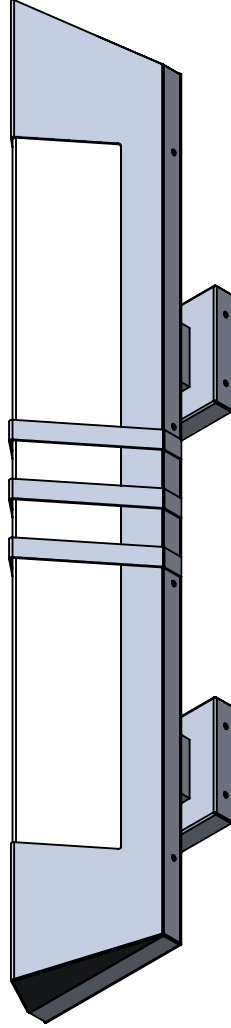
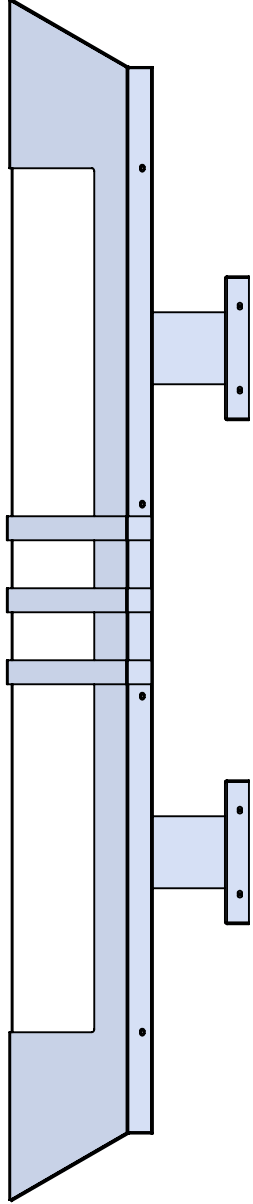
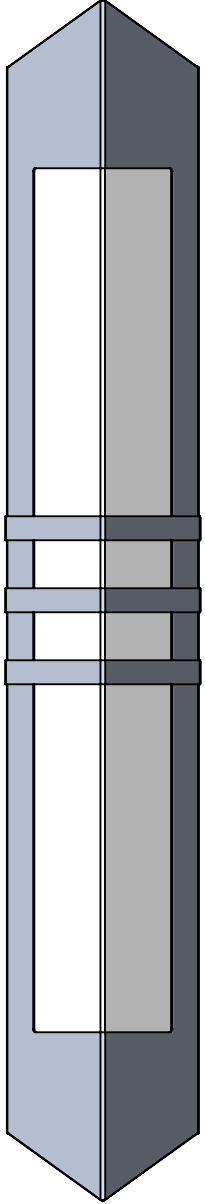
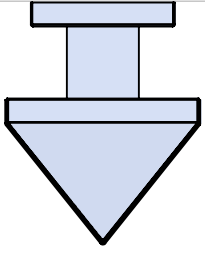

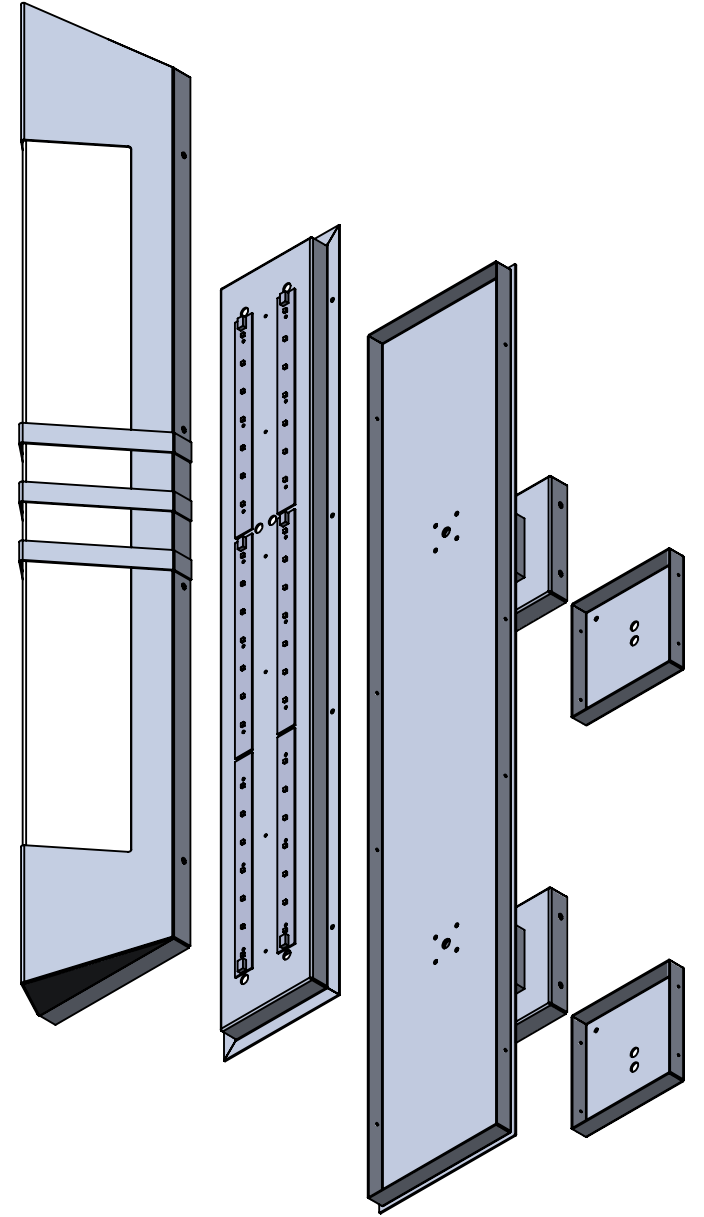
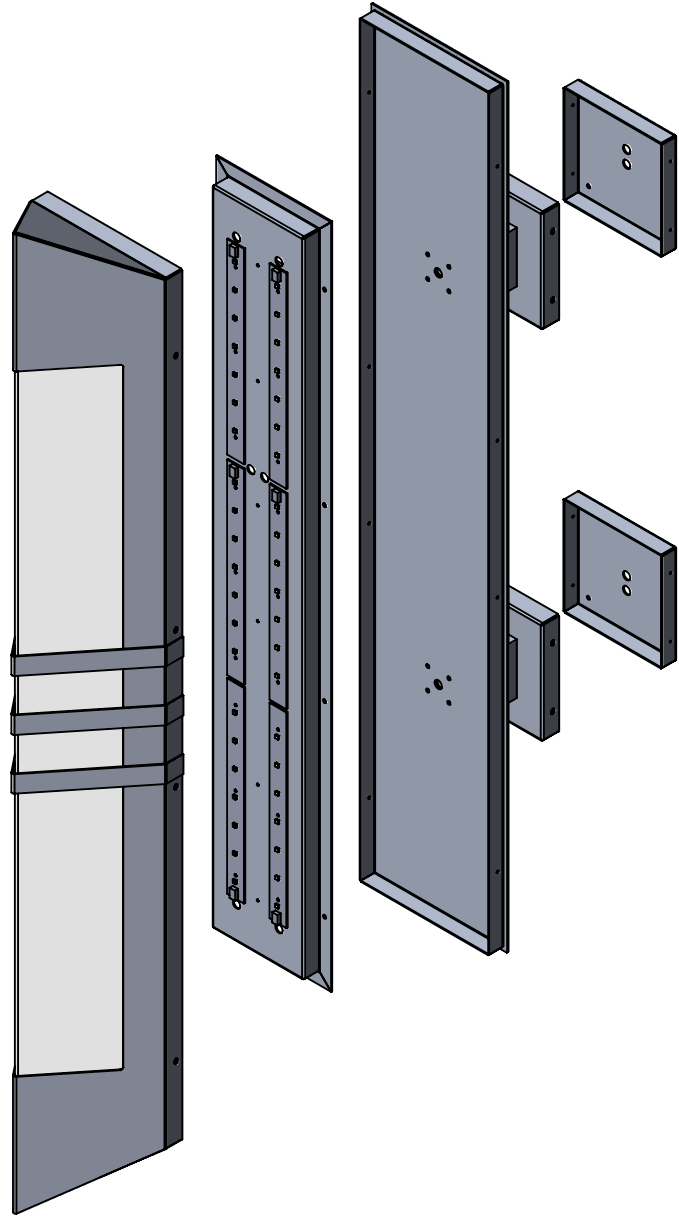

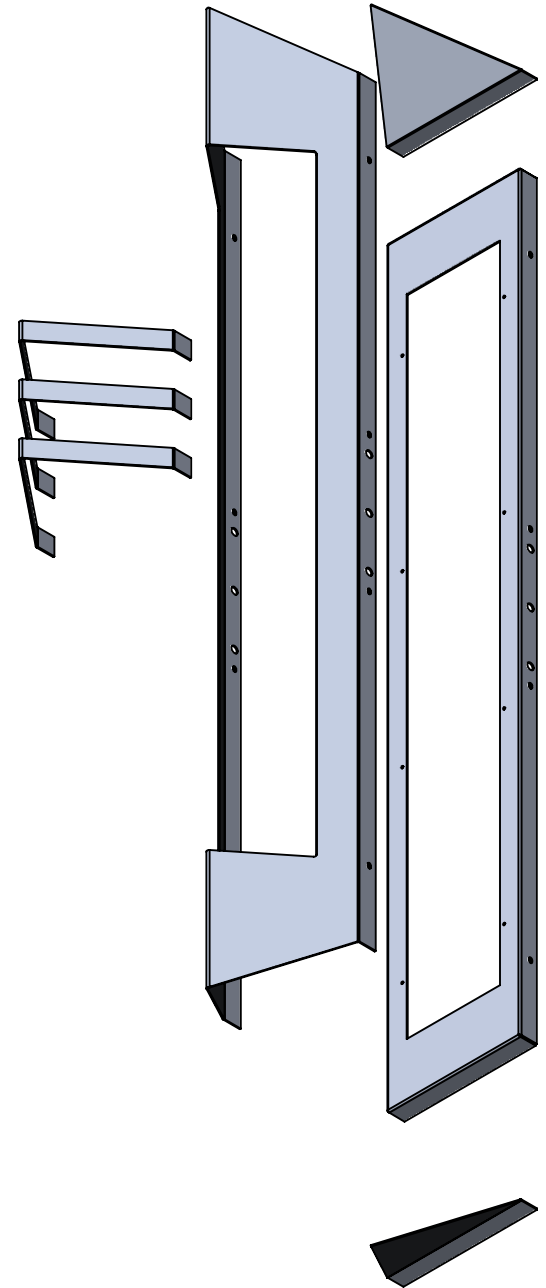
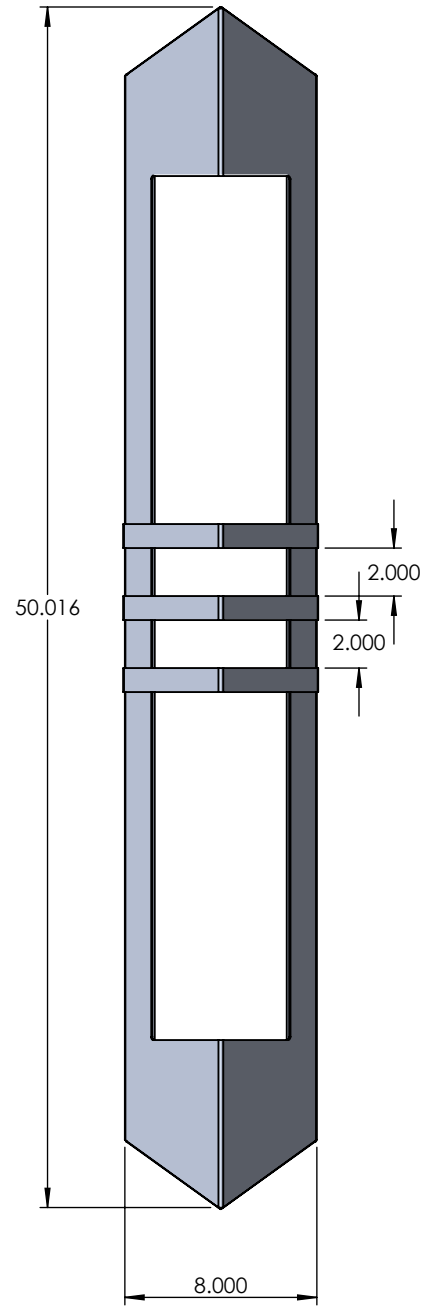
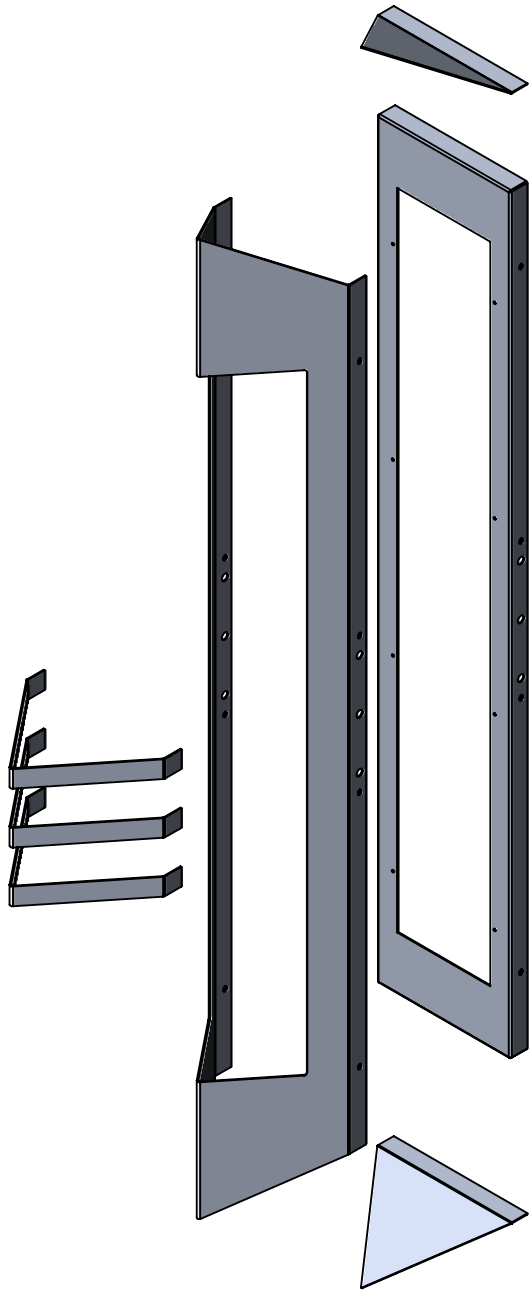

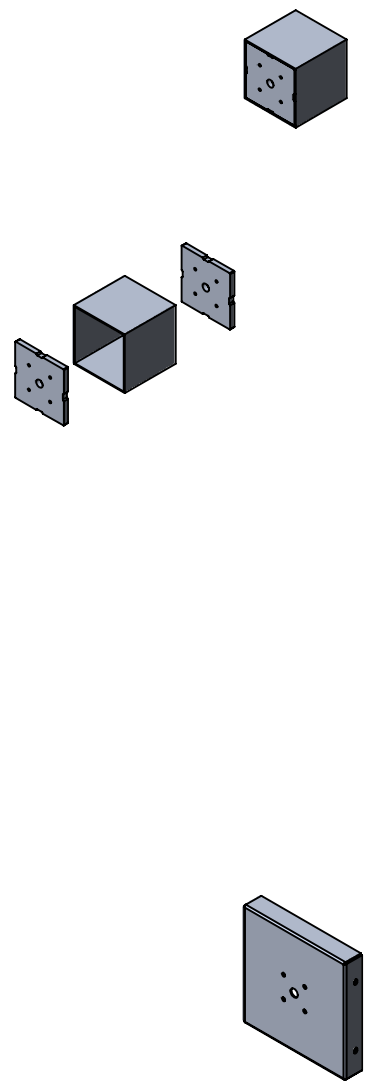
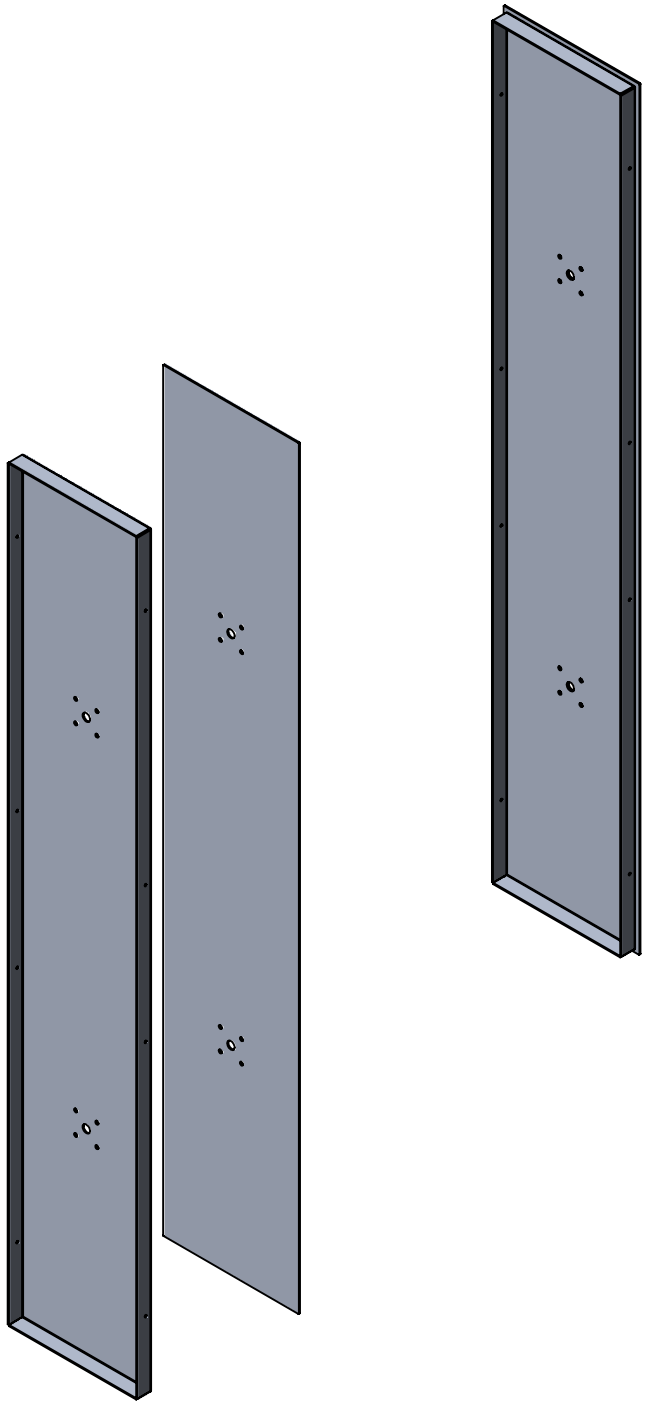

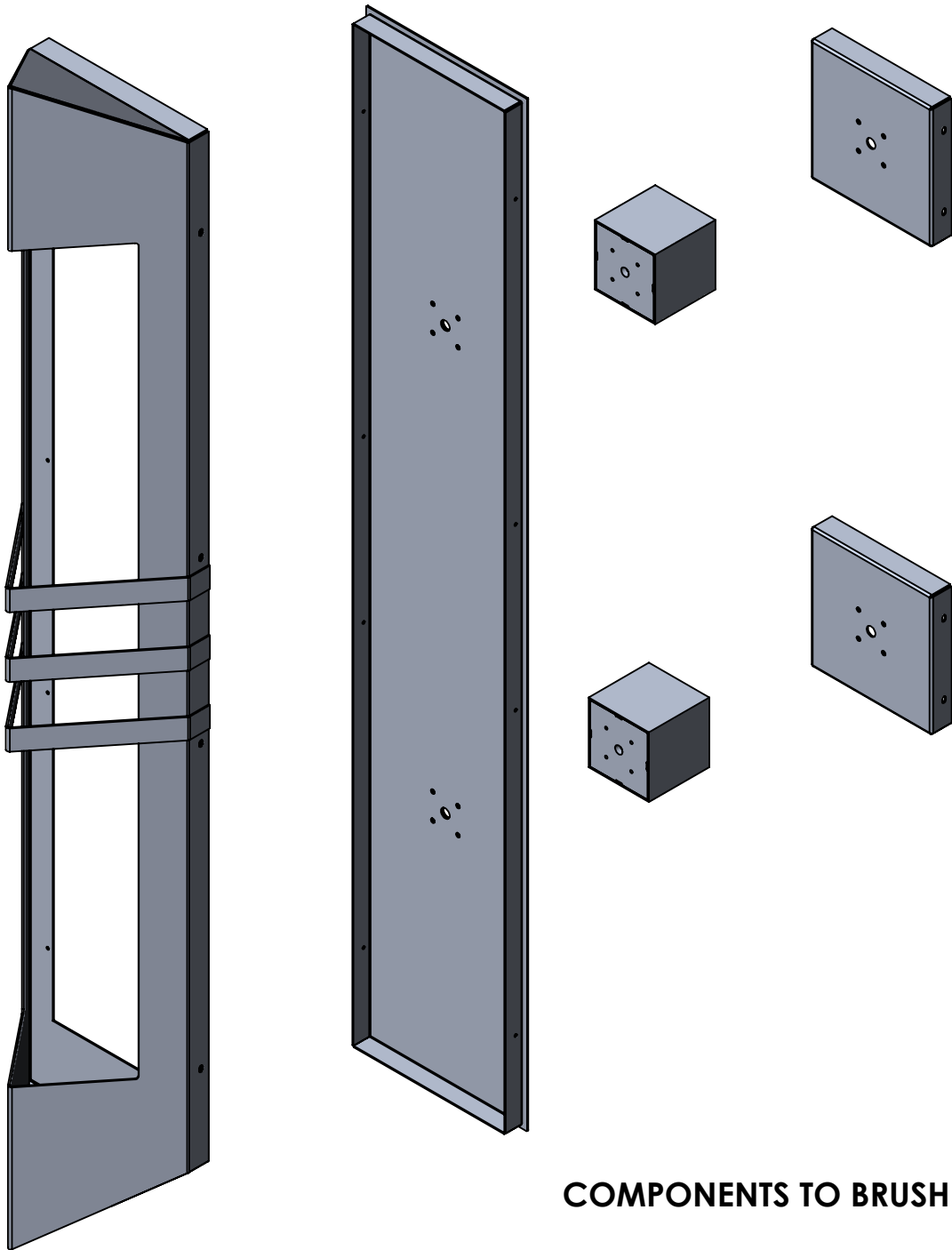

COMPONENTS TO BRUSH AND THEIR CONFIGURATION

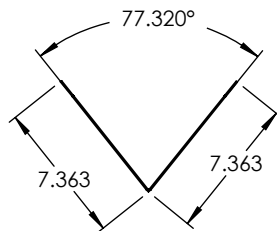
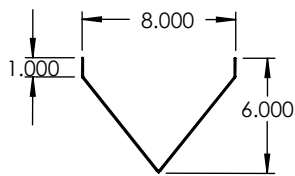
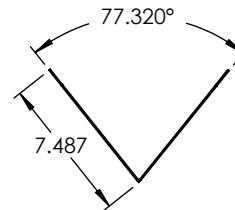
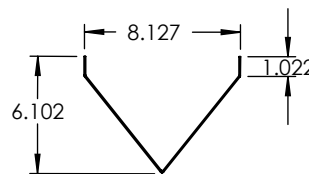
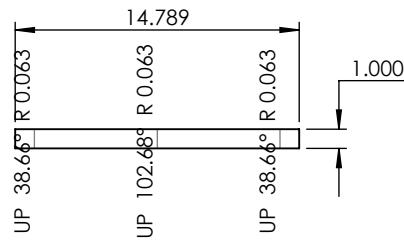
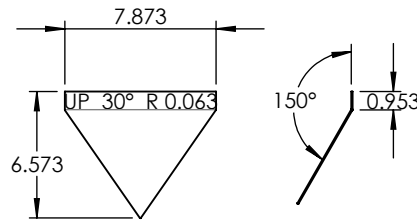
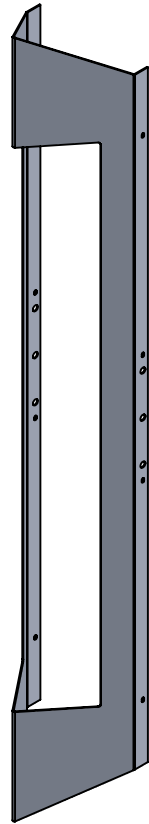
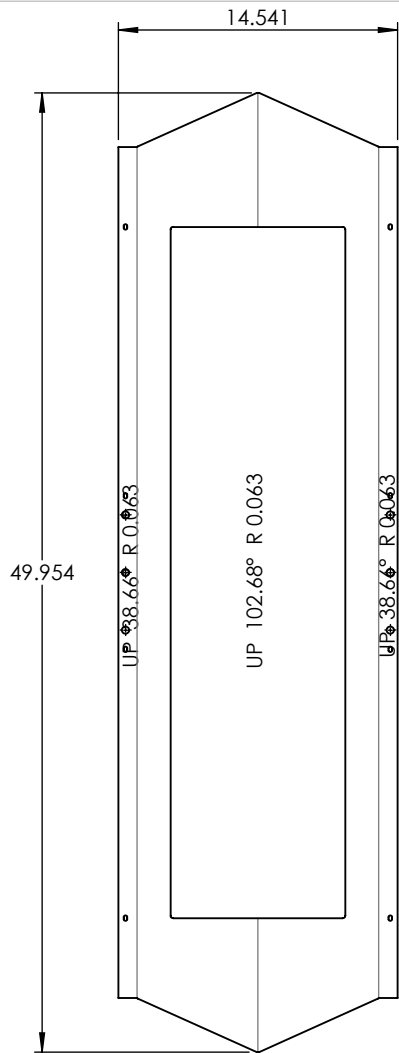

UNLESS OTHERWISE SPECIFIED:

DIMENSIONS ARE IN INCHES
 TOLERANCES:
 FRACTIONAL ±
 ANGULAR: MACH ± BEND ±
 TWO PLACE DECIMAL ±
 THREE PLACE DECIMAL ±

INTERPRET GEOMETRIC
 TOLERANCING PER:

MATERIAL

FINISH

NAME DATE

DRAWN
 CHECKED
 ENG APPR.
 MFG APPR.

Q.A.
 COMMENTS:

ALUMINUM 0.064"

TITLE:
 CHTRI-2ARM-50W-BA-WF-DIM-WET-35K

PROPRIETARY AND CONFIDENTIAL

THE INFORMATION CONTAINED IN THIS
 DRAWING IS THE SOLE PROPERTY OF
 <INSERT COMPANY NAME HERE>. ANY
 REPRODUCTION IN PART OR AS A WHOLE
 WITHOUT THE WRITTEN PERMISSION OF
 <INSERT COMPANY NAME HERE> IS
 PROHIBITED.

NEXT ASSY	USED ON
APPLICATION	

DO NOT SCALE DRAWING

SIZE	DWG. NO.	REV
A		
SCALE: 1:10	WEIGHT:	SHEET 7 OF 12

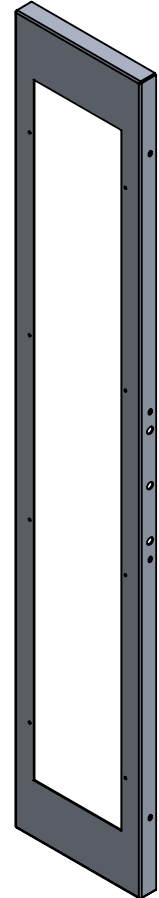
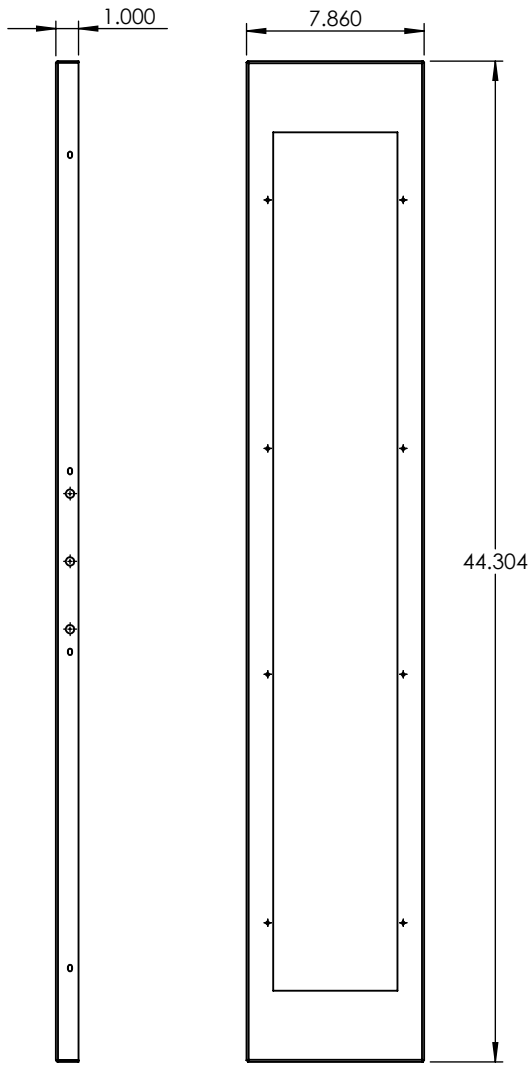
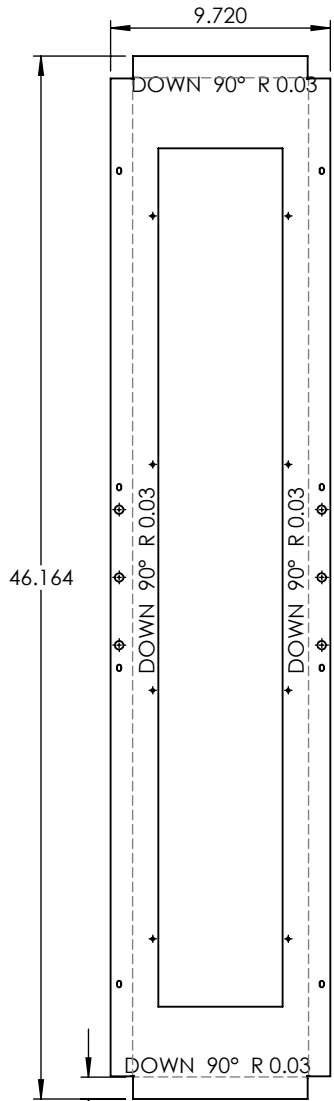

0.965

PROPRIETARY AND CONFIDENTIAL
 THE INFORMATION CONTAINED IN THIS DRAWING IS THE SOLE PROPERTY OF <INSERT COMPANY NAME HERE>. ANY REPRODUCTION IN PART OR AS A WHOLE WITHOUT THE WRITTEN PERMISSION OF <INSERT COMPANY NAME HERE> IS PROHIBITED.

		UNLESS OTHERWISE SPECIFIED:		NAME	DATE
		DIMENSIONS ARE IN INCHES	DRAWN		
		TOLERANCES:	CHECKED		
		FRACTIONAL ±	ENG APPR.		
		ANGULAR: MACH ± BEND ±	MFG APPR.		
		TWO PLACE DECIMAL ±	Q.A.		
		THREE PLACE DECIMAL ±	COMMENTS:		
		INTERPRET GEOMETRIC TOLERANCING PER:			
		MATERIAL			
NEXT ASSY	USED ON	FINISH			
APPLICATION		DO NOT SCALE DRAWING			

ALUMINUM 0.0635"		
TITLE:		
CHTRI-2ARM-50W-BA-WF-DIM-WET-35K		
SIZE	DWG. NO.	REV
A		
SCALE: 1:8.5		WEIGHT:
		SHEET 8 OF 12

5

4

3

2

1

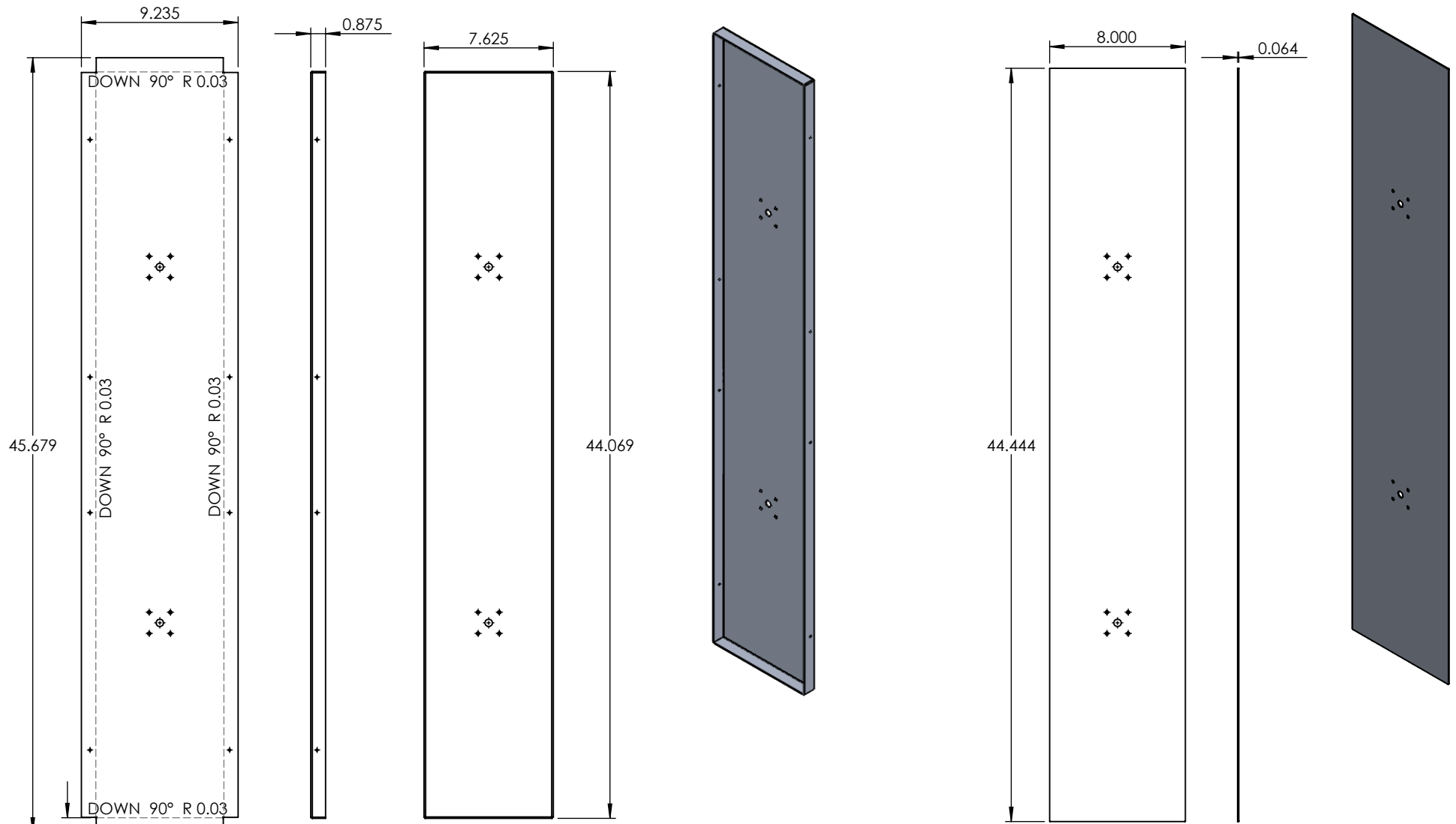

0.840

PROPRIETARY AND CONFIDENTIAL

THE INFORMATION CONTAINED IN THIS DRAWING IS THE SOLE PROPERTY OF <INSERT COMPANY NAME HERE>. ANY REPRODUCTION IN PART OR AS A WHOLE WITHOUT THE WRITTEN PERMISSION OF <INSERT COMPANY NAME HERE> IS PROHIBITED.

		UNLESS OTHERWISE SPECIFIED:	NAME	DATE	ALUMINUM 0.0635"	
		DIMENSIONS ARE IN INCHES	DRAWN		TITLE:	
		TOLERANCES:	CHECKED		CHTRI-2ARM-50W-BA-WF-DIM-WET-35K	
		FRACTIONAL ±	ENG APPR.		SIZE DWG. NO. REV	
		ANGULAR: MACH ± BEND ±	MFG APPR.		SCALE: 1:8.5 WEIGHT: SHEET 9 OF 12	
		TWO PLACE DECIMAL ±	Q.A.			
		THREE PLACE DECIMAL ±	COMMENTS:			
		INTERPRET GEOMETRIC TOLERANCING PER:				
		MATERIAL				
		FINISH				
NEXT ASSY	USED ON	APPLICATION				
		DO NOT SCALE DRAWING				

5

4

3

2

1

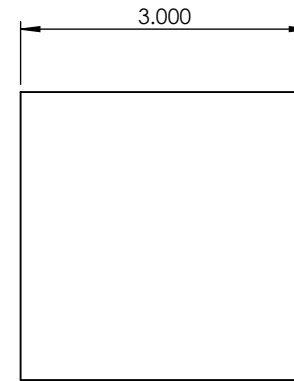
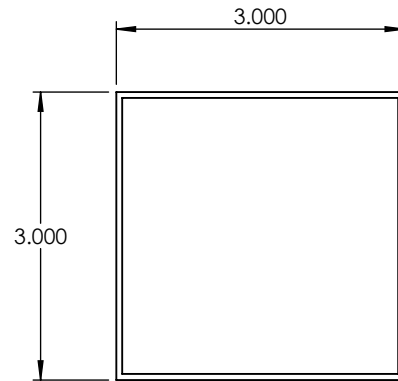
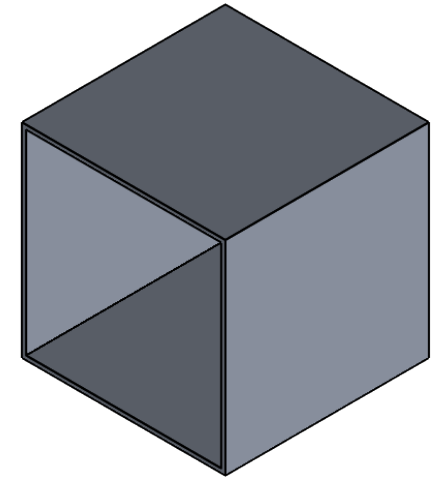
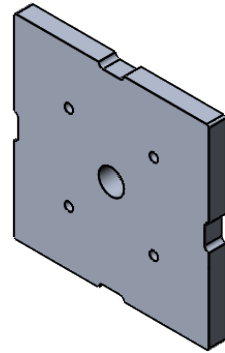
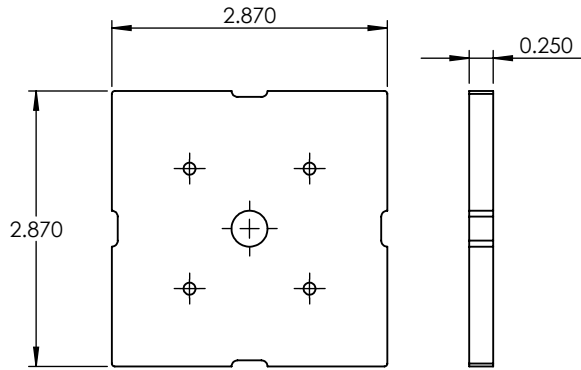

PROPRIETARY AND CONFIDENTIAL
 THE INFORMATION CONTAINED IN THIS DRAWING IS THE SOLE PROPERTY OF <INSERT COMPANY NAME HERE>. ANY REPRODUCTION IN PART OR AS A WHOLE WITHOUT THE WRITTEN PERMISSION OF <INSERT COMPANY NAME HERE> IS PROHIBITED.

		UNLESS OTHERWISE SPECIFIED:	NAME	DATE	ALUMINUM 0.250" PLATE	
		DIMENSIONS ARE IN INCHES TOLERANCES: FRACTIONAL ± ANGULAR: MACH ± BEND ± TWO PLACE DECIMAL ± THREE PLACE DECIMAL ±	DRAWN			
		INTERPRET GEOMETRIC TOLERANCING PER:	CHECKED		CHTRI-2ARM-50W-BA-WF-DIM-WET-35K	
		MATERIAL	ENG APPR.			
		FINISH	MFG APPR.		SIZE	DWG. NO.
NEXT ASSY	USED ON		Q.A.		A	REV
APPLICATION		DO NOT SCALE DRAWING	COMMENTS:		SCALE: 1:2	WEIGHT:
5	4	3	2	1	SHEET 10 OF 12	

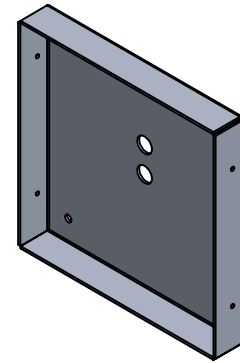
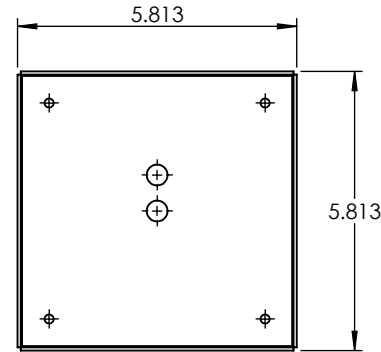
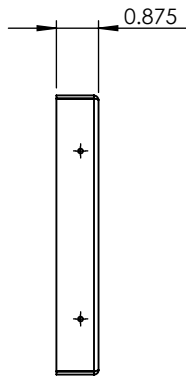
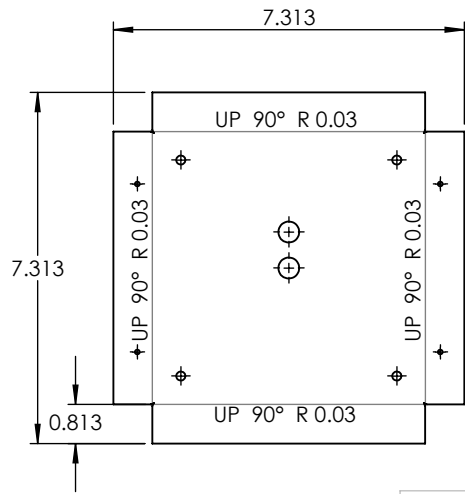
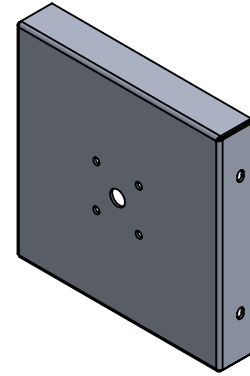
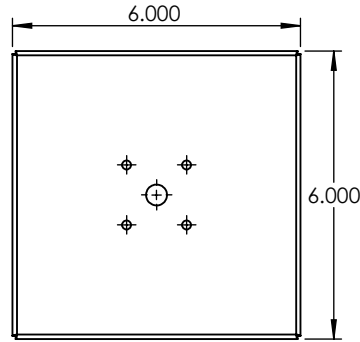
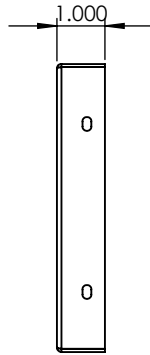
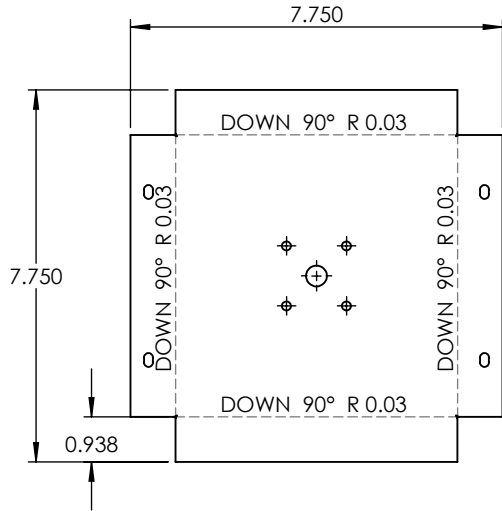

PROPRIETARY AND CONFIDENTIAL
 THE INFORMATION CONTAINED IN THIS DRAWING IS THE SOLE PROPERTY OF <INSERT COMPANY NAME HERE>. ANY REPRODUCTION IN PART OR AS A WHOLE WITHOUT THE WRITTEN PERMISSION OF <INSERT COMPANY NAME HERE> IS PROHIBITED.

		UNLESS OTHERWISE SPECIFIED:	NAME	DATE	ALUMINUM 0.0635"	
		DIMENSIONS ARE IN INCHES TOLERANCES: FRACTIONAL ± ANGULAR: MACH ± BEND ± TWO PLACE DECIMAL ± THREE PLACE DECIMAL ±	DRAWN		TITLE:	
		INTERPRET GEOMETRIC TOLERANCING PER:	CHECKED		CHTRI-2ARM-50W-BA-WF-DIM-WET-35K	
		MATERIAL	ENG APPR.		SIZE DWG. NO. REV	
NEXT ASSY	USED ON	FINISH	MFG APPR.		A	
APPLICATION		DO NOT SCALE DRAWING	Q.A.		SCALE: 1:4	WEIGHT:
			COMMENTS:		SHEET 11 OF 12	

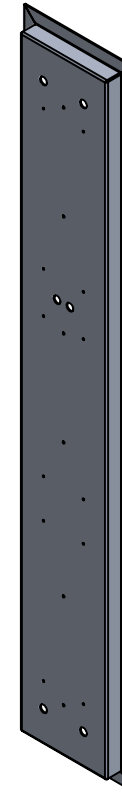
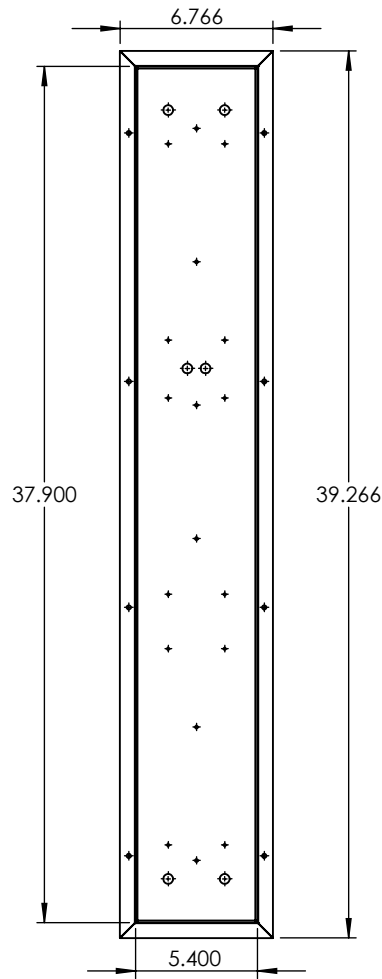
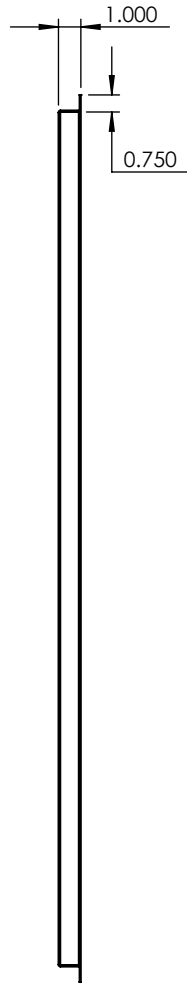
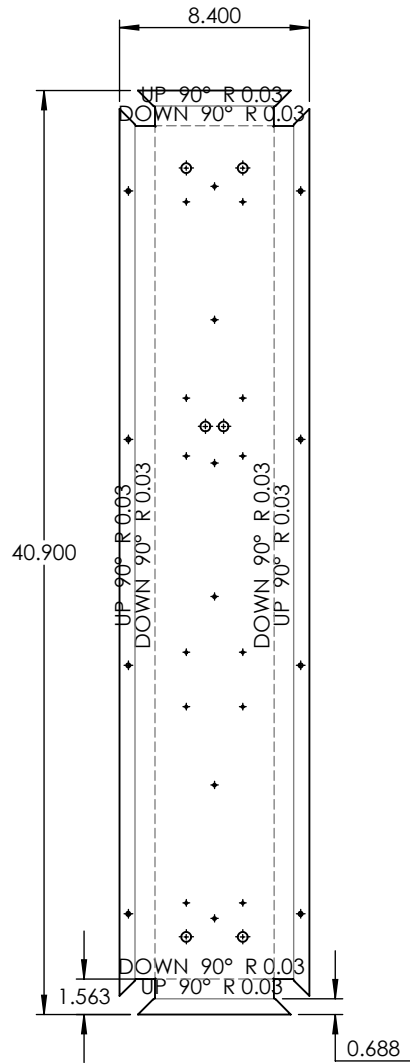

PROPRIETARY AND CONFIDENTIAL
 THE INFORMATION CONTAINED IN THIS DRAWING IS THE SOLE PROPERTY OF <INSERT COMPANY NAME HERE>. ANY REPRODUCTION IN PART OR AS A WHOLE WITHOUT THE WRITTEN PERMISSION OF <INSERT COMPANY NAME HERE> IS PROHIBITED.

		UNLESS OTHERWISE SPECIFIED:	NAME	DATE	ALUMINUM 0.0635"	
		DIMENSIONS ARE IN INCHES	DRAWN		TITLE:	
		TOLERANCES:	CHECKED		CHTRI-2ARM-50W-BA-WF-DIM-WET-35K	
		FRACTIONAL ±	ENG APPR.		SIZE DWG. NO. REV	
		ANGULAR: MACH ± BEND ±	MFG APPR.		SCALE: 1:8.5 WEIGHT: SHEET 12 OF 12	
		TWO PLACE DECIMAL ±	Q.A.			
		THREE PLACE DECIMAL ±	COMMENTS:			
		INTERPRET GEOMETRIC TOLERANCING PER:				
		MATERIAL				
NEXT ASSY	USED ON	FINISH				
APPLICATION		DO NOT SCALE DRAWING				