

ITEM NO.	PART NUMBER	DESCRIPTION	QTY.	CUT
1	DS18-MBK-E1-12W-40K-CAST CANOPY	CAST ALUMINUM	1	
2	DS18-MBK-E1-12W-40K-DOME SHADE	SPUN ALUMINUM 0.080"	1	
3	DS18-MBK-E1-12W-40K-HOUSING DOOR BRACKET	SPUN ALUMINUM 0.080"	1	
4	DS18-MBK-E1-12W-40K-HOUSING DOOR	SPUN ALUMINUM 0.080"	1	
5	DS18-MBK-E1-12W-40K-MOUNTING BRACKET	ALUMINUM 0.0635"	1	
6	DS18-MBK-E1-12W-40K-SPACER BRACKET	ALUMINUM 0.0635"	1	
7	DS18-MBK-E1-12W-40K-ROUND LED PLATE	ALUMINUM 0.0635"	1	
8	DS18-MBK-E1-12W-40K-0.250" NUT	ALUMINUM 0.250" PLATE	1	
9	DS18-MBK-E1-12W-40K-E1 ARM TUBE	7/8" ALUMINUM TUBE	1	
10	DS18-MBK-E1-12W-40K-ACRYLIC LENS	ACRYLIC	1	
11	55MM HEXAGON HEAT SINK	HEAT SINK	1	
12	DS-15W-350C1542010-3001	DRIVER	1	
13	Alttailed_PCN_D1500_110B-10 WATT	LED	1	

UNLESS OTHERWISE SPECIFIED:

DIMENSIONS ARE IN INCHES  
 TOLERANCES:  
 FRACTIONAL ± .003  
 ANGULAR: MACH ± .01 BEND ±  
 TWO PLACE DECIMAL ±  
 THREE PLACE DECIMAL ±.001

INTERPRET GEOMETRIC  
 TOLERANCING PER:

MATERIAL

FINISH

	NAME	DATE
DRAWN		
CHECKED		
ENG APPR.		
MFG APPR.		
Q.A.		
COMMENTS:		

TITLE:

DS18-GBK-E1-12W-35K

SIZE	DWG. NO.	REV
<b>A</b>	TICKET 27451	
SCALE: 1:10	WEIGHT:	SHEET 1 OF 8



ALL BEND RADIUS .030"

APPLICATION

DO NOT SCALE DRAWING

5

4

3

2

1

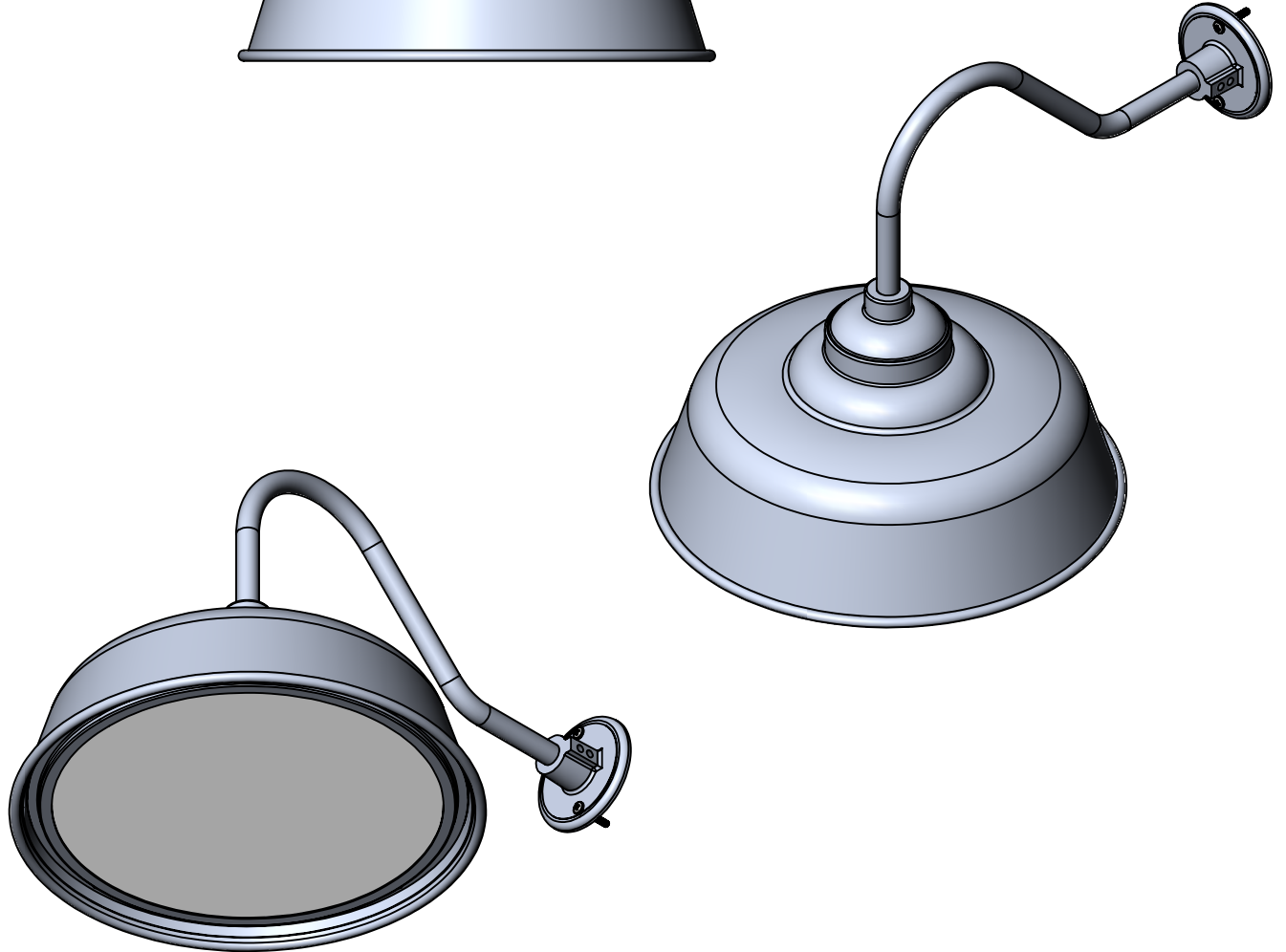
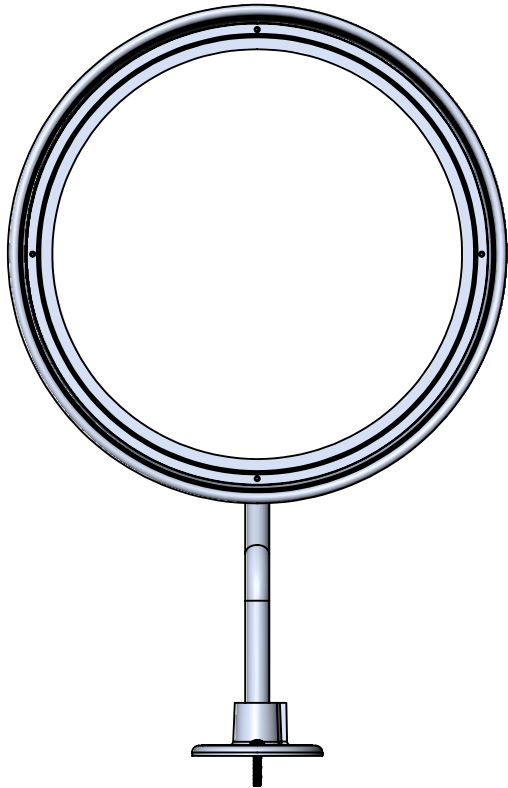
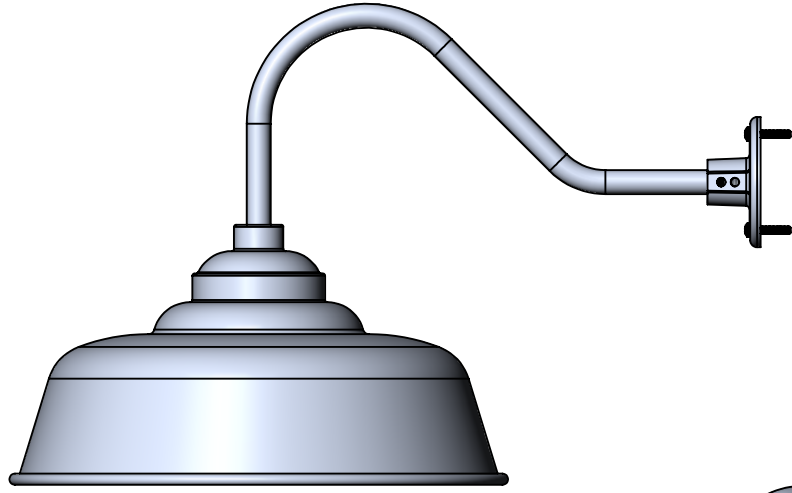
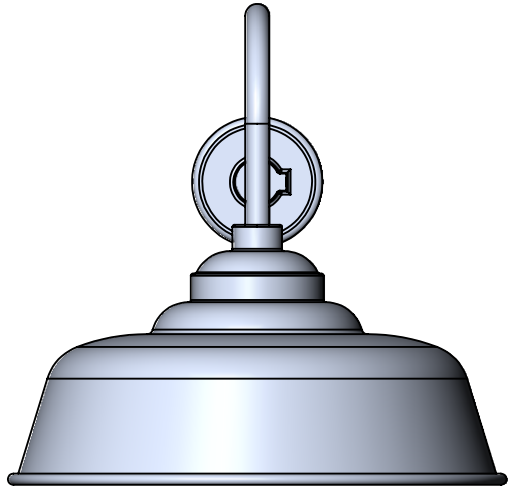

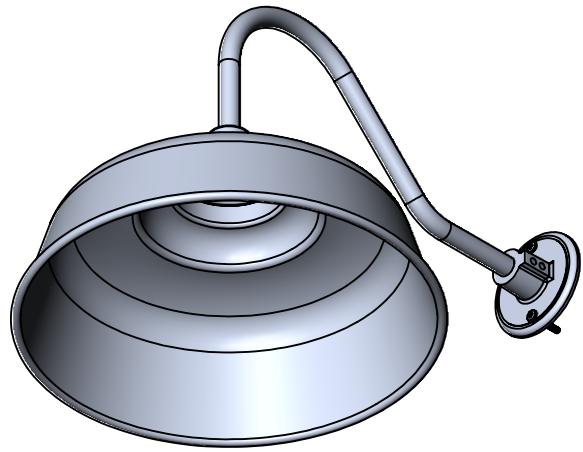

**MOUNTING  
BRACKET**

**DOOR BRACKET**

**MOUNTING BRACKET WELDED  
INSIDE OF SPUN HOUSING**

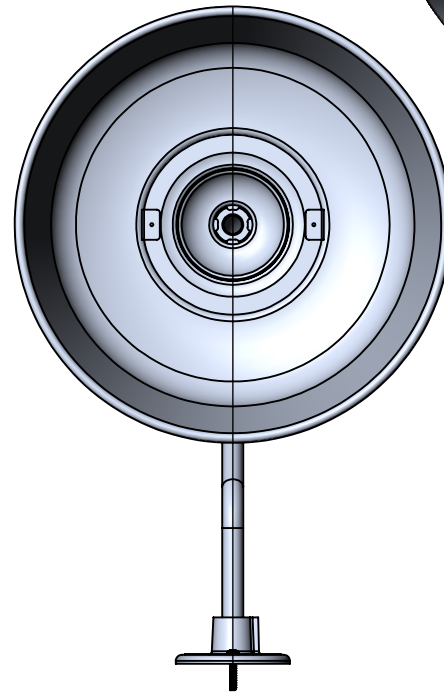

**ALUMINUM NUT**

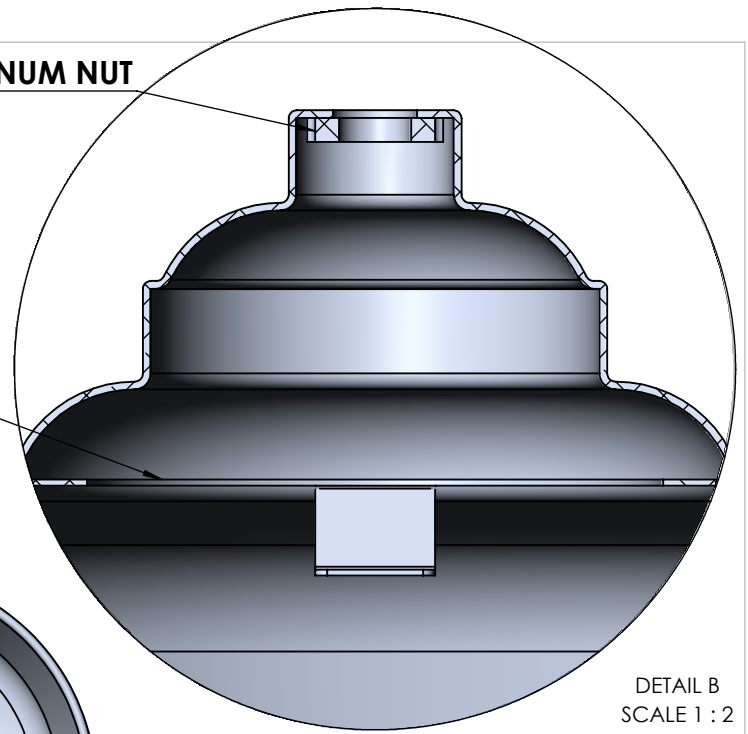

**DETAIL B  
SCALE 1 : 2**

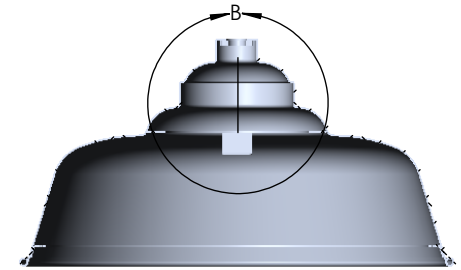

**SECTION A-A**

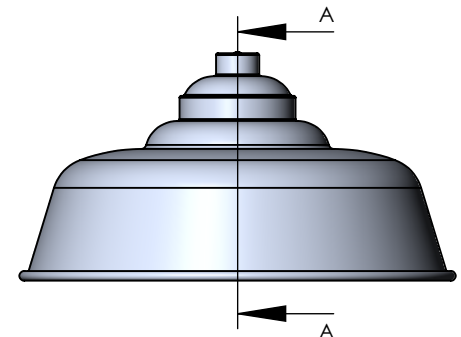

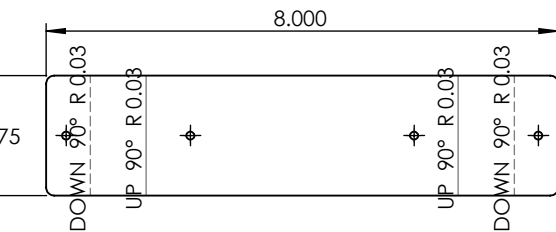
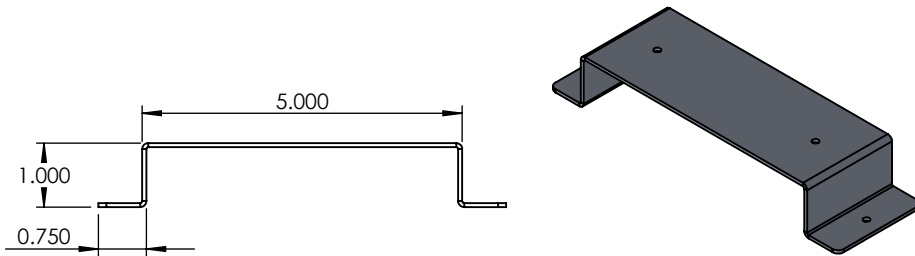
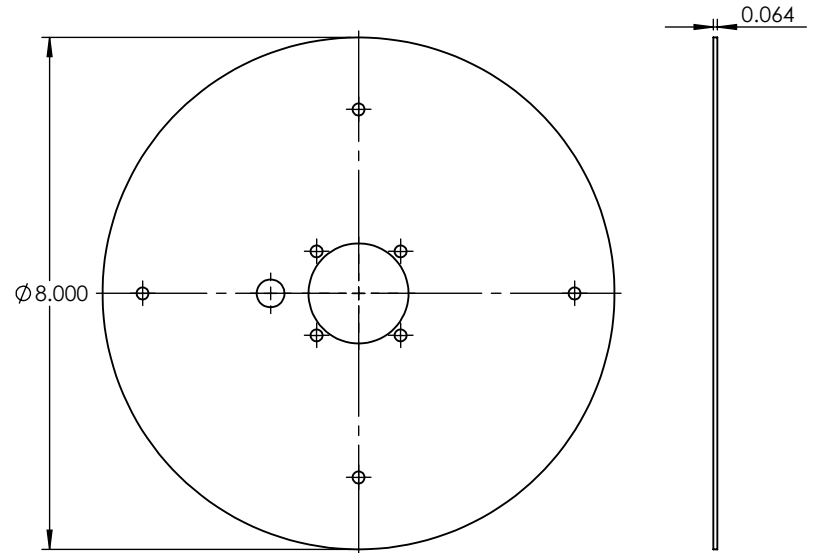
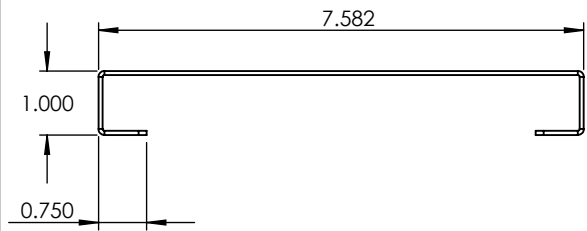
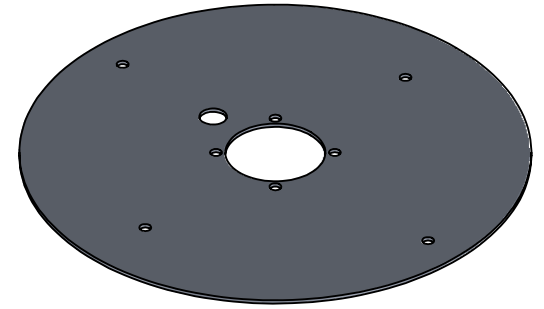
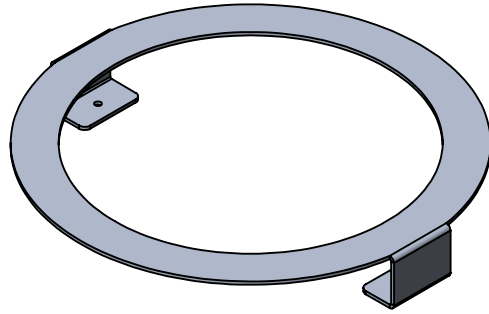
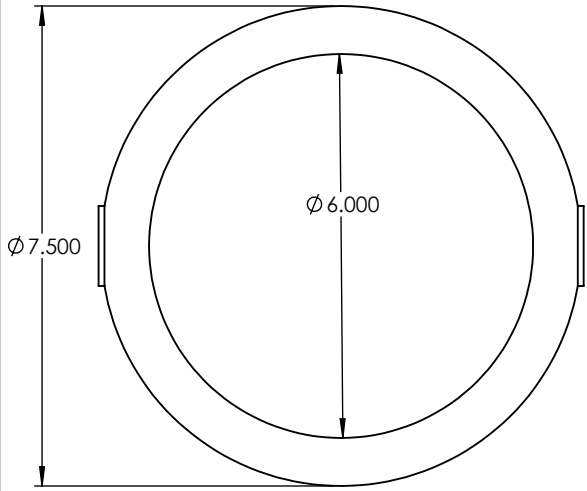

UNLESS OTHERWISE SPECIFIED:

DIMENSIONS ARE IN INCHES  
 TOLERANCES:  
 FRACTIONAL ±  
 ANGULAR: MACH ± BEND ±  
 TWO PLACE DECIMAL ±  
 THREE PLACE DECIMAL ±

INTERPRET GEOMETRIC  
 TOLERANCING PER:

MATERIAL

FINISH

DO NOT SCALE DRAWING

NAME

DATE

DRAWN

CHECKED

ENG APPR.

MFG APPR.

Q.A.

COMMENTS:

ALUMINUM 0.0635"

TITLE:

DS18-GBK-E1-12W-35K

SIZE  
**A**

DWG. NO.

REV

SCALE: 1:3

WEIGHT:

SHEET 4 OF 8

**PROPRIETARY AND CONFIDENTIAL**

THE INFORMATION CONTAINED IN THIS DRAWING IS THE SOLE PROPERTY OF <INSERT COMPANY NAME HERE>. ANY REPRODUCTION IN PART OR AS A WHOLE WITHOUT THE WRITTEN PERMISSION OF <INSERT COMPANY NAME HERE> IS PROHIBITED.

NEXT ASSY	USED ON
APPLICATION	

5

4

3

2

1

TOTAL TUBE LENGTH IS 26" INCLUDING THREADED LENGTHS

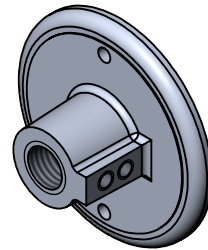
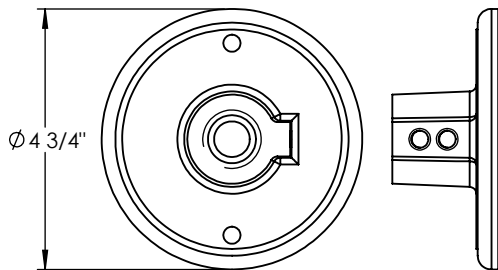
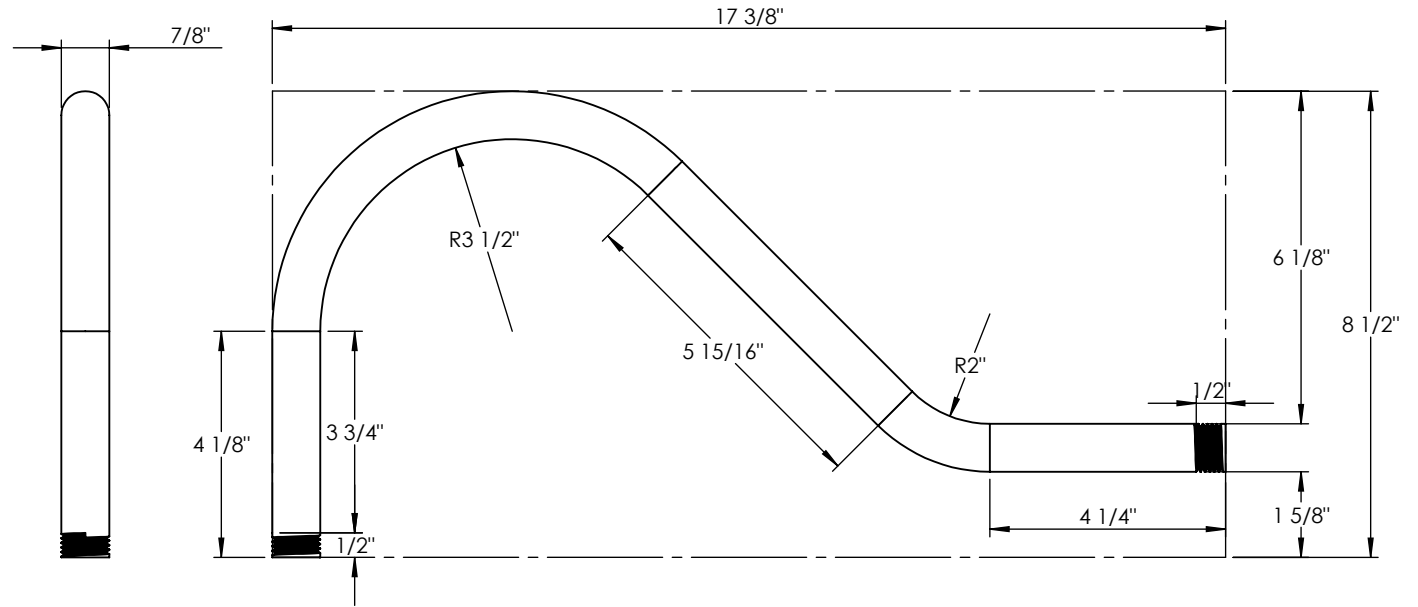
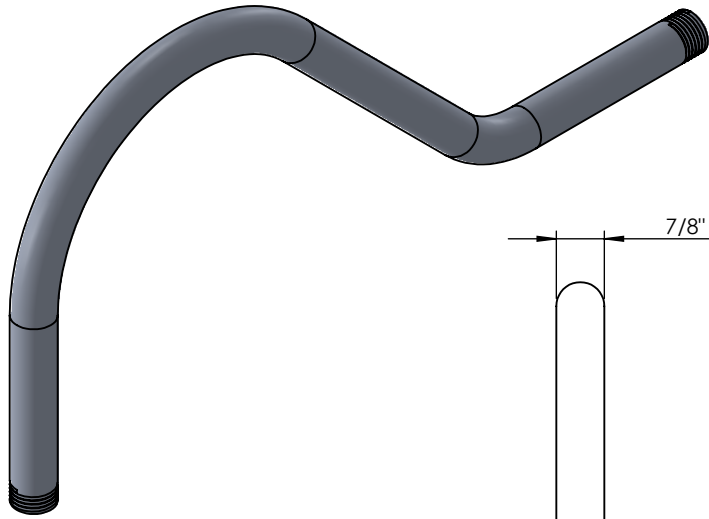

UNLESS OTHERWISE SPECIFIED:

DIMENSIONS ARE IN INCHES  
 TOLERANCES:  
 FRACTIONAL ±  
 ANGULAR: MACH ± BEND ±  
 TWO PLACE DECIMAL ±  
 THREE PLACE DECIMAL ±

INTERPRET GEOMETRIC  
 TOLERANCING PER:

MATERIAL

FINISH

DO NOT SCALE DRAWING

	NAME	DATE
DRAWN		
CHECKED		
ENG APPR.		
MFG APPR.		
Q.A.		
COMMENTS:		

7/8" ALUMINUM TUBE

TITLE:

DS18-GBK-E1-12W-35K

SIZE	DWG. NO.	REV
<b>A</b>		
SCALE: 1:3.5	WEIGHT:	SHEET 5 OF 8

**PROPRIETARY AND CONFIDENTIAL**  
 THE INFORMATION CONTAINED IN THIS  
 DRAWING IS THE SOLE PROPERTY OF  
 <INSERT COMPANY NAME HERE>. ANY  
 REPRODUCTION IN PART OR AS A WHOLE  
 WITHOUT THE WRITTEN PERMISSION OF  
 <INSERT COMPANY NAME HERE> IS  
 PROHIBITED.

NEXT ASSY	USED ON	APPLICATION

ITEM NO.	PART NUMBER	DESCRIPTION	QTY.
1	DS18-MBK-E1-12W-40K-CAST CANOPY	CAST ALUMINUM	1

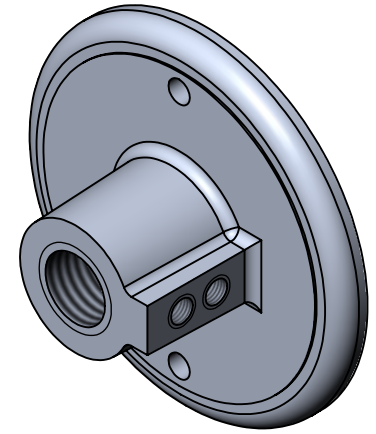
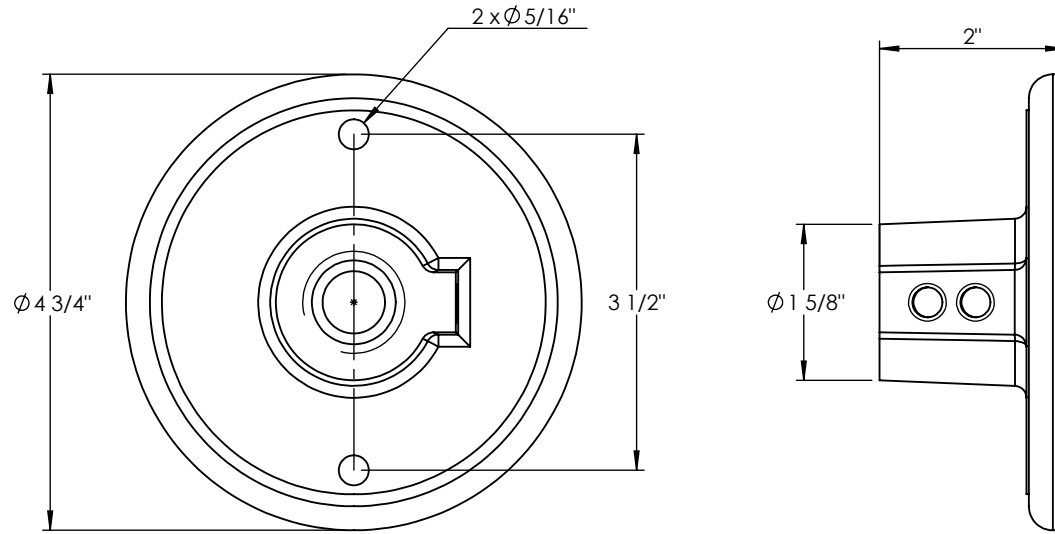

**PROPRIETARY AND CONFIDENTIAL**  
 THE INFORMATION CONTAINED IN THIS DRAWING IS THE SOLE PROPERTY OF <INSERT COMPANY NAME HERE>. ANY REPRODUCTION IN PART OR AS A WHOLE WITHOUT THE WRITTEN PERMISSION OF <INSERT COMPANY NAME HERE> IS PROHIBITED.

		UNLESS OTHERWISE SPECIFIED:		NAME	DATE	CAST ALUMINUM	
		DIMENSIONS ARE IN INCHES		DRAWN		TITLE:	
		TOLERANCES:		CHECKED		DS18-GBK-E1-12W-35K	
		FRACTIONAL ±		ENG APPR.		SIZE	DWG. NO.
		ANGULAR: MACH ± BEND ±		MFG APPR.		<b>A</b>	
		TWO PLACE DECIMAL ±		Q.A.		SCALE: 1:2	WEIGHT:
		THREE PLACE DECIMAL ±		COMMENTS:			SHEET 6 OF 8
		INTERPRET GEOMETRIC TOLERANCING PER:					
		MATERIAL					
	NEXT ASSY	USED ON					
		FINISH					
	APPLICATION	DO NOT SCALE DRAWING					

5

4

3

2

1

ITEM NO.	PART NUMBER	DESCRIPTION	QTY.
1	DS18-MBK-E1-12W-40K-DOME SHADE	SPUN ALUMINUM 0.080"	1

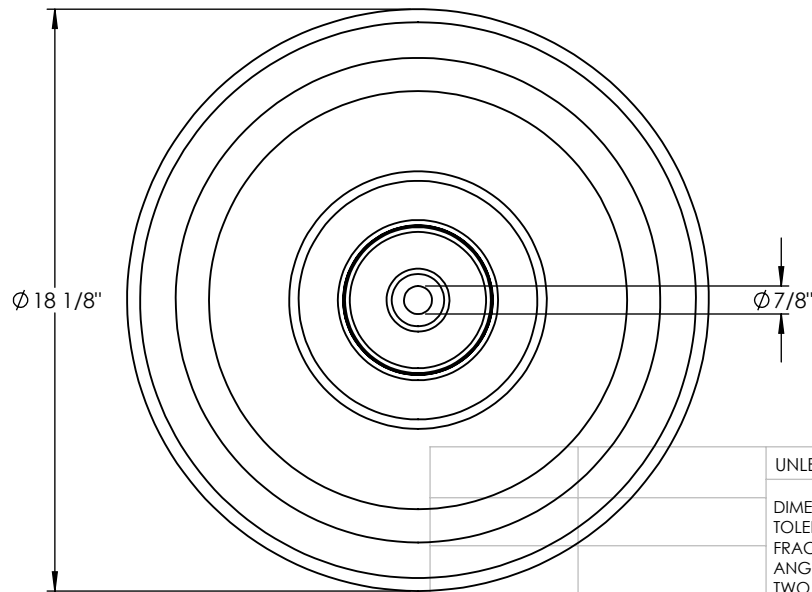
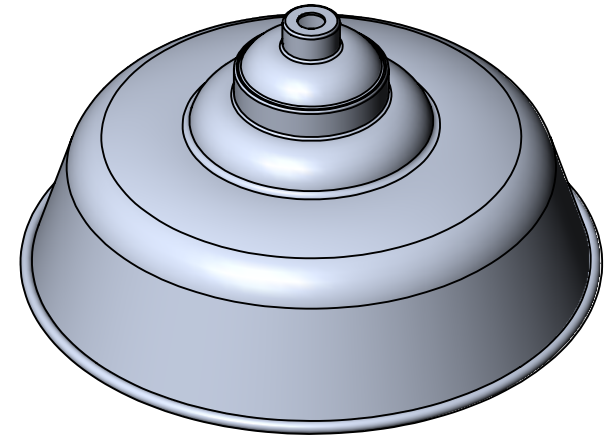
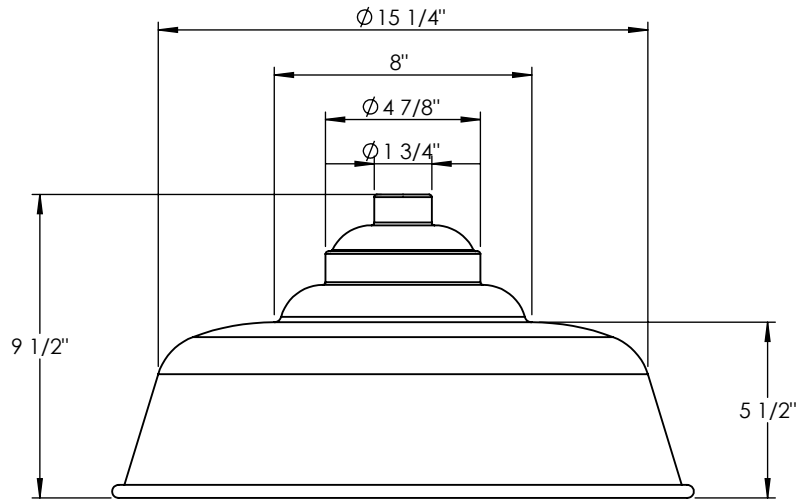

**PROPRIETARY AND CONFIDENTIAL**  
 THE INFORMATION CONTAINED IN THIS DRAWING IS THE SOLE PROPERTY OF <INSERT COMPANY NAME HERE>. ANY REPRODUCTION IN PART OR AS A WHOLE WITHOUT THE WRITTEN PERMISSION OF <INSERT COMPANY NAME HERE> IS PROHIBITED.

UNLESS OTHERWISE SPECIFIED:		NAME	DATE
DIMENSIONS ARE IN INCHES		DRAWN	
TOLERANCES:		CHECKED	
FRACTIONAL ±		ENG APPR.	
ANGULAR: MACH ± BEND ±		MFG APPR.	
TWO PLACE DECIMAL ±		Q.A.	
THREE PLACE DECIMAL ±		COMMENTS:	
INTERPRET GEOMETRIC TOLERANCING PER:			
MATERIAL			
FINISH			
NEXT ASSY	USED ON		
APPLICATION	DO NOT SCALE DRAWING		

TITLE:		
SPUN ALUMINUM 0.080"		
DS18-GBK-E1-12W-35K		
SIZE	DWG. NO.	REV
<b>A</b>		
SCALE: 1:6	WEIGHT:	SHEET 7 OF 8

ITEM NO.	PART NUMBER	DESCRIPTION	QTY.
1	DS18-MBK-E1-12W-40K-HOUSING DOOR BRACKET	SPUN ALUMINUM 0.080"	1

ITEM NO.	PART NUMBER	DESCRIPTION	QTY.
1	DS18-MBK-E1-12W-40K-HOUSING DOOR	SPUN ALUMINUM 0.080"	1

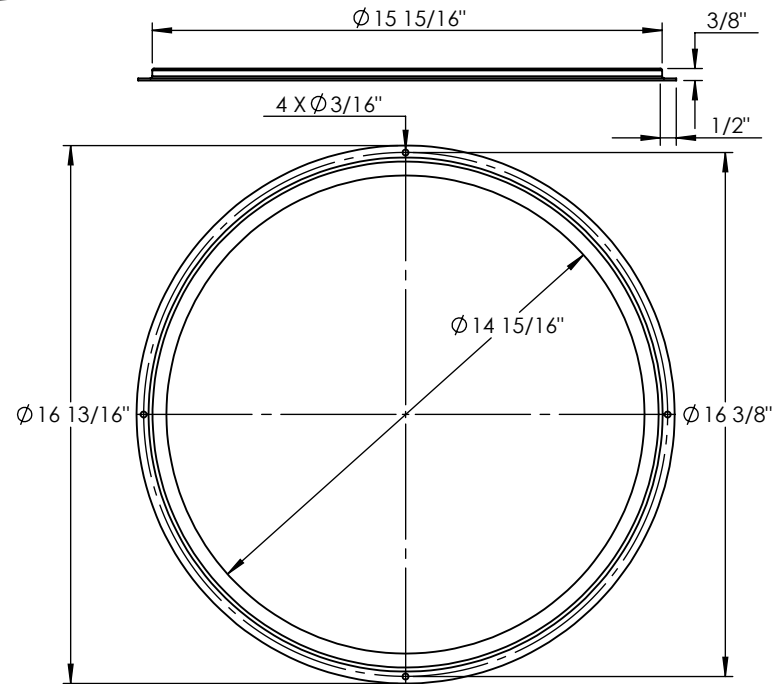
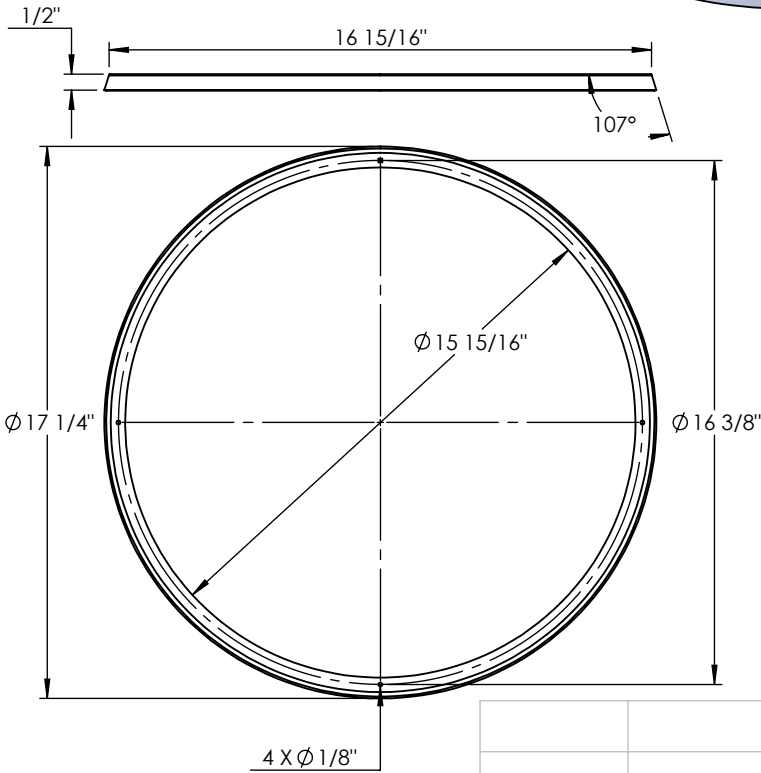
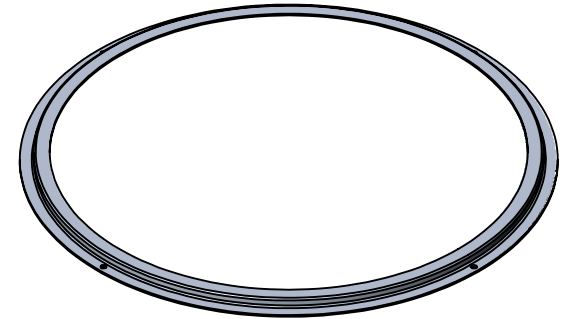
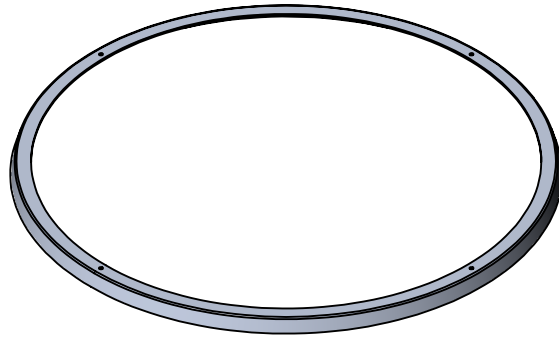

**PROPRIETARY AND CONFIDENTIAL**  
 THE INFORMATION CONTAINED IN THIS DRAWING IS THE SOLE PROPERTY OF <INSERT COMPANY NAME HERE>. ANY REPRODUCTION IN PART OR AS A WHOLE WITHOUT THE WRITTEN PERMISSION OF <INSERT COMPANY NAME HERE> IS PROHIBITED.

UNLESS OTHERWISE SPECIFIED:		NAME	DATE
DIMENSIONS ARE IN INCHES		DRAWN	
TOLERANCES:		CHECKED	
FRACTIONAL ±		ENG APPR.	
ANGULAR: MACH ± BEND ±		MFG APPR.	
TWO PLACE DECIMAL ±		Q.A.	
THREE PLACE DECIMAL ±		COMMENTS:	
INTERPRET GEOMETRIC TOLERANCING PER:			
MATERIAL			
FINISH			
NEXT ASSY	USED ON		
APPLICATION	DO NOT SCALE DRAWING		

SPUN ALUMINUM 0.080"		
TITLE:		
DS18-GBK-E1-12W-35K		
SIZE	DWG. NO.	REV
<b>A</b>		
SCALE: 1:6	WEIGHT:	SHEET 8 OF 8