

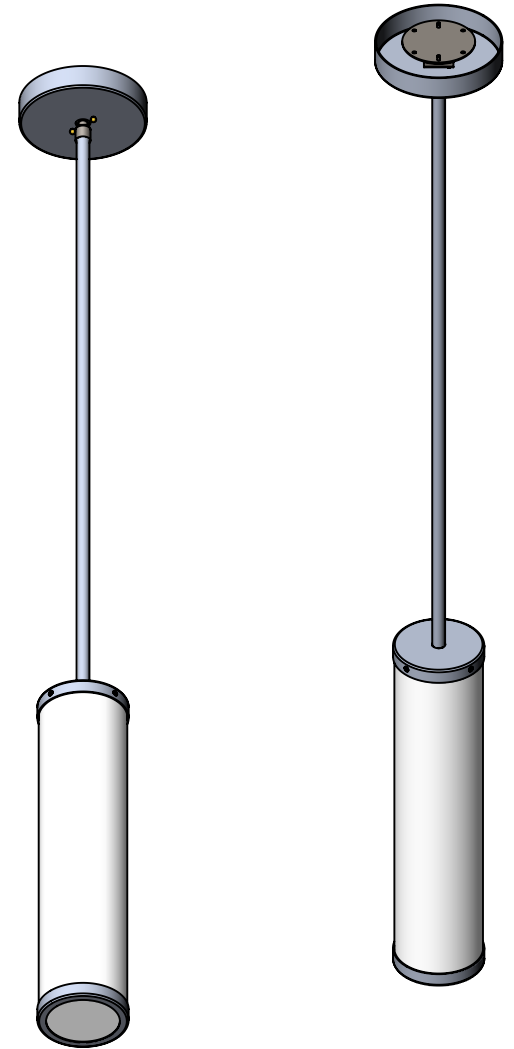

EVERGREEN LIGHTING

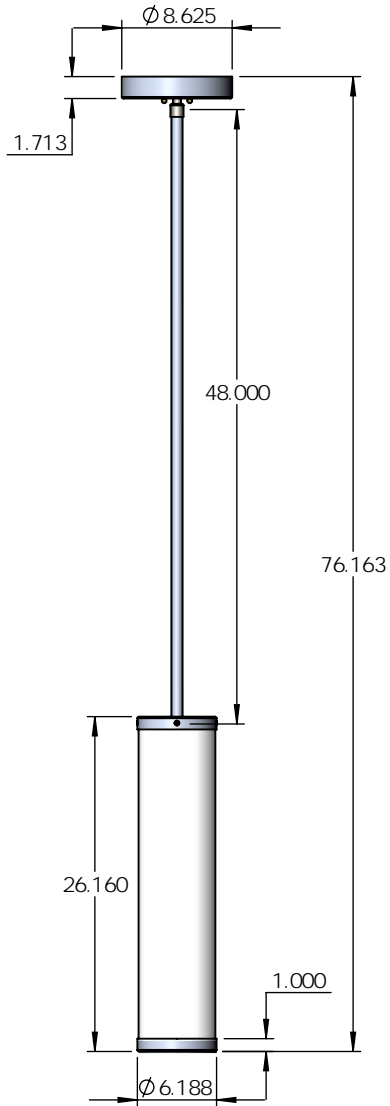
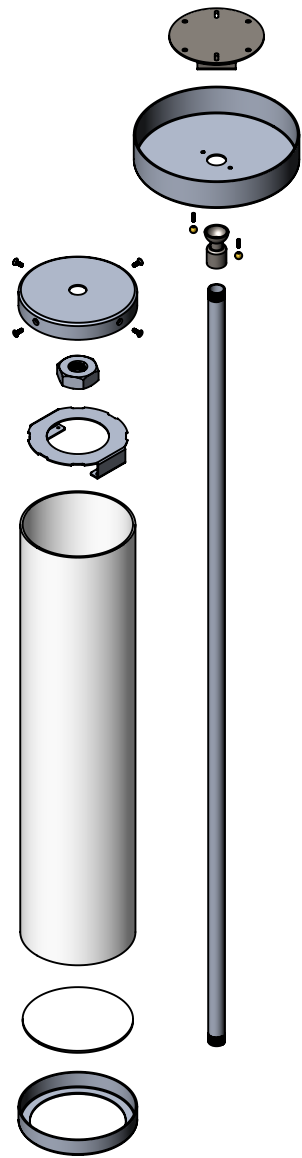

UNLESS OTHERWISE SPECIFIED:		NAME	DATE		
DIMENSIONS ARE IN INCHES TOLERANCES: FRACTIONAL $\pm .003$ ANGULAR: MACH $\pm .01$ BEND \pm TWO PLACE DECIMAL \pm THREE PLACE DECIMAL $\pm .001$		DRAWN		TITLE:	
INTERPRET GEOMETRIC TOLERANCING PER:		CHECKED		ACP-LA-S-SR-6-26-40W-MN-WF-DIM-27K	
MATERIAL		ENG APPR.			
FINISH		MFG APPR.		SIZE	DWG. NO.
APPLICATION		Q.A.		A	REV
DO NOT SCALE DRAWING		COMMENTS:			SCALE: 1:10
5	4	3	2	SHEET 1 OF 11	

5

4

3

2

1

ITEM NO.	PART NUMBER	DESCRIPTION	QTY.	CUT
1	8" SWIVEL CANOPY	SPUN ALUMINUM 0.080"	1	
2	ACP-LA-S-SR-6-26-40W-MN-WF-DIM-27K-SPUN TOP CAP	SPUN ALUMINUM 0.080"	1	
3	ACP-LA-S-SR-6-26-40W-MN-WF-DIM-27K-SPUN BOTTOM CAP	SPUN ALUMINUM 0.080"	1	
4	SWIVEL BRACKET	SWIVEL BRACKET	1	
5	SWIVEL	SWIVEL	1	
6	.375 BRASS BALL	3/8" BRASS BALL	2	
7	ACP-LA-S-SR-6-26-40W-MN-WF-DIM-27K-0.875" STEM TUBE	7/8" ROUND ALUMINUM TUBE	1	
8	ACP-LA-S-SR-6-26-40W-MN-WF-DIM-27K-SQUARE LED TUBE	1" SQUARE ALUMINUM TUBE	1	
9	ACP-LA-S-SR-6-26-40W-MN-WF-DIM-27K-REFLECTOR BRACKET	ALUMINUM 0.0635"	1	
10	ACP-LA-S-SR-6-26-40W-MN-WF-DIM-27K-REFLECTOR PLATE	ALUMINUM 0.125" PLATE	1	
11	ACP-LA-S-SR-6-26-40W-MN-WF-DIM-27K-ACRYLIC TUBE	ACRYLIC	1	
12	ACP-LA-S-SR-6-26-40W-MN-WF-DIM-27K-ACRYLIC PLATE	ACRYLIC	1	
13	8-32-0.5 SS Hex Drive Flat Head	8-32 FLAT HEAD SCREW	4	
14	AltaLED PN105B-11-2.5-SS	LED	8	
15	AC25CD700A T20 LED DRIVER	DRIVER	2	
16	92949A 194	8-32 HEAD SCREW	4	
17	90670A 270	ALUMINUM HEX NUT	1	
18	93225A 571	THREADED STUD	2	

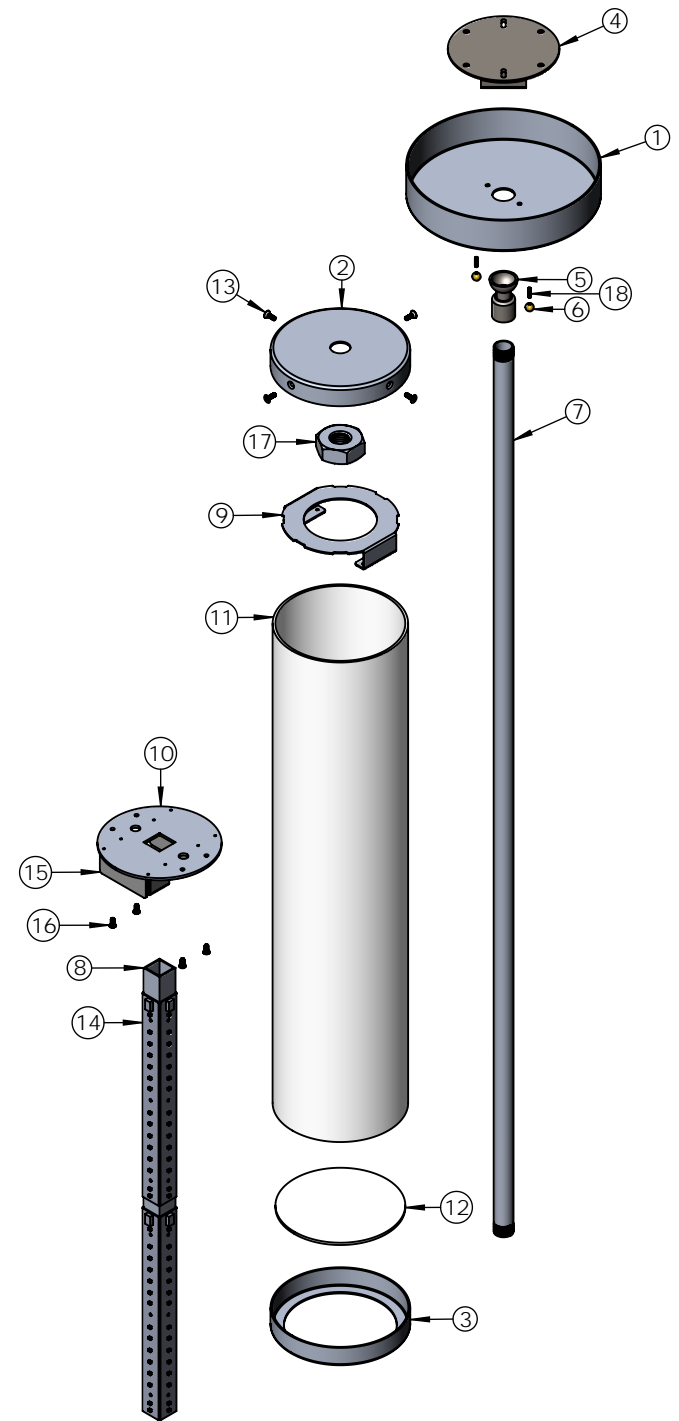

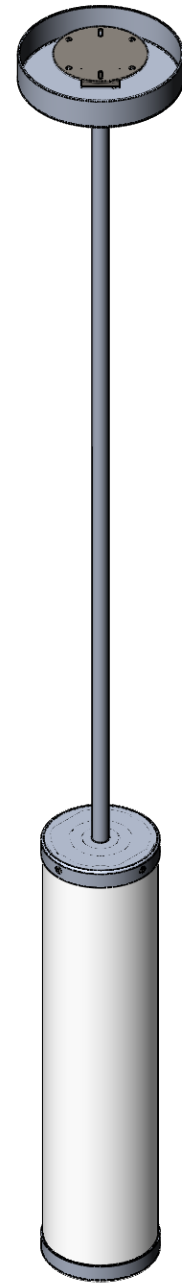
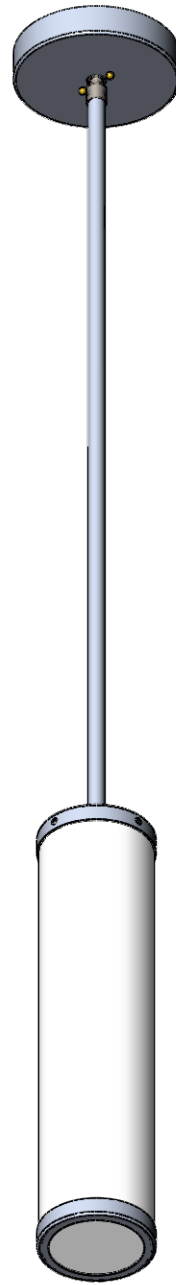
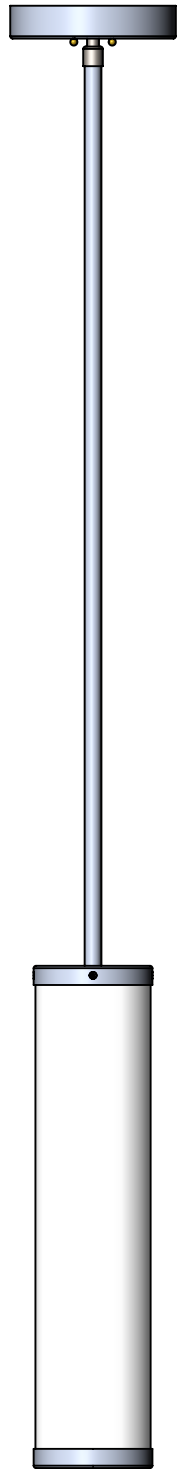

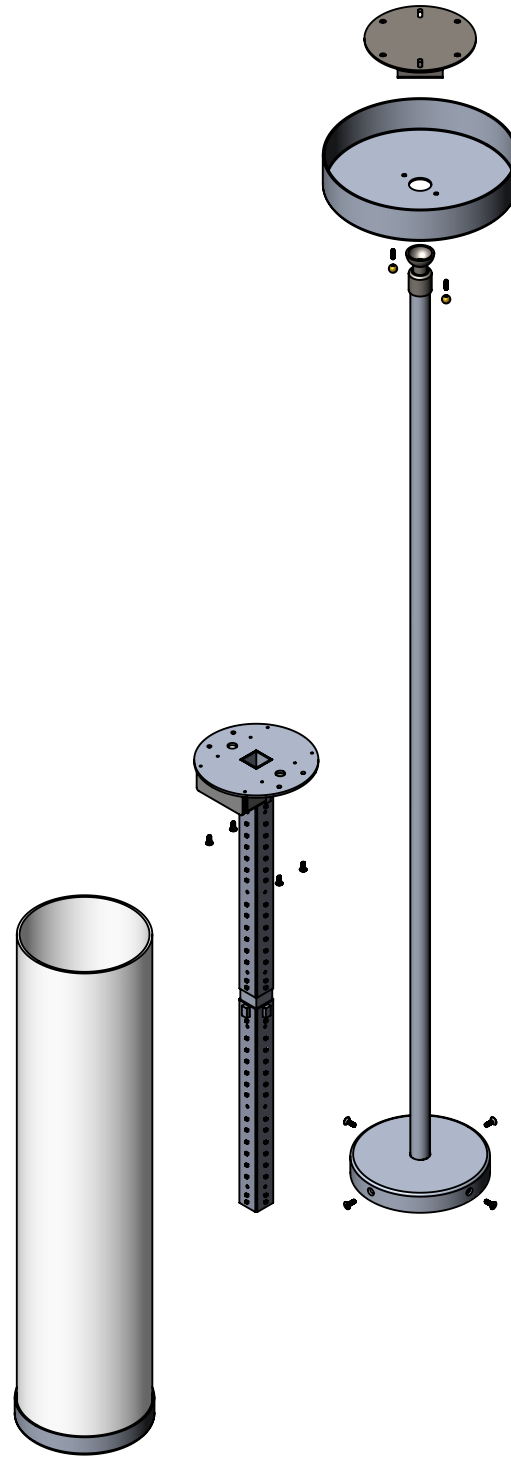
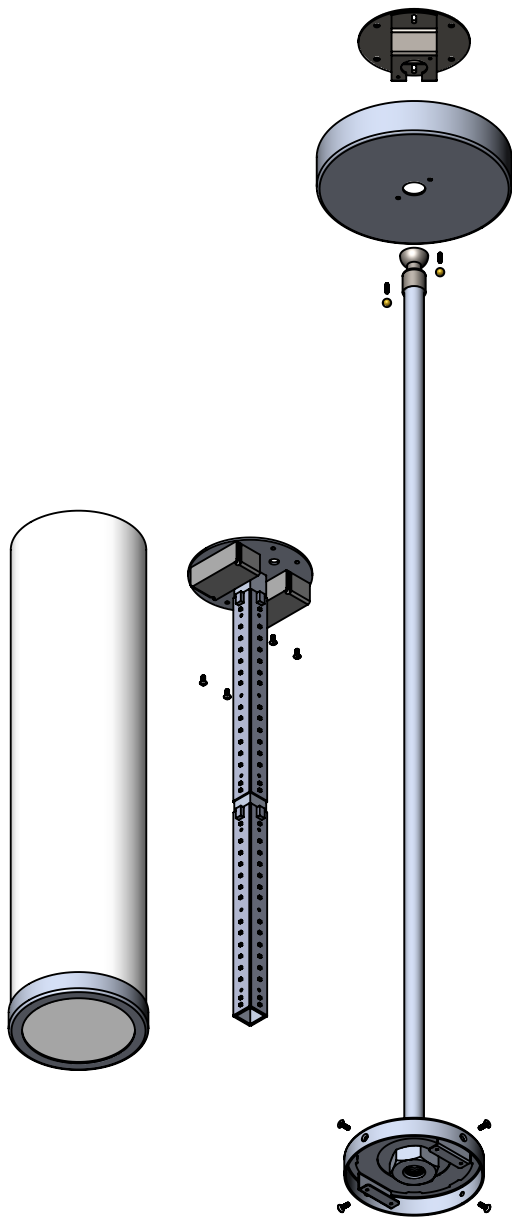

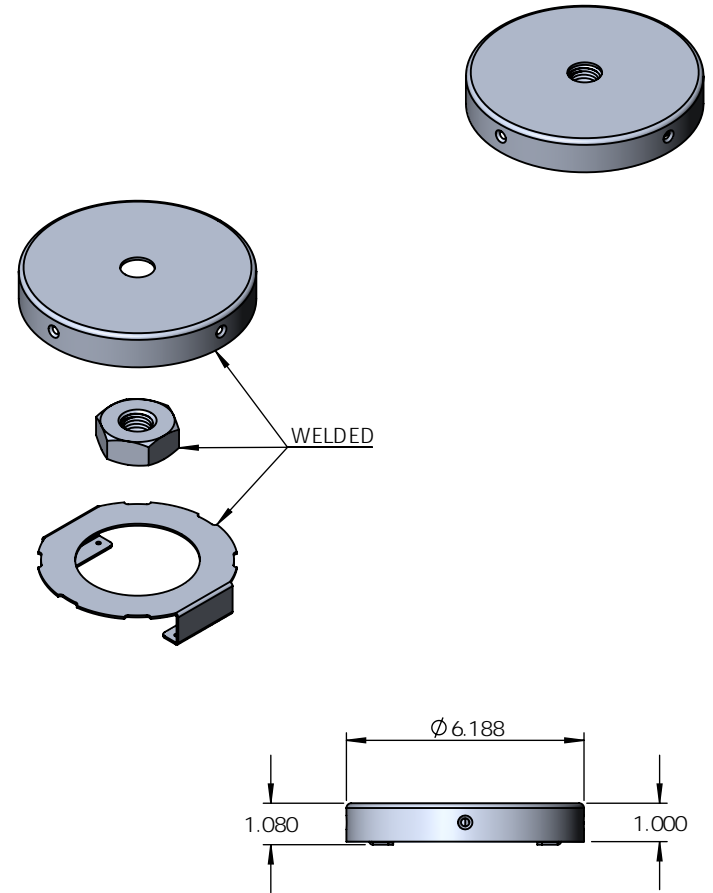
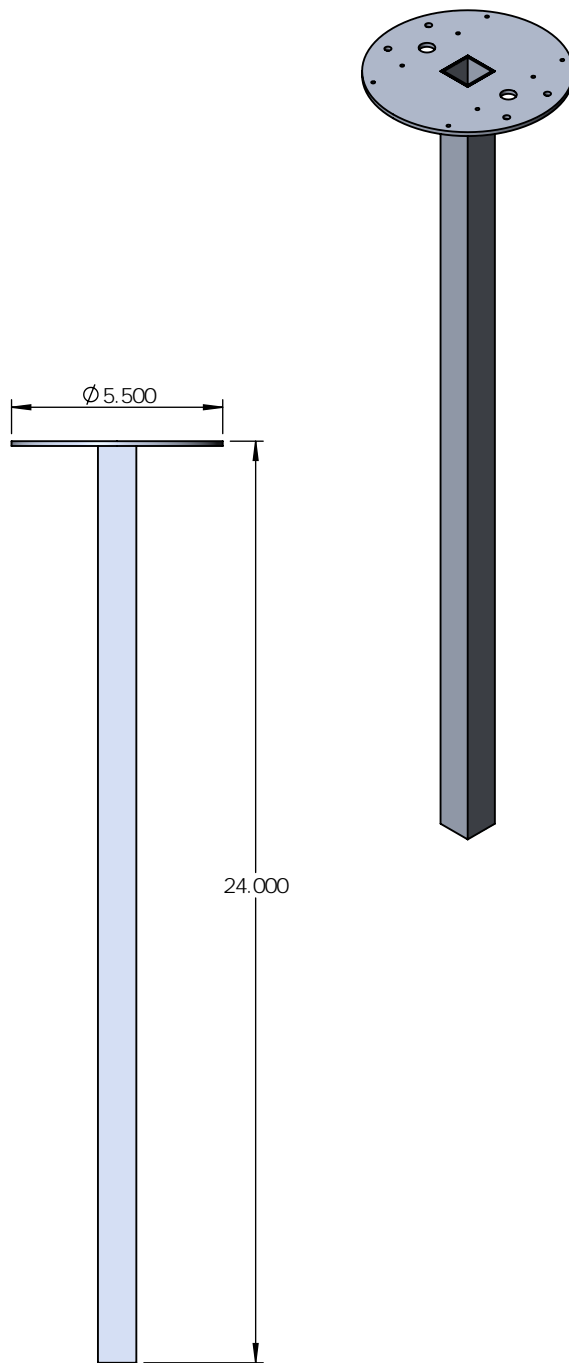
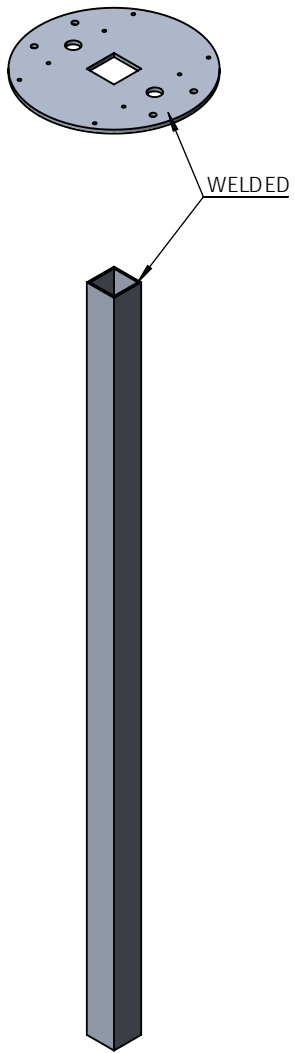

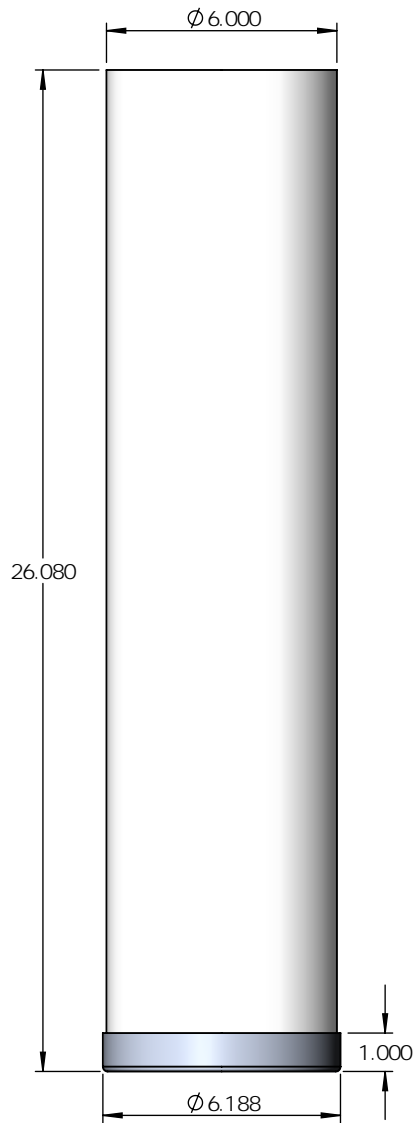

GLUED

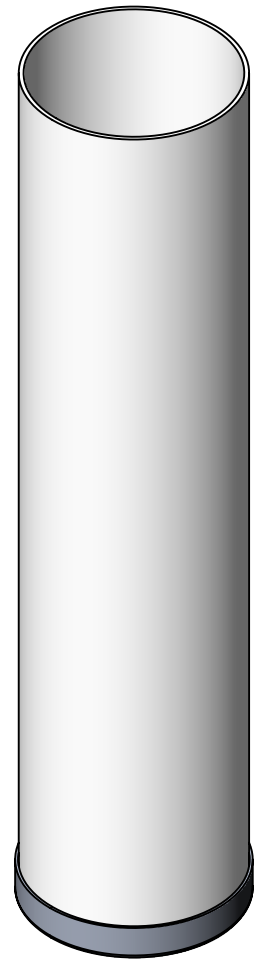
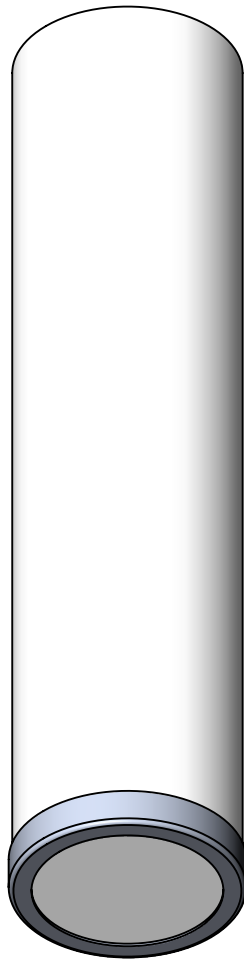
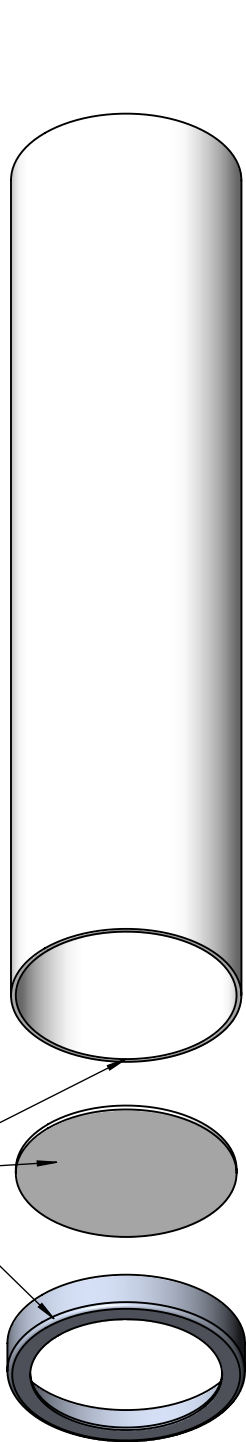

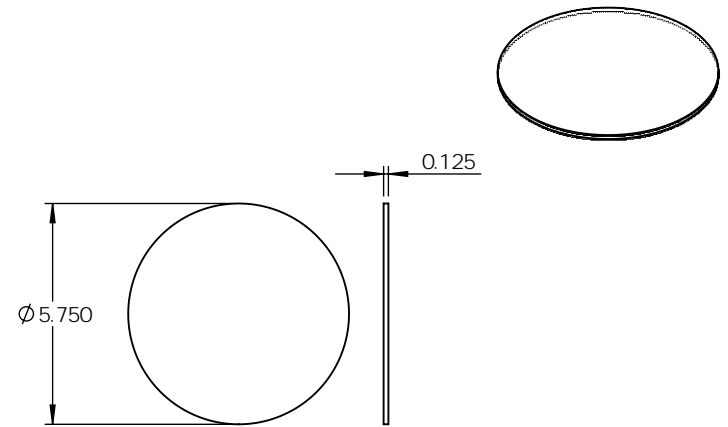
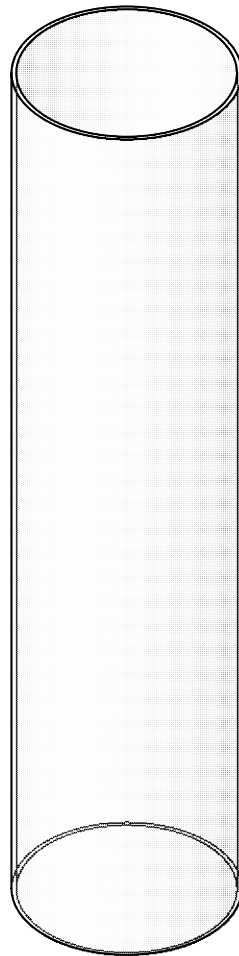
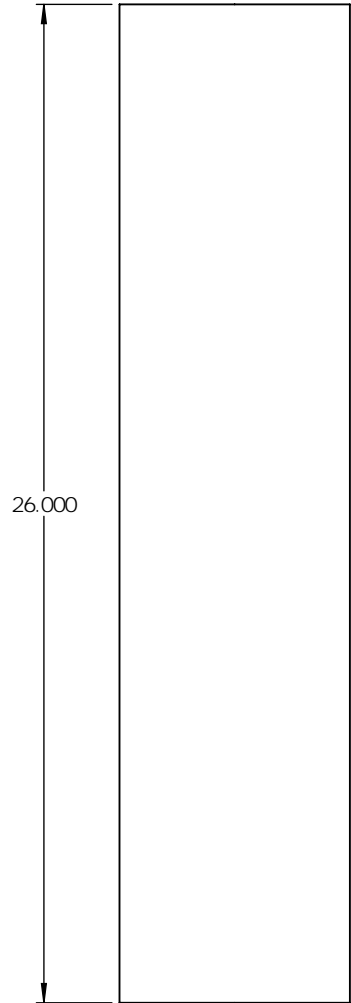
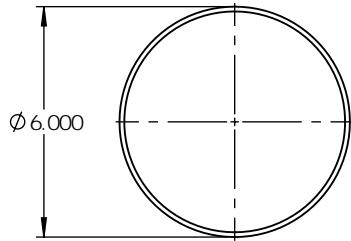

PROPRIETARY AND CONFIDENTIAL
 THE INFORMATION CONTAINED IN THIS DRAWING IS THE SOLE PROPERTY OF <INSERT COMPANY NAME HERE>. ANY REPRODUCTION IN PART OR AS A WHOLE WITHOUT THE WRITTEN PERMISSION OF <INSERT COMPANY NAME HERE> IS PROHIBITED.

NEXT ASSY	USED ON
APPLICATION	

UNLESS OTHERWISE SPECIFIED:
DIMENSIONS ARE IN INCHES TOLERANCES: FRACTIONAL ± ANGULAR: MACH ± BEND ± TWO PLACE DECIMAL ± THREE PLACE DECIMAL ±
INTERPRET GEOMETRIC TOLERANCING PER:
MATERIAL
FINISH
DO NOT SCALE DRAWING

	NAME	DATE
DRAWN		
CHECKED		
ENG APPR.		
MFG APPR.		
Q.A.		
COMMENTS:		

ACRYLIC		
TITLE:		
ACP-LA-S-SR-6-26-40W-MN-WF-DIM-27K		
SIZE	DWG. NO.	REV
A		
SCALE: 1:5	WEIGHT:	SHEET 7 OF 11

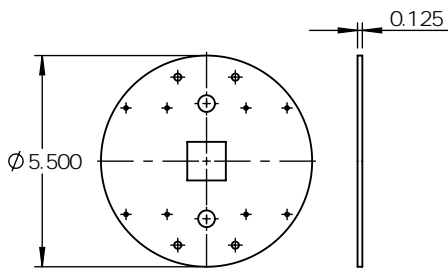
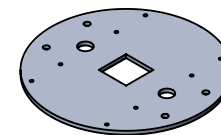
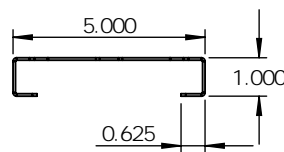
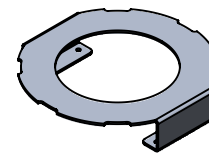
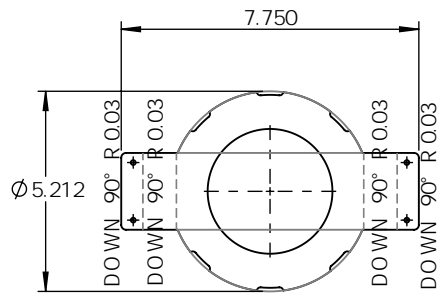
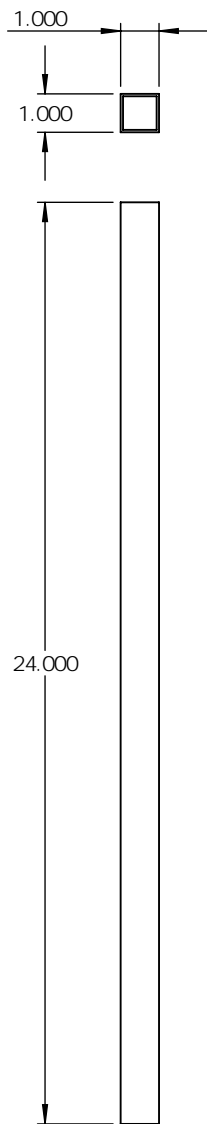

PROPRIETARY AND CONFIDENTIAL
 THE INFORMATION CONTAINED IN THIS DRAWING IS THE SOLE PROPERTY OF <INSERT COMPANY NAME HERE>. ANY REPRODUCTION IN PART OR AS A WHOLE WITHOUT THE WRITTEN PERMISSION OF <INSERT COMPANY NAME HERE> IS PROHIBITED.

		UNLESS OTHERWISE SPECIFIED:	NAME	DATE
		DIMENSIONS ARE IN INCHES TOLERANCES: FRACTIONAL ± ANGULAR: MACH ± BEND ± TWO PLACE DECIMAL ± THREE PLACE DECIMAL ±	DRAWN	
		INTERPRET GEOMETRIC TOLERANCING PER:	CHECKED	
		MATERIAL	ENG APPR.	
		FINISH	MFG APPR.	
NEXT ASSY	USED ON		Q.A.	
APPLICATION	DO NOT SCALE DRAWING		COMMENTS:	

A LUMINUM 0.0635"		
TITLE:		
A C P-LA -S-SR-6-26-40W-MN-WF-DIM-27K		
SIZE	DWG. NO.	REV
A		
SCALE: 1:5	WEIGHT:	SHEET 8 OF 11

ITEM NO.	PART NUMBER	DESCRIPTION	QTY.
1	8" SWIVEL CANOPY	SPUN ALUMINUM 0.080"	1

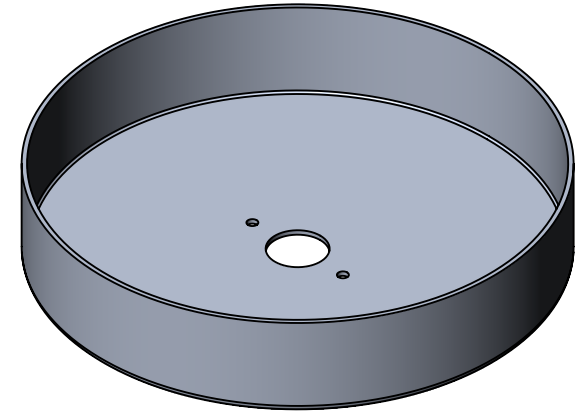
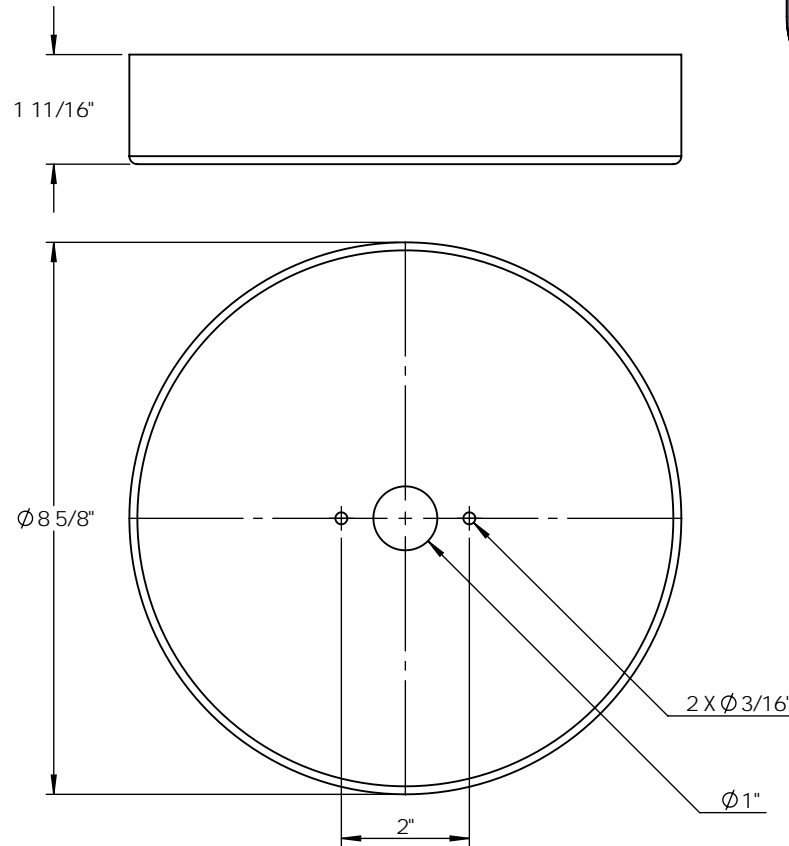
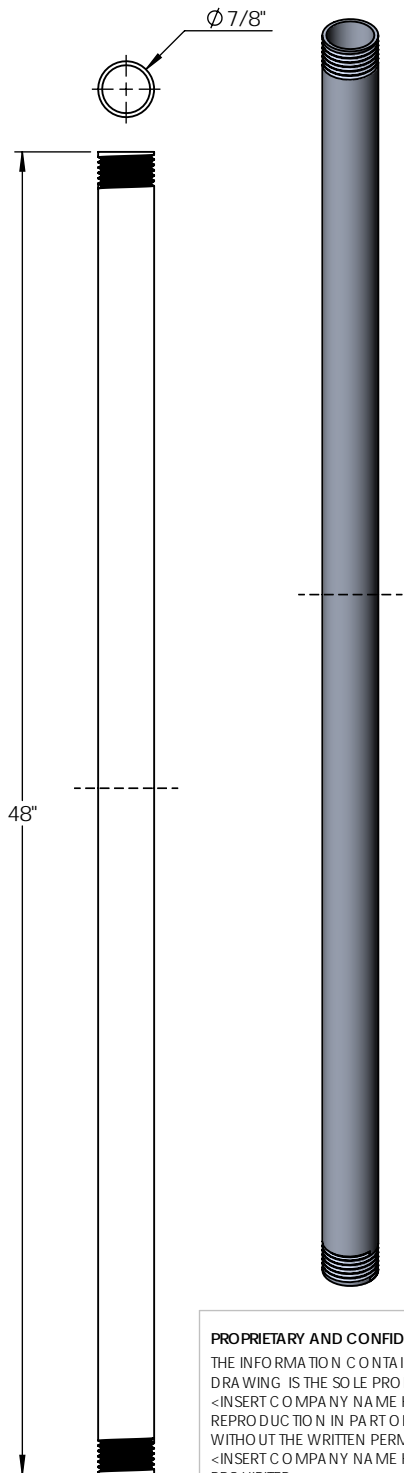

PROPRIETARY AND CONFIDENTIAL
 THE INFORMATION CONTAINED IN THIS DRAWING IS THE SOLE PROPERTY OF <INSERT COMPANY NAME HERE>. ANY REPRODUCTION IN PART OR AS A WHOLE WITHOUT THE WRITTEN PERMISSION OF <INSERT COMPANY NAME HERE> IS PROHIBITED.

		UNLESS OTHERWISE SPECIFIED:	NAME	DATE
		DIMENSIONS ARE IN INCHES TOLERANCES: FRACTIONAL ± ANGULAR: MACH ± BEND ± TWO PLACE DECIMAL ± THREE PLACE DECIMAL ±	DRAWN	
		INTERPRET GEOMETRIC TOLERANCING PER:	CHECKED	
		MATERIAL	ENG APPR.	
		FINISH	MFG APPR.	
NEXT ASSY	USED ON		Q.A.	
APPLICATION	DO NOT SCALE DRAWING		COMMENTS:	

7/8" ROUND ALUMINUM TUBE

TITLE:

ACP-LA-S-SR-6-26-40W-MN-WF-DIM-27K

SIZE DWG. NO. REV

A

SCALE: 1:3 WEIGHT: SHEET 9 OF 11

ITEM NO.	PART NUMBER	DESCRIPTION	QTY.
1	ACP-LA-S-SR-6-26-40W-MN-WF-DIM-27K-SPUN TOP CAP	SPUN ALUMINUM 0.080"	1

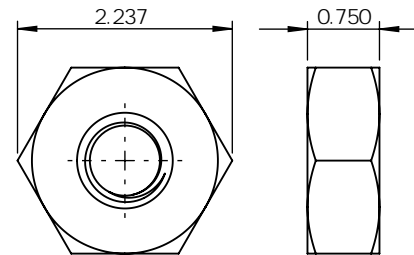
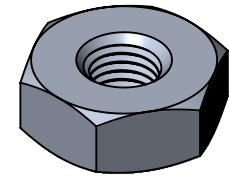
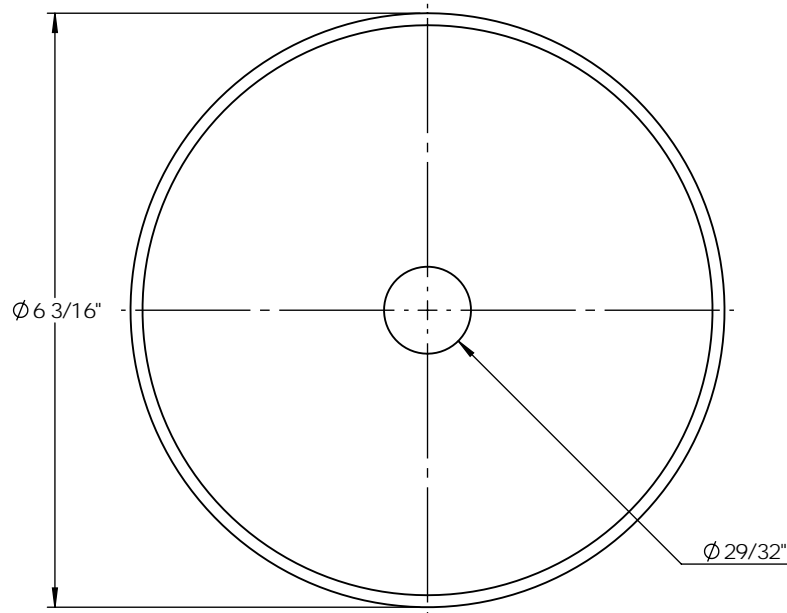
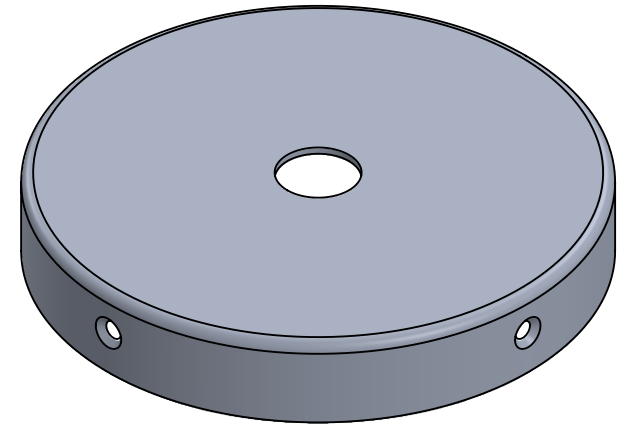
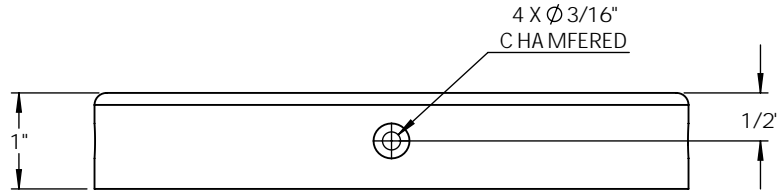

<p>PROPRIETARY AND CONFIDENTIAL THE INFORMATION CONTAINED IN THIS DRAWING IS THE SOLE PROPERTY OF <INSERT COMPANY NAME HERE>. ANY REPRODUCTION IN PART OR AS A WHOLE WITHOUT THE WRITTEN PERMISSION OF <INSERT COMPANY NAME HERE> IS PROHIBITED.</p>			UNLESS OTHERWISE SPECIFIED:		NAME	DATE	SPUN ALUMINUM 0.080"		
			DIMENSIONS ARE IN INCHES TOLERANCES: FRACTIONAL ± ANGULAR: MACH ± BEND ± TWO PLACE DECIMAL ± THREE PLACE DECIMAL ±		DRAWN		TITLE:		
			INTERPRET GEOMETRIC TOLERANCING PER:		CHECKED		ACP-LA-S-SR-6-26-40W-MN-WF-DIM-27K		
			MATERIAL		ENG APPR.		SIZE DWG. NO. REV		
			FINISH		MFG APPR.		SCALE: 1:2 WEIGHT: SHEET 10 OF 11		
	NEXT ASSY	USED ON		Q.A.					
	APPLICATION		DO NOT SCALE DRAWING	COMMENTS:					

5

4

3

2

1

ITEM NO.	PART NUMBER	DESCRIPTION	QTY.
1	ACP-LA-S-SR-6-26-40W-MN-WF-DIM-27K-SPUN BOTTOM CAP	SPUN ALUMINUM 0.080"	1

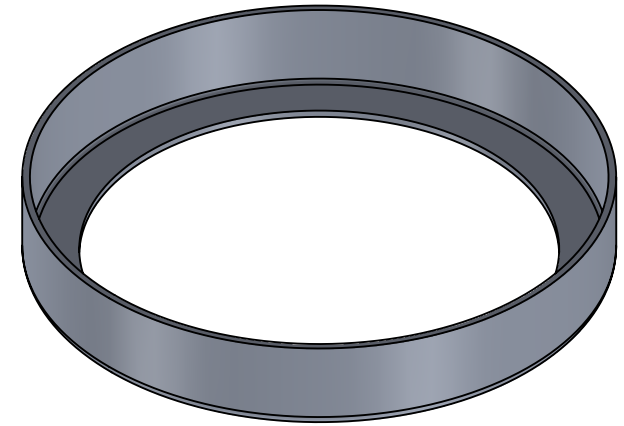
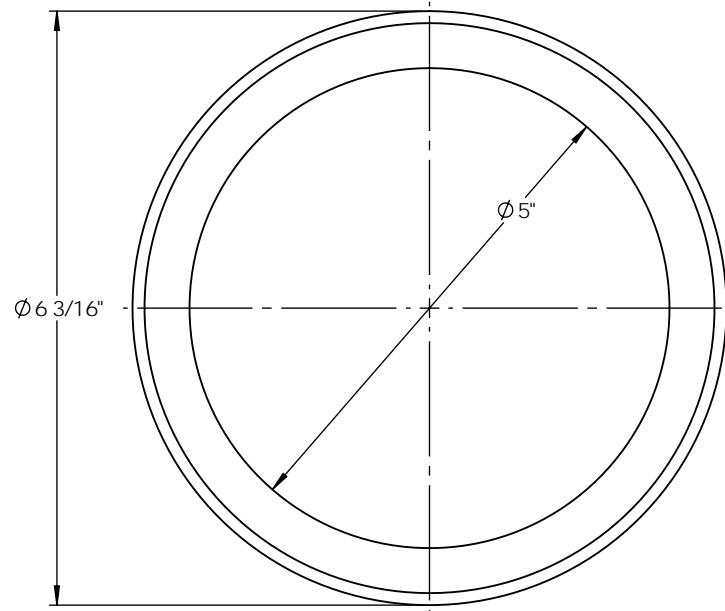
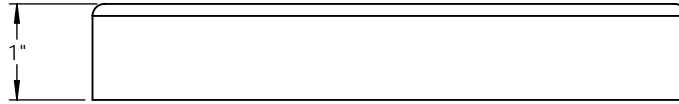

<p>PROPRIETARY AND CONFIDENTIAL THE INFORMATION CONTAINED IN THIS DRAWING IS THE SOLE PROPERTY OF <INSERT COMPANY NAME HERE>. ANY REPRODUCTION IN PART OR AS A WHOLE WITHOUT THE WRITTEN PERMISSION OF <INSERT COMPANY NAME HERE> IS PROHIBITED.</p>			UNLESS OTHERWISE SPECIFIED:		NAME	DATE	SPUN ALUMINUM 0.080"	
			DIMENSIONS ARE IN INCHES TOLERANCES: FRACTIONAL ± ANGULAR: MACH ± BEND ± TWO PLACE DECIMAL ± THREE PLACE DECIMAL ±	DRAWN			TITLE:	
			INTERPRET GEOMETRIC TOLERANCING PER:	CHECKED			ACP-LA-S-SR-6-26-40W-MN-WF-DIM-27K	
			MATERIAL	ENG APPR.			REV	
			FINISH	MFG APPR.			SCALE: 1:2 WEIGHT: SHEET 11 OF 11	
	NEXT ASSY	USED ON	DO NOT SCALE DRAWING	Q.A.	COMMENTS:			
	APPLICATION						SIZE	DWG. NO.
							A	

5

4

3

2

1