

ALL BEND RADIUS .030"

APPLICATION

UNLESS OTHERWISE SPECIFIED:  
 DIMENSIONS ARE IN INCHES  
 TOLERANCES:  
 FRACTIONAL  $\pm .003$   
 ANGULAR: MACH  $\pm .01$  BEND  $\pm$   
 TWO PLACE DECIMAL  $\pm$   
 THREE PLACE DECIMAL  $\pm .001$   
 INTERPRET GEOMETRIC  
 TOLERANCING PER:  
 MATERIAL  
 FINISH

DO NOT SCALE DRAWING

| NAME      | DATE |
|-----------|------|
| DRAWN     |      |
| CHECKED   |      |
| ENG APPR. |      |
| MFG APPR. |      |
| Q.A.      |      |
| COMMENTS: |      |

|                                     |          |               |
|-------------------------------------|----------|---------------|
| TITLE:                              |          |               |
| ACP-LA-Q-SR-6-26-160W-MN-WF-DIM-27K |          |               |
| SIZE                                | DWG. NO. | REV           |
| <b>A</b>                            |          |               |
| SCALE: 1:16                         | WEIGHT:  | SHEET 1 OF 15 |

5

4

3

2

1

| ITEM NO. | PART NUMBER  | DESCRIPTION                 | QTY. | CUT |
|----------|--|-----------------------------|------|-----|
| 1        | 8" SWIVEL CANOPY   | SPUN ALUMINUM 0.080"        | 1    |     |
| 2        | ACP-LA-Q-SR-6-26-160W-MN-WF-DIM-27K-SPUN TOP CAP               | SPUN ALUMINUM 0.080"        | 4    |     |
| 3        | ACP-LA-Q-SR-6-26-160W-MN-WF-DIM-27K-SPUN BOTTOM CAP            | SPUN ALUMINUM 0.080"        | 4    |     |
| 4        | SWIVEL BRACKET   | SWIVEL BRACKET              | 1    |     |
| 5        | SWIVEL   | SWIVEL                      | 1    |     |
| 6        | .375 BRASS BALL  | 3/8" BRASS BALL             | 2    |     |
| 7        | ACP-LA-Q-SR-6-26-160W-MN-WF-DIM-27K-2" CYLINDER POST           | 2" ALUMINUM TUBE POST       | 1    |     |
| 8        | ACP-LA-Q-SR-6-26-160W-MN-WF-DIM-27K-0.875" STEM TUBE           | 7/8" ROUND ALUMINUM TUBE    | 1    |     |
| 9        | ACP-LA-Q-SR-6-26-160W-MN-WF-DIM-27K-0.875" STEM TUBE           | 7/8" ROUND ALUMINUM TUBE    | 4    |     |
| 10       | ACP-LA-Q-SR-6-26-160W-MN-WF-DIM-27K-SQUARE LED TUBE            | 1" SQUARE ALUMINUM TUBE     | 4    |     |
| 11       | ACP-LA-Q-SR-6-26-160W-MN-WF-DIM-27K-SQUARE ARM TUBE            | 1-1/2" SQUARE ALUMINUM TUBE | 4    |     |
| 12       | ACP-LA-Q-SR-6-26-160W-MN-WF-DIM-27K-2" CYLINDER POST           | 2" ALUMINUM TUBE POST       | 4    |     |
| 13       | ACP-LA-Q-SR-6-26-160W-MN-WF-DIM-27K-REFLECTOR BRACKET          | ALUMINUM 0.0635"            | 4    |     |
| 14       | ACP-LA-Q-SR-6-26-160W-MN-WF-DIM-27K-REFLECTOR PLATE            | ALUMINUM 0.125" PLATE       | 4    |     |
| 15       | ACP-LA-Q-SR-6-26-160W-MN-WF-DIM-27K-2" CYLINDER PLATE SOLID    | ALUMINUM 0.250" PLATE       | 5    |     |
| 16       | ACP-LA-T-SR-6-26-120W-MN-WF-DIM-27K-2" CYLINDER PLATE THREADED | ALUMINUM 0.500" PLATE       | 5    |     |
| 17       | ACP-LA-Q-SR-6-26-160W-MN-WF-DIM-27K-ACRYLIC TUBE               | ACRYLIC                     | 4    |     |
| 18       | ACP-LA-Q-SR-6-26-160W-MN-WF-DIM-27K-ACRYLIC PLATE              | ACRYLIC                     | 4    |     |
| 19       | 8-32-0.5 SS Hex Drive Flat Head                                | 8-32 FLAT HEAD SCREW        | 16   |     |
| 20       | AILED PN105B-11-2.5-SS   | LED                         | 32   |     |
| 21       | AC25CD70QA T2Q LED DRIVER                                      | DRIVER                      | 8    |     |
| 22       | 92949A 194   | 8-32 HEAD SCREW             | 16   |     |
| 23       | 90670A 270   | ALUMINUM HEX NUT            | 4    |     |
| 24       | 93225A 571   | THREADED STUD               | 2    |     |

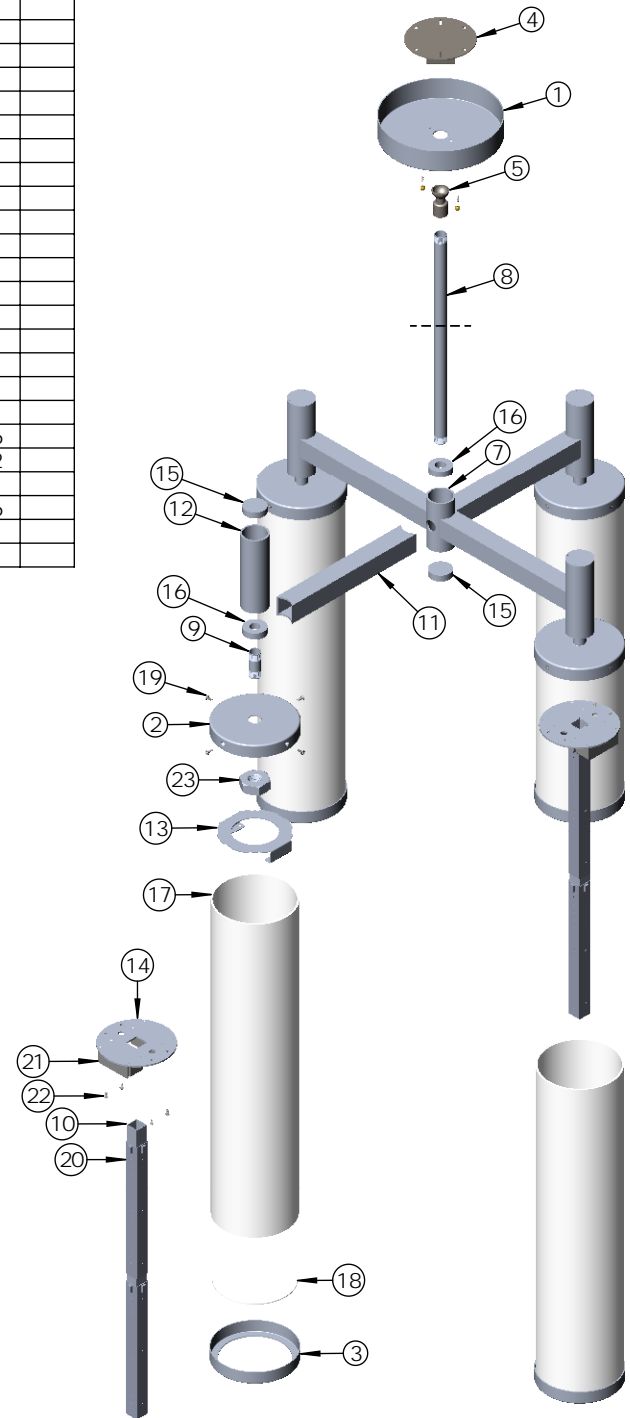

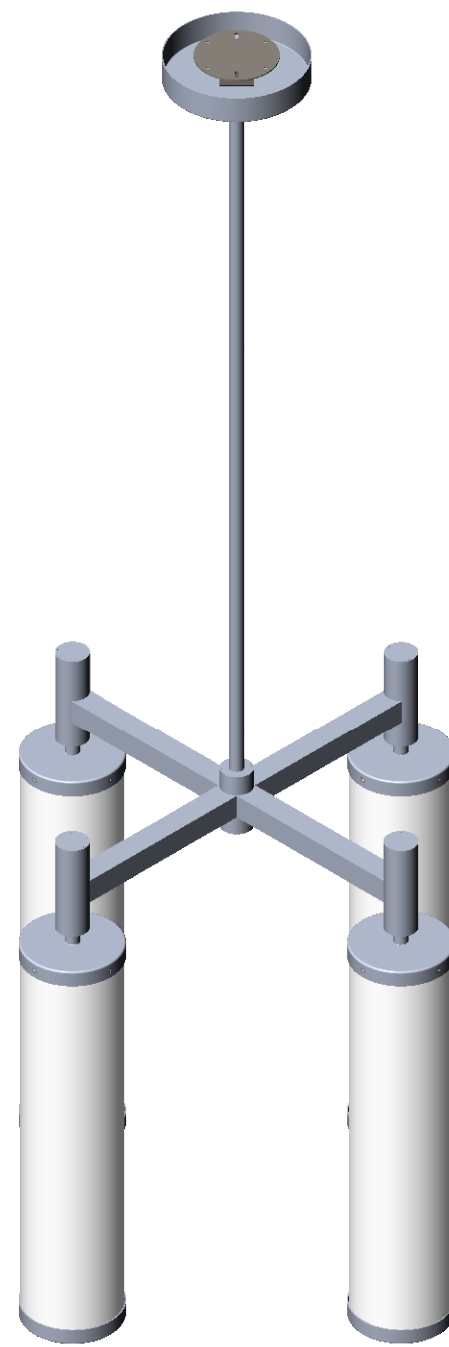
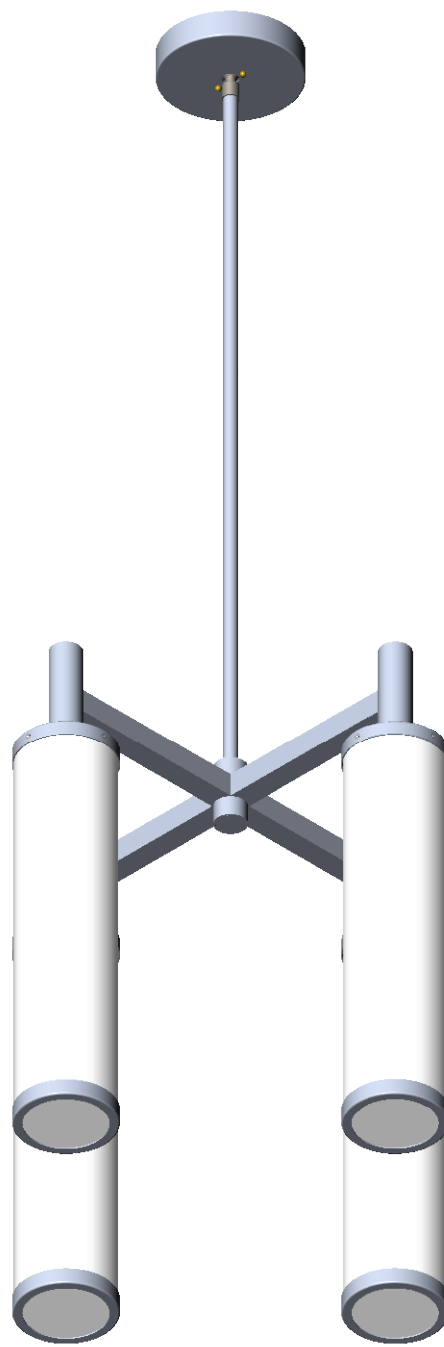
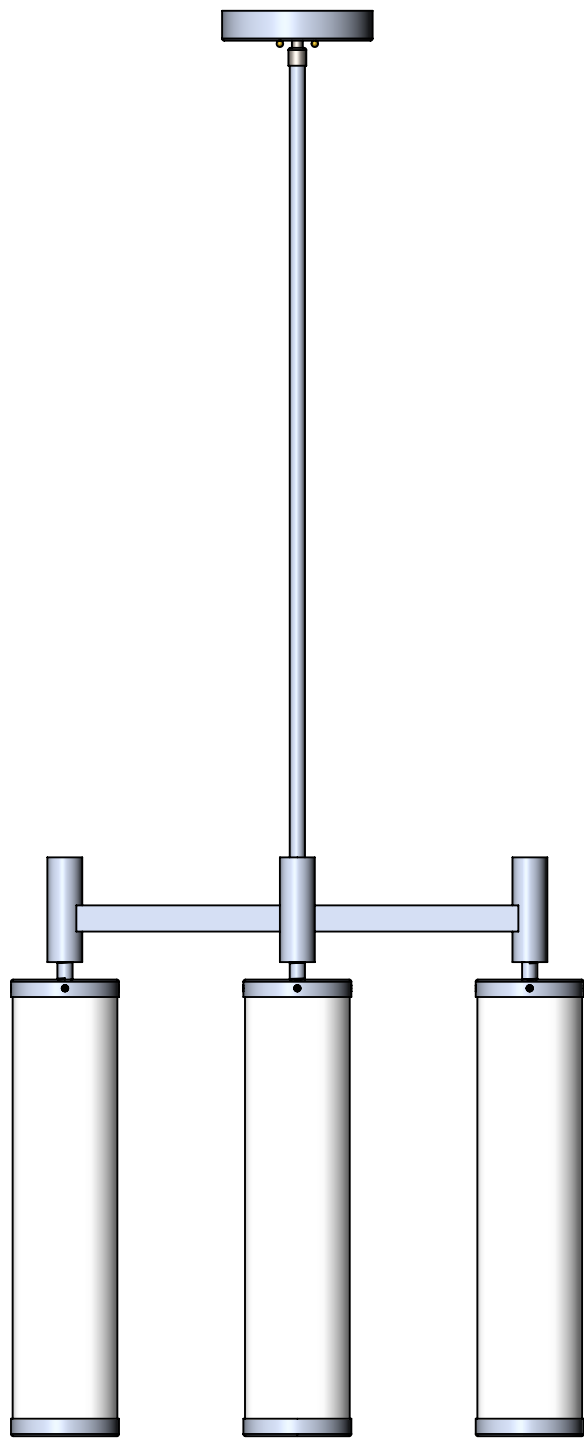

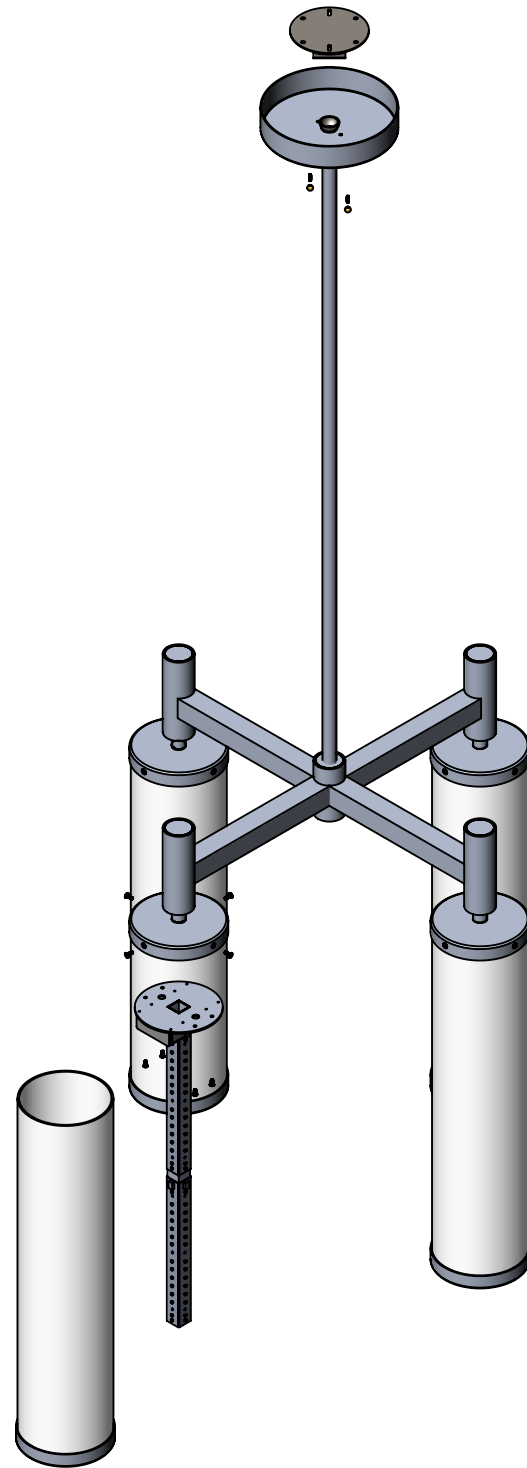
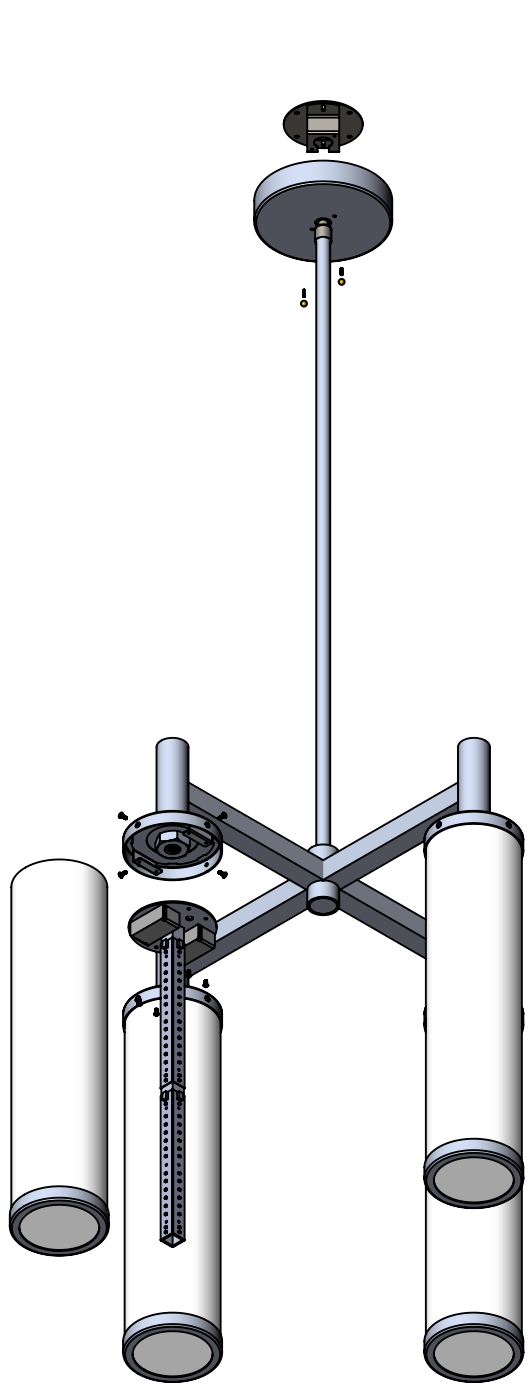

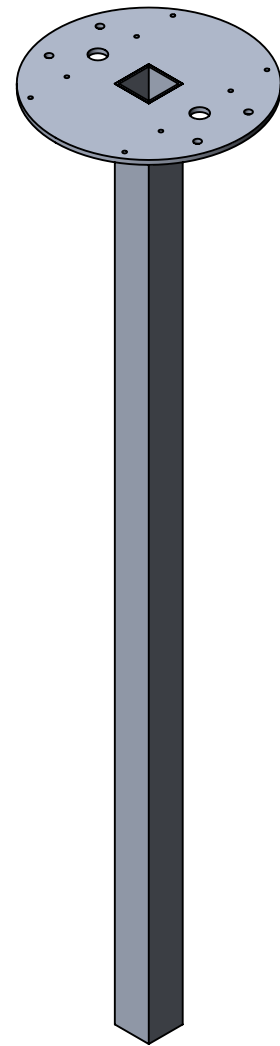
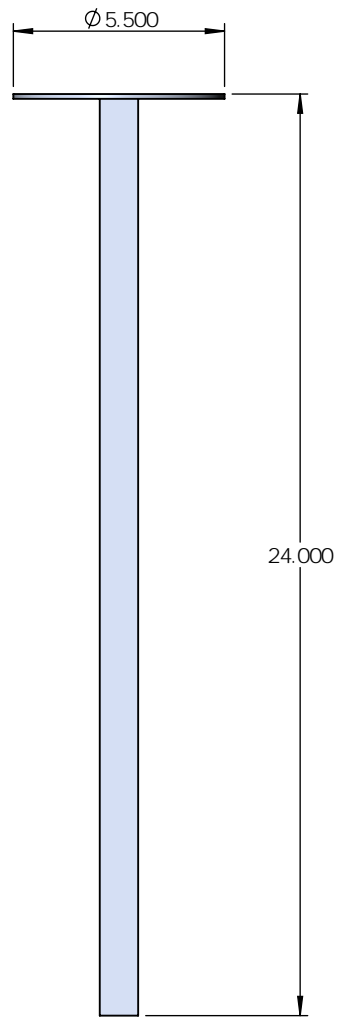
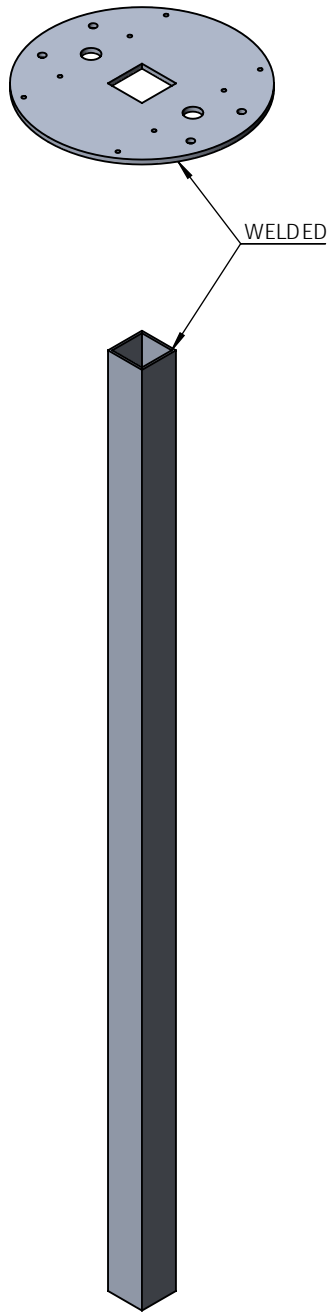

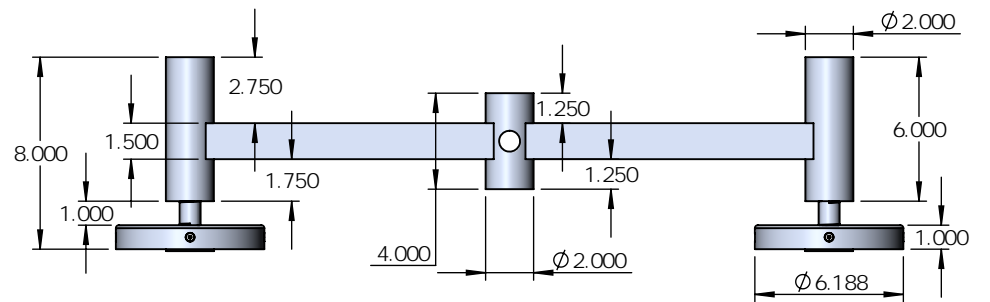
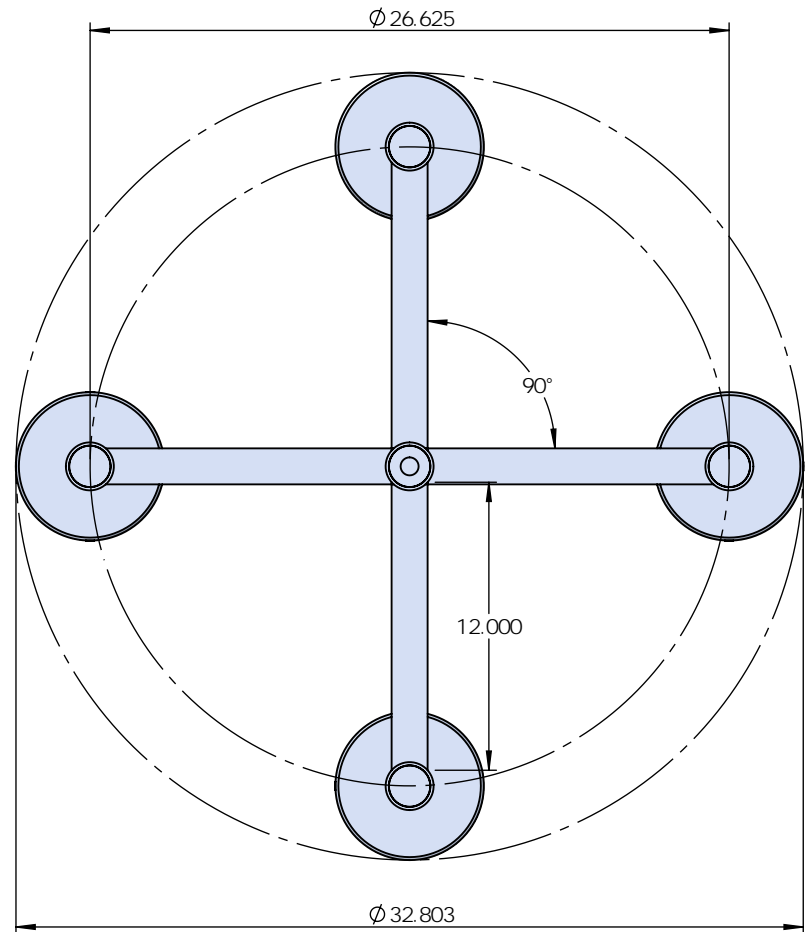
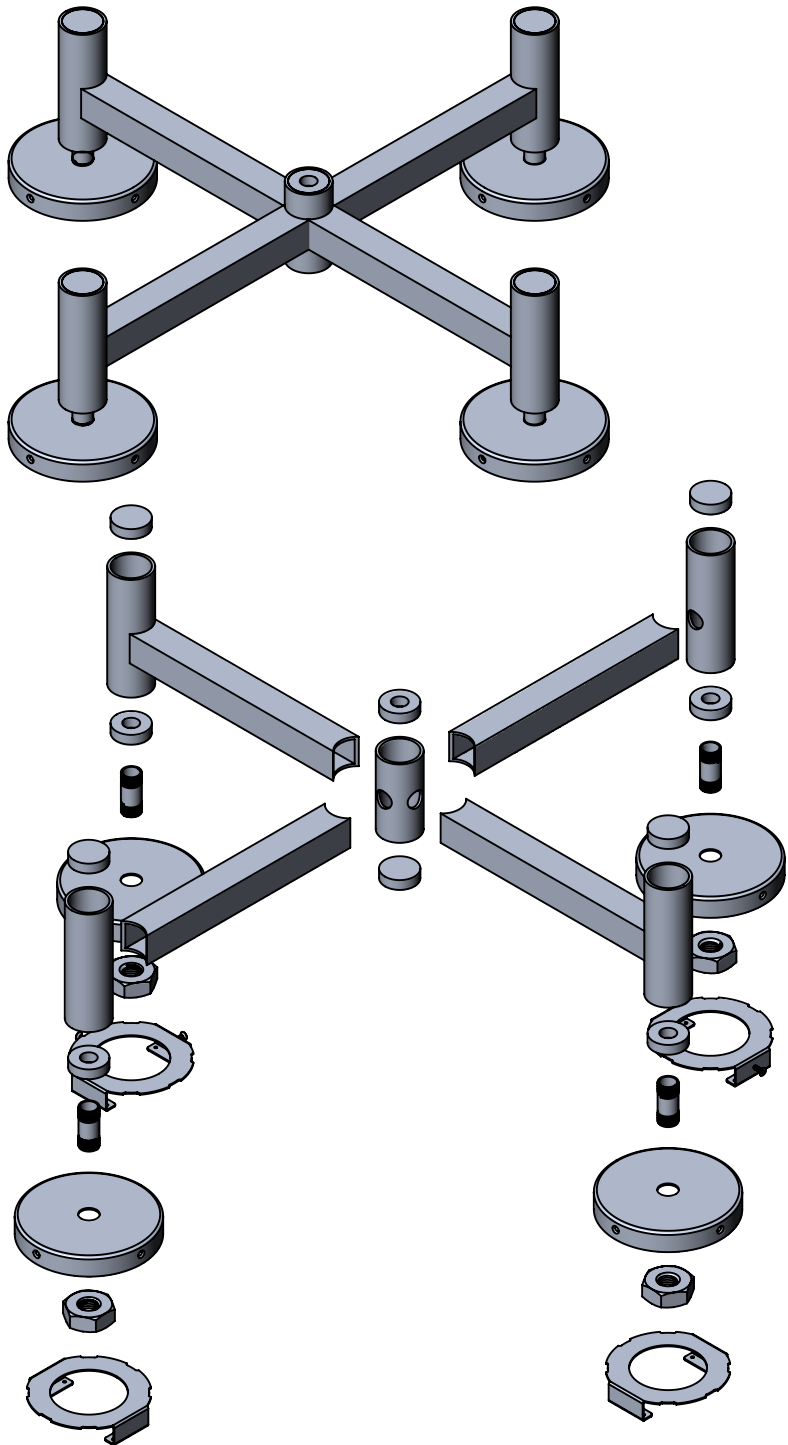

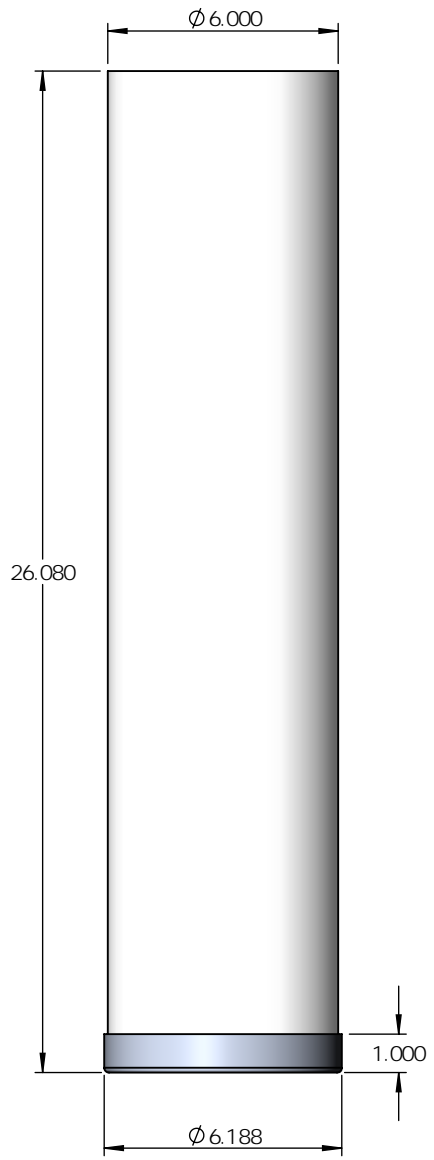

G LUED

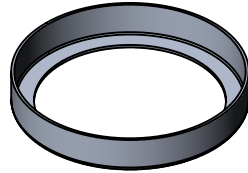
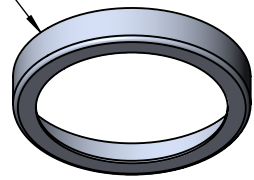
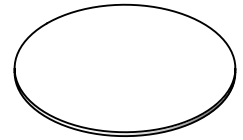
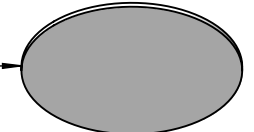
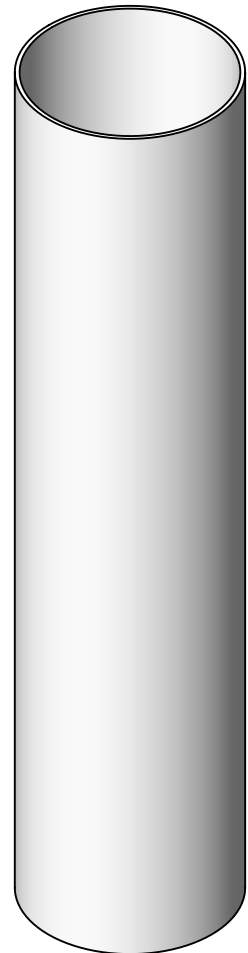
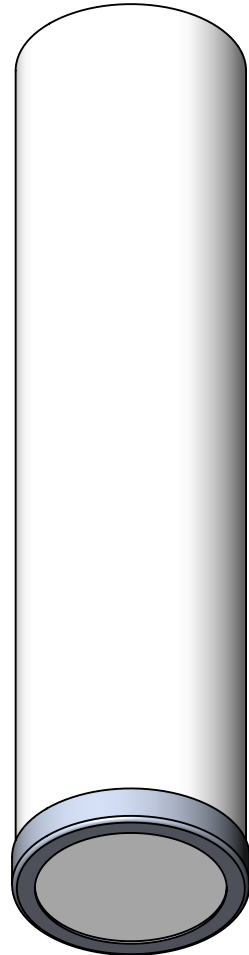
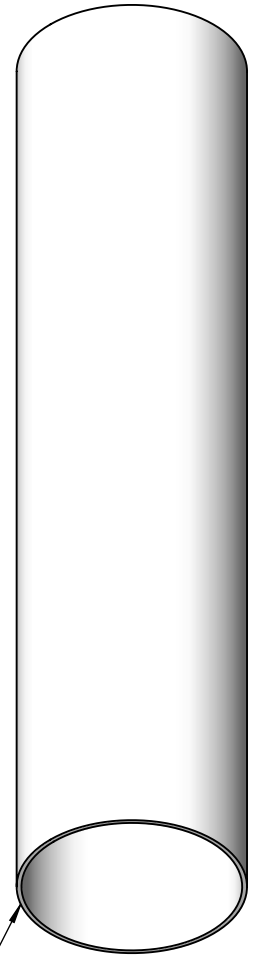

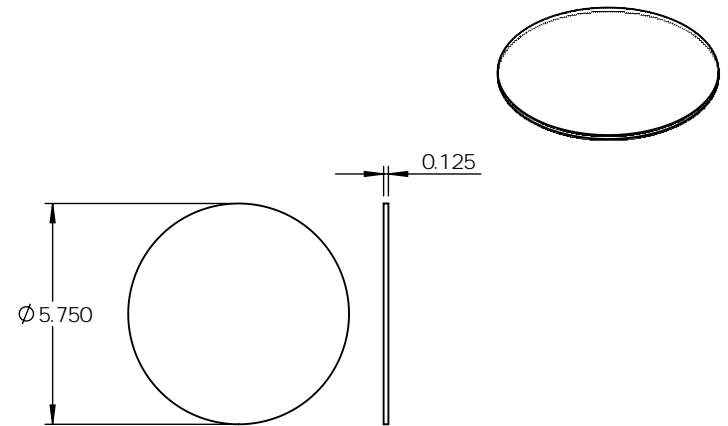
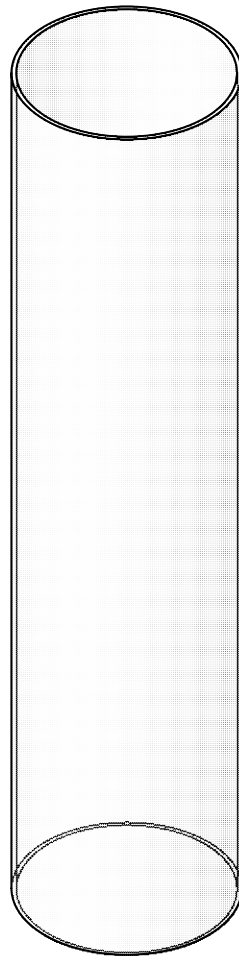
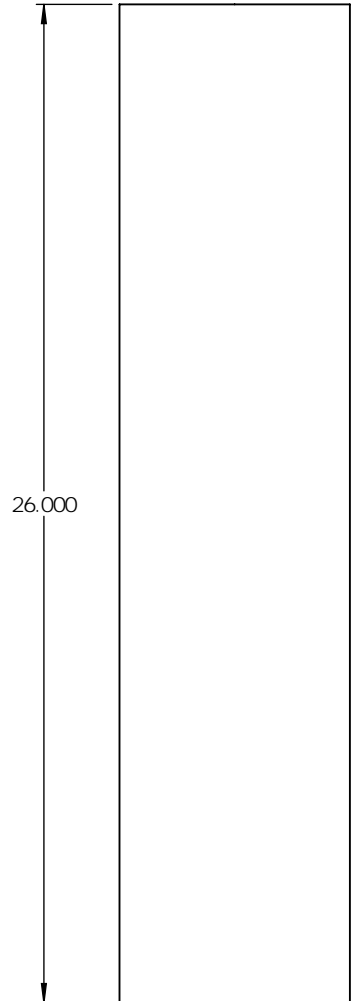
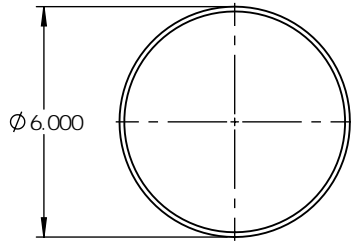

**PROPRIETARY AND CONFIDENTIAL**  
 THE INFORMATION CONTAINED IN THIS DRAWING IS THE SOLE PROPERTY OF <INSERT COMPANY NAME HERE>. ANY REPRODUCTION IN PART OR AS A WHOLE WITHOUT THE WRITTEN PERMISSION OF <INSERT COMPANY NAME HERE> IS PROHIBITED.

|             |         |
|-------------|---------|
|             |         |
| NEXT ASSY   | USED ON |
| APPLICATION |         |

|   |
|---|
| UNLESS OTHERWISE SPECIFIED:   |
| DIMENSIONS ARE IN INCHES<br>TOLERANCES:<br>FRACTIONAL ±<br>ANGULAR: MACH ± BEND ±<br>TWO PLACE DECIMAL ±<br>THREE PLACE DECIMAL ± |
| INTERPRET GEOMETRIC TOLERANCING PER:  |
| MATERIAL  |
| FINISH  |
| DO NOT SCALE DRAWING  |

|           |      |      |
|-----------|------|------|
|           | NAME | DATE |
| DRAWN     |      |      |
| CHECKED   |      |      |
| ENG APPR. |      |      |
| MFG APPR. |      |      |
| Q.A.      |      |      |
| COMMENTS: |      |      |

|  |          |               |
|--|----------|---------------|
| ACRYLIC                                |          |               |
| TITLE:                                 |          |               |
| AC P-LA -Q -SR-6-26-160W-MN-WF-DIM-27K |          |               |
| SIZE                                   | DWG. NO. | REV           |
| <b>A</b>                               |          |               |
| SCALE: 1:5                             | WEIGHT:  | SHEET 8 OF 15 |

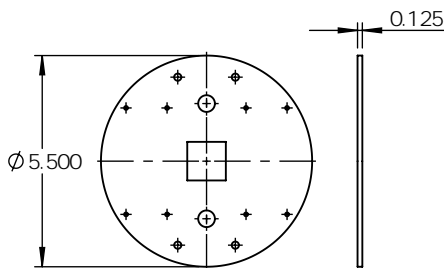
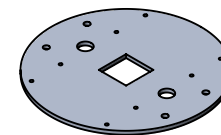
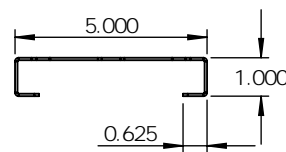
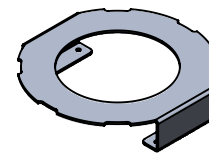
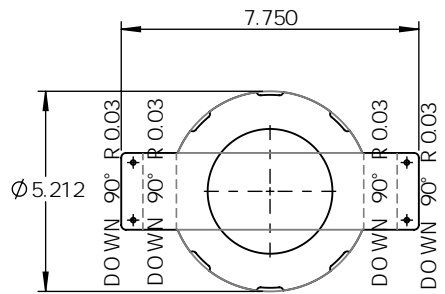
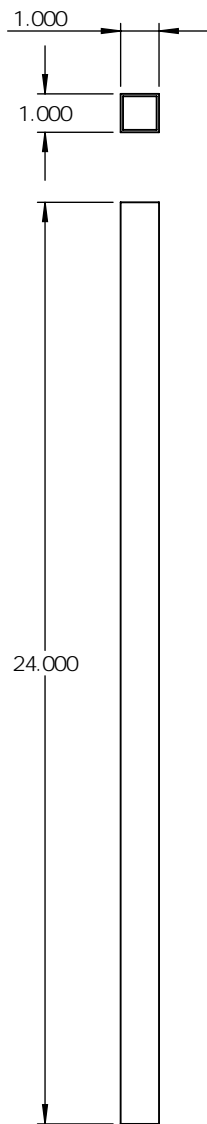

**PROPRIETARY AND CONFIDENTIAL**  
 THE INFORMATION CONTAINED IN THIS DRAWING IS THE SOLE PROPERTY OF <INSERT COMPANY NAME HERE>. ANY REPRODUCTION IN PART OR AS A WHOLE WITHOUT THE WRITTEN PERMISSION OF <INSERT COMPANY NAME HERE> IS PROHIBITED.

|             |                      |   |           |      |
|-------------|----------------------|---|-----------|------|
|             |                      | UNLESS OTHERWISE SPECIFIED:   | NAME      | DATE |
|             |                      | DIMENSIONS ARE IN INCHES<br>TOLERANCES:<br>FRACTIONAL ±<br>ANGULAR: MACH ± BEND ±<br>TWO PLACE DECIMAL ±<br>THREE PLACE DECIMAL ± | DRAWN     |      |
|             |                      | INTERPRET GEOMETRIC TOLERANCING PER:  | CHECKED   |      |
|             |                      | MATERIAL  | ENG APPR. |      |
|             |                      | FINISH  | MFG APPR. |      |
| NEXT ASSY   | USED ON              |   | Q.A.      |      |
| APPLICATION | DO NOT SCALE DRAWING |   | COMMENTS: |      |

|   |          |               |
|---|----------|---------------|
| A LUMINUM 0.0635"                       |          |               |
| TITLE:                                  |          |               |
| A C P-LA -Q -SR-6-26-160W-MN-WF-DIM-27K |          |               |
| SIZE                                    | DWG. NO. | REV           |
| <b>A</b>                                |          |               |
| SCALE: 1:5                              | WEIGHT:  | SHEET 9 OF 15 |

| ITEM NO. | PART NUMBER      | DESCRIPTION          | QTY. |
|----------|------------------|----------------------|------|
| 1        | 8" SWIVEL CANOPY | SPUN ALUMINUM 0.080" | 1    |

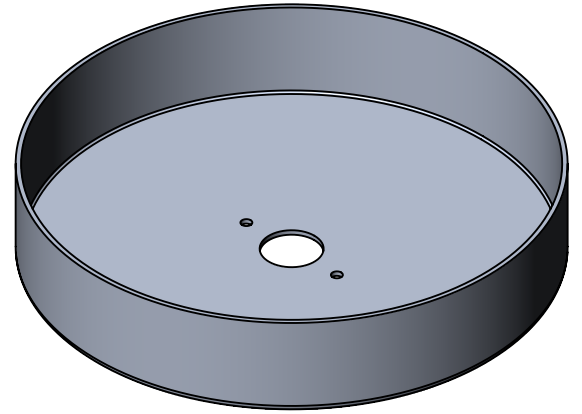
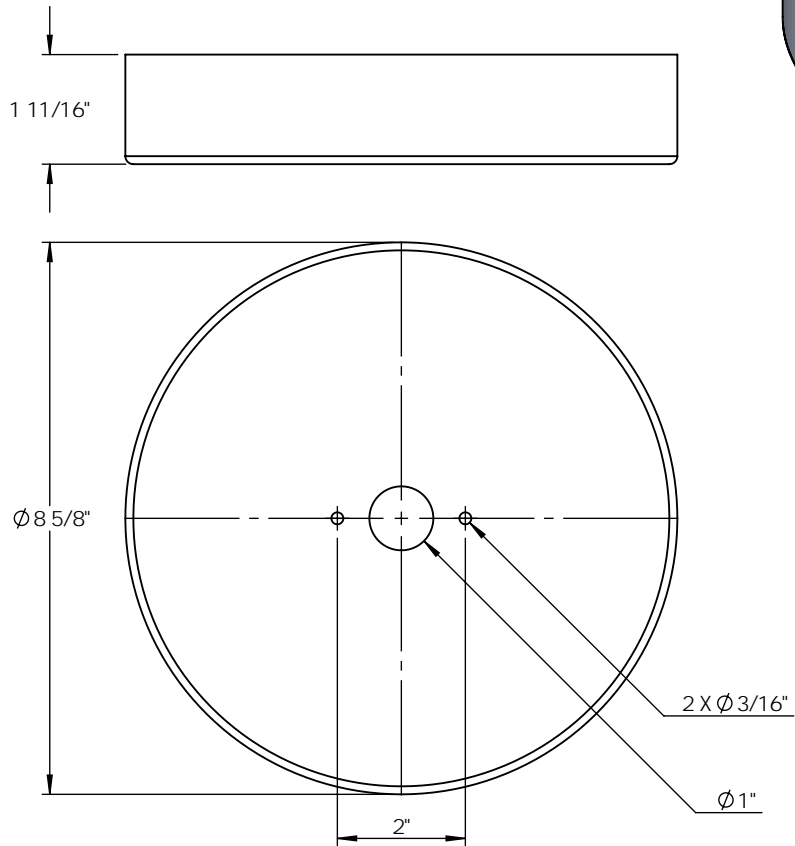
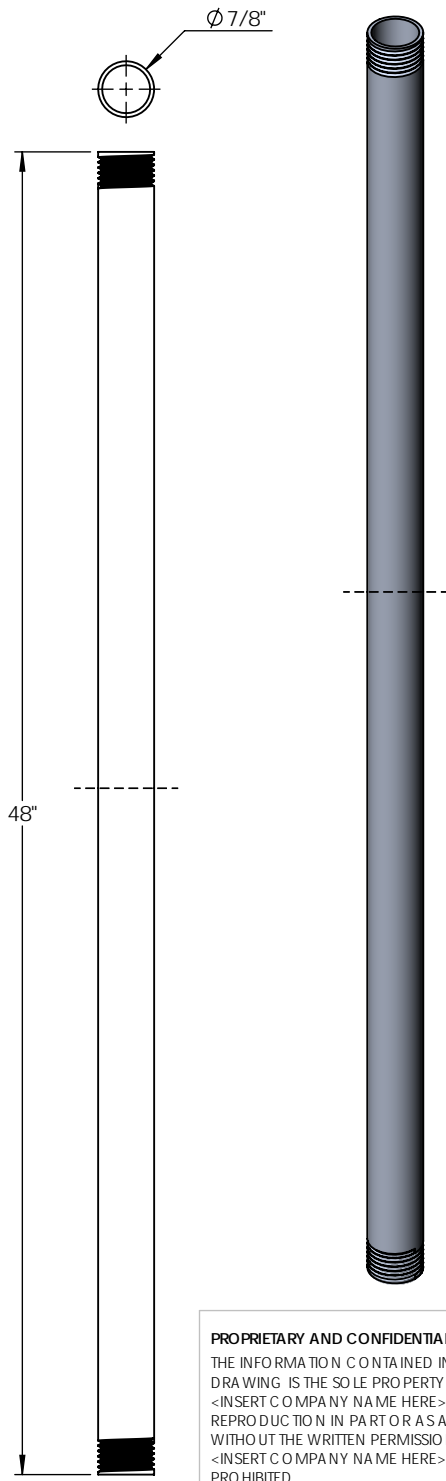

**PROPRIETARY AND CONFIDENTIAL**  
 THE INFORMATION CONTAINED IN THIS DRAWING IS THE SOLE PROPERTY OF <INSERT COMPANY NAME HERE>. ANY REPRODUCTION IN PART OR AS A WHOLE WITHOUT THE WRITTEN PERMISSION OF <INSERT COMPANY NAME HERE> IS PROHIBITED.

|             |                      |                                      |           |      |
|-------------|----------------------|--------------------------------------|-----------|------|
|             |                      | UNLESS OTHERWISE SPECIFIED:          | NAME      | DATE |
|             |                      | DIMENSIONS ARE IN INCHES             | DRAWN     |      |
|             |                      | TOLERANCES:                          | CHECKED   |      |
|             |                      | FRACTIONAL ±                         | ENG APPR. |      |
|             |                      | ANGULAR: MACH ± BEND ±               | MFG APPR. |      |
|             |                      | TWO PLACE DECIMAL ±                  | Q.A.      |      |
|             |                      | THREE PLACE DECIMAL ±                | COMMENTS: |      |
|             |                      | INTERPRET GEOMETRIC TOLERANCING PER: |           |      |
|             |                      | MATERIAL                             |           |      |
|             |                      | FINISH                               |           |      |
| NEXT ASSY   | USED ON              |                                      |           |      |
| APPLICATION | DO NOT SCALE DRAWING |                                      |           |      |

7/8" ROUND ALUMINUM TUBE

TITLE:

ACP-LA-Q-SR-6-26-160W-MN-WF-DIM-27K

SIZE DWG. NO. REV

**A**

SCALE: 1:3 WEIGHT: SHEET 10 OF 15

| ITEM NO. | PART NUMBER                                      | DESCRIPTION          | QTY. |
|----------|--|----------------------|------|
| 1        | ACP-LA-Q-SR-6-26-16OW-MN-WF-DIM-27K-SPUN TOP CAP | SPUN ALUMINUM 0.080" | 1    |

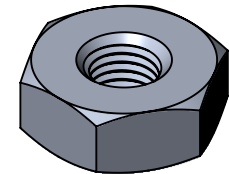
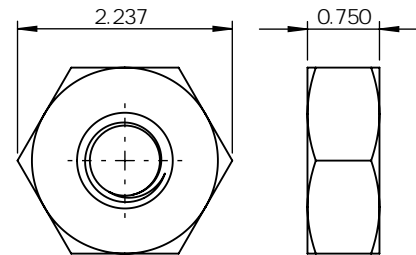
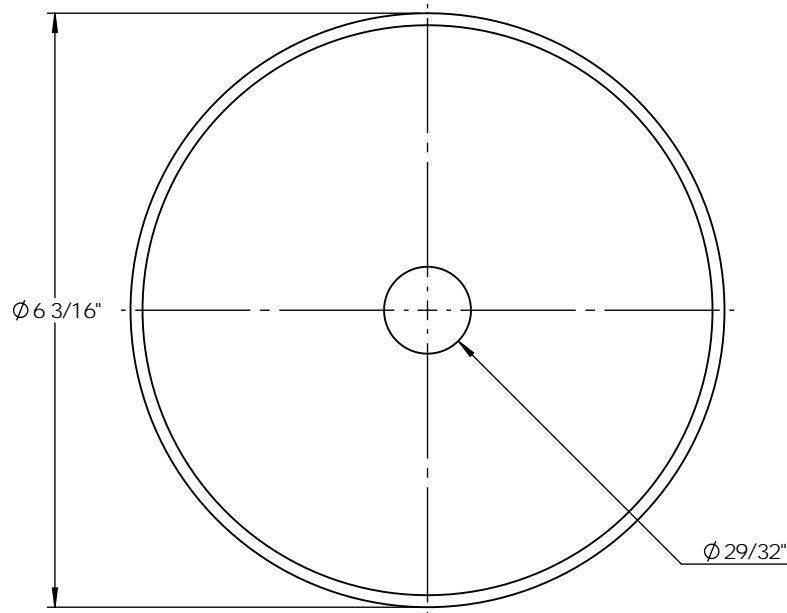
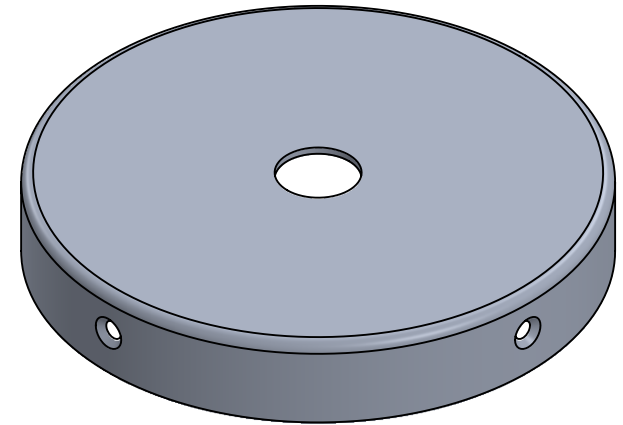
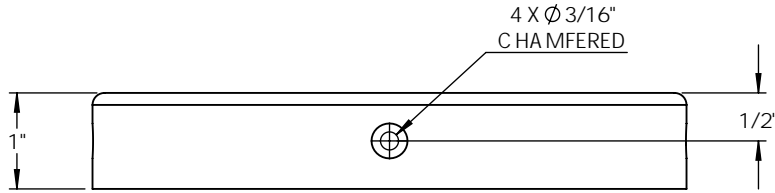

|   |             |         |   |           |           |      |                                     |         |                |     |
|---|-------------|---------|---|-----------|-----------|------|-------------------------------------|---------|----------------|-----|
| <p><b>PROPRIETARY AND CONFIDENTIAL</b><br/>THE INFORMATION CONTAINED IN THIS DRAWING IS THE SOLE PROPERTY OF &lt;INSERT COMPANY NAME HERE&gt;. ANY REPRODUCTION IN PART OR AS A WHOLE WITHOUT THE WRITTEN PERMISSION OF &lt;INSERT COMPANY NAME HERE&gt; IS PROHIBITED.</p> |             |         | UNLESS OTHERWISE SPECIFIED:   |           | NAME      | DATE | SPUN ALUMINUM 0.080"                |         |                |     |
|   |             |         | DIMENSIONS ARE IN INCHES<br>TOLERANCES:<br>FRACTIONAL ±<br>ANGULAR: MACH ± BEND ±<br>TWO PLACE DECIMAL ±<br>THREE PLACE DECIMAL ± |           | DRAWN     |      | TITLE:                              |         |                |     |
|   |             |         | INTERPRET GEOMETRIC<br>TOLERANCING PER:   |           | CHECKED   |      | ACP-LA-Q-SR-6-26-16OW-MN-WF-DIM-27K |         |                |     |
|   |             |         | MATERIAL  |           | ENG APPR. |      |                                     | SIZE    | DWG. NO.       | REV |
|   |             |         | FINISH  |           | MFG APPR. |      | <b>A</b>                            |         |                |     |
|   | NEXT ASSY   | USED ON |   | Q.A.      |           |      | SCALE: 1:2                          | WEIGHT: | SHEET 11 OF 15 |     |
|   | APPLICATION |         | DO NOT SCALE DRAWING  | COMMENTS: |           |      |                                     |         |                |     |

| ITEM NO. | PART NUMBER   | DESCRIPTION          | QTY. |
|----------|---|----------------------|------|
| 1        | ACP-LA-Q-SR-6-26-160W-MN-WF-DIM-27K-SPUN BOTTOM CAP | SPUN ALUMINUM 0.080" | 1    |

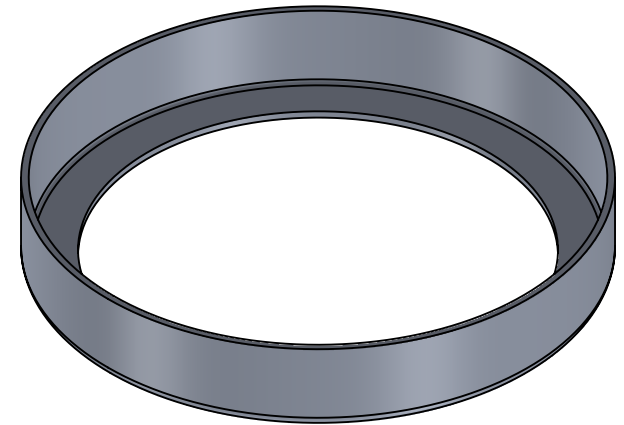
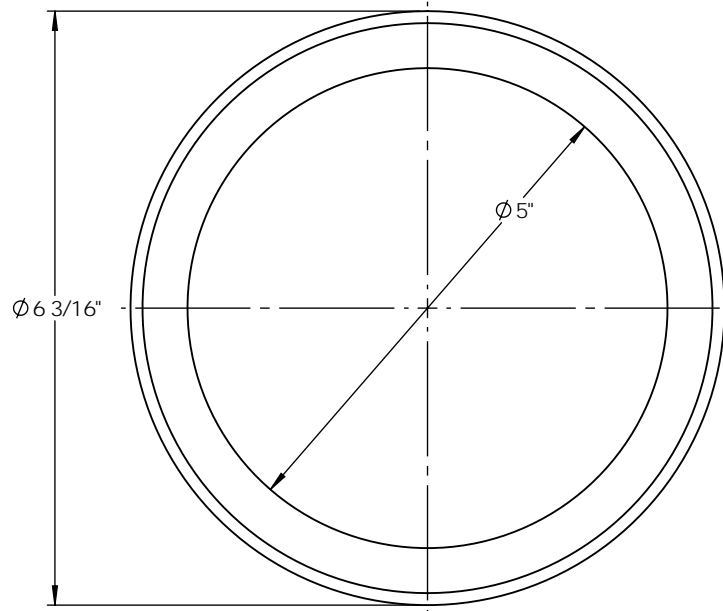
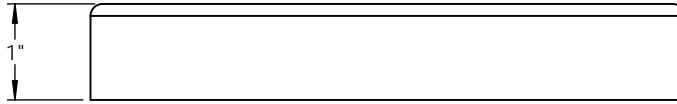

|   |             |         |   |           |      |            |                                     |                |     |
|---|-------------|---------|---|-----------|------|------------|-------------------------------------|----------------|-----|
| <p><b>PROPRIETARY AND CONFIDENTIAL</b><br/>THE INFORMATION CONTAINED IN THIS DRAWING IS THE SOLE PROPERTY OF &lt;INSERT COMPANY NAME HERE&gt;. ANY REPRODUCTION IN PART OR AS A WHOLE WITHOUT THE WRITTEN PERMISSION OF &lt;INSERT COMPANY NAME HERE&gt; IS PROHIBITED.</p> |             |         | UNLESS OTHERWISE SPECIFIED:   |           | NAME | DATE       | SPUN ALUMINUM 0.080"                |                |     |
|   |             |         | DIMENSIONS ARE IN INCHES<br>TOLERANCES:<br>FRACTIONAL ±<br>ANGULAR: MACH ± BEND ±<br>TWO PLACE DECIMAL ±<br>THREE PLACE DECIMAL ± | DRAWN     |      |            | TITLE:                              |                |     |
|   |             |         | INTERPRET GEOMETRIC<br>TOLERANCING PER:   | CHECKED   |      |            | ACP-LA-Q-SR-6-26-160W-MN-WF-DIM-27K |                |     |
|   |             |         | MATERIAL  | ENG APPR. |      |            | SIZE                                | DWG. NO.       | REV |
|   |             |         | FINISH  | MFG APPR. |      |            | <b>A</b>                            |                |     |
|   | NEXT ASSY   | USED ON | COMMENTS:   | Q.A.      |      | SCALE: 1:2 | WEIGHT:                             | SHEET 12 OF 15 |     |
|   | APPLICATION |         | DO NOT SCALE DRAWING  |           |      |            |                                     |                |     |

5

4

3

2

1

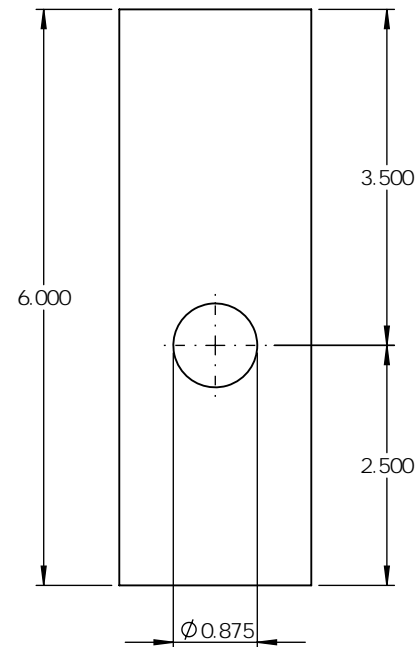
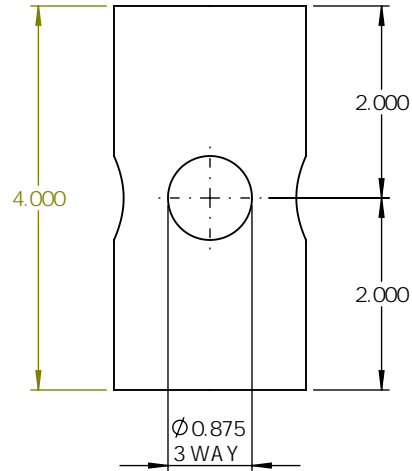
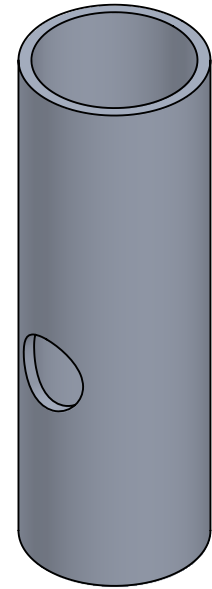
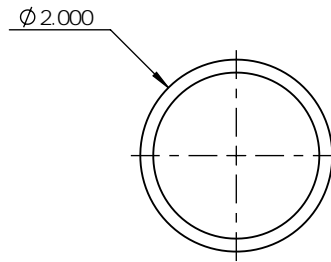
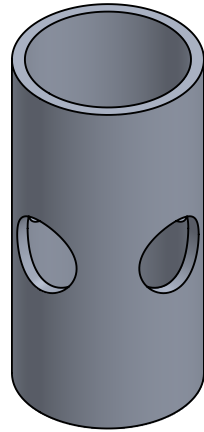
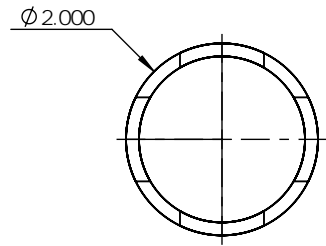

**PROPRIETARY AND CONFIDENTIAL**  
 THE INFORMATION CONTAINED IN THIS DRAWING IS THE SOLE PROPERTY OF <INSERT COMPANY NAME HERE>. ANY REPRODUCTION IN PART OR AS A WHOLE WITHOUT THE WRITTEN PERMISSION OF <INSERT COMPANY NAME HERE> IS PROHIBITED.

|             |                      |   |           |      |
|-------------|----------------------|---|-----------|------|
|             |                      | UNLESS OTHERWISE SPECIFIED:   | NAME      | DATE |
|             |                      | DIMENSIONS ARE IN INCHES<br>TOLERANCES:<br>FRACTIONAL ±<br>ANGULAR: MACH ± BEND ±<br>TWO PLACE DECIMAL ±<br>THREE PLACE DECIMAL ± | DRAWN     |      |
|             |                      | INTERPRET GEOMETRIC<br>TOLERANCING PER:   | CHECKED   |      |
|             |                      | MATERIAL  | ENG APPR. |      |
|             |                      | FINISH  | MFG APPR. |      |
| NEXT ASSY   | USED ON              |   | Q.A.      |      |
| APPLICATION | DO NOT SCALE DRAWING |   | COMMENTS: |      |

2" A LUMINUM TUBE POST

TITLE:  
 ACP-LA-Q-SR-6-26-160W-MN-WF-DIM-27K

SIZE DWG. NO. REV  
**A**

SCALE: 1:2 WEIGHT: SHEET 13 OF 15

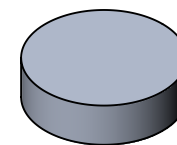
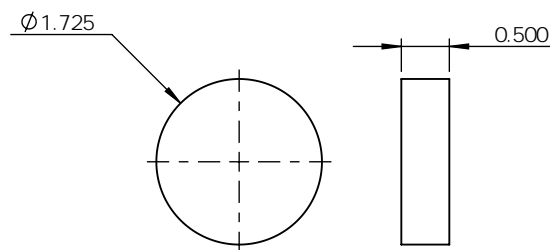
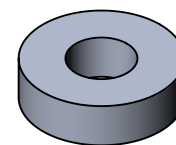
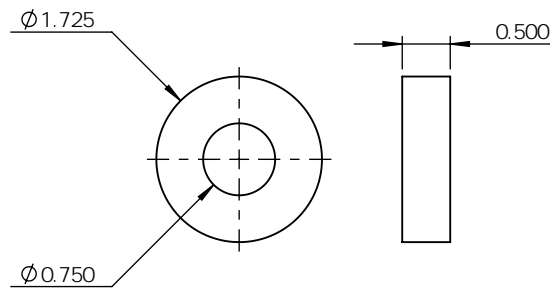
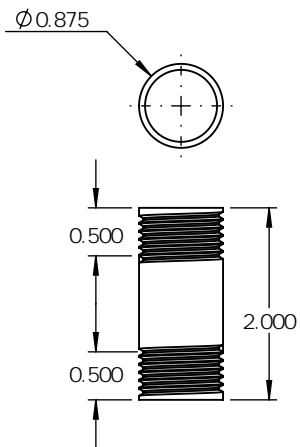

**PROPRIETARY AND CONFIDENTIAL**  
 THE INFORMATION CONTAINED IN THIS DRAWING IS THE SOLE PROPERTY OF <INSERT COMPANY NAME HERE>. ANY REPRODUCTION IN PART OR AS A WHOLE WITHOUT THE WRITTEN PERMISSION OF <INSERT COMPANY NAME HERE> IS PROHIBITED.

|  |             |   |  |           |      |  |            |         |
|--|-------------|---|--|-----------|------|--|------------|---------|
|  |             | UNLESS OTHERWISE SPECIFIED:             |  | NAME      | DATE | 7/8" ROUND ALUMINUM TUBE               |            |         |
|  |             | DIMENSIONS ARE IN INCHES<br>TOLERANCES: |  | DRAWN     |      | TITLE:                                 |            |         |
|  |             | FRACTIONAL ±                            |  | CHECKED   |      | AC P-LA -Q -SR-6-26-160W-MN-WF-DIM-27K |            |         |
|  |             | ANGULAR: MACH ± BEND ±                  |  | ENG APPR. |      | SIZE                                   | DWG. NO.   | REV     |
|  |             | TWO PLACE DECIMAL ±                     |  | MFG APPR. |      | <b>A</b>                               |            |         |
|  |             | THREE PLACE DECIMAL ±                   |  | Q.A.      |      |  | SCALE: 1:2 | WEIGHT: |
|  |             | INTERPRET GEOMETRIC TOLERANCING PER:    |  | COMMENTS: |      |  |            |         |
|  |             | MATERIAL                                |  |           |      |  |            |         |
|  | NEXT ASSY   | FINISH                                  |  |           |      |  |            |         |
|  | USED ON     |   |  |           |      |  |            |         |
|  | APPLICATION | DO NOT SCALE DRAWING                    |  |           |      |  |            |         |

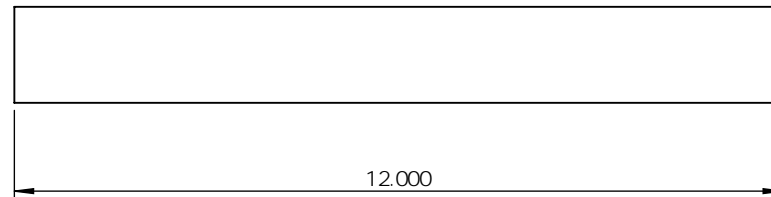
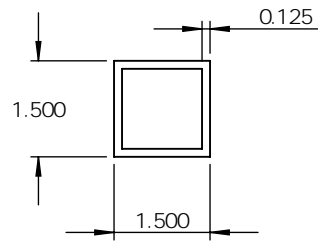
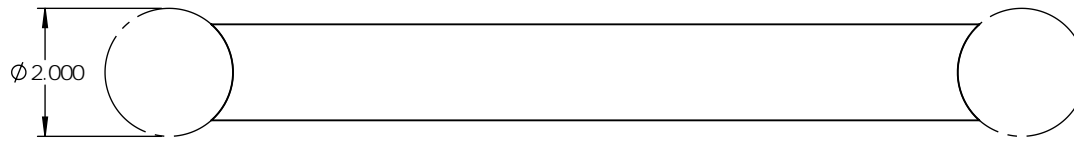
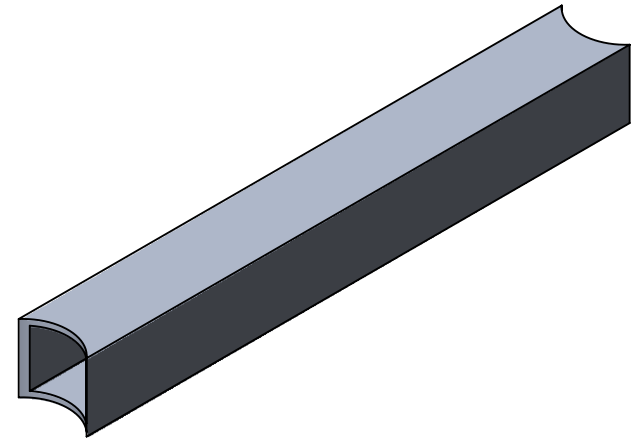

**PROPRIETARY AND CONFIDENTIAL**  
 THE INFORMATION CONTAINED IN THIS DRAWING IS THE SOLE PROPERTY OF <INSERT COMPANY NAME HERE>. ANY REPRODUCTION IN PART OR AS A WHOLE WITHOUT THE WRITTEN PERMISSION OF <INSERT COMPANY NAME HERE> IS PROHIBITED.

|             |         |   |           |      |      |
|-------------|---------|---|-----------|------|------|
|             |         | UNLESS OTHERWISE SPECIFIED:   |           | NAME | DATE |
|             |         | DIMENSIONS ARE IN INCHES<br>TOLERANCES:<br>FRACTIONAL ±<br>ANGULAR: MACH ± BEND ±<br>TWO PLACE DECIMAL ±<br>THREE PLACE DECIMAL ± | DRAWN     |      |      |
|             |         | INTERPRET GEOMETRIC TOLERANCING PER:  | CHECKED   |      |      |
|             |         | MATERIAL  | ENG APPR. |      |      |
|             |         | FINISH  | MFG APPR. |      |      |
|             |         | DO NOT SCALE DRAWING  | Q.A.      |      |      |
| NEXT ASSY   | USED ON |   | COMMENTS: |      |      |
| APPLICATION |         |   |           |      |      |

1-1/2" SQUARE ALUMINUM TUBE

TITLE:

ACP-LA-Q-SR-6-26-160W-MN-WF-DIM-27K

|            |          |                |
|------------|----------|----------------|
| SIZE       | DWG. NO. | REV            |
| <b>A</b>   |          |                |
| SCALE: 1:3 | WEIGHT:  | SHEET 15 OF 15 |