

| ITEM NO. | PART NUMBER                        | DESCRIPTION               | QTY. | CUT |
|----------|------------------------------------|---------------------------|------|-----|
| 1        | EC-ALC-B-MD-20W-5" CYLINDER        | 5" CYLINDER TUBE          | 1    |     |
| 2        | EC-ALC-B-MD-20W-SPUN TOP COVER     | SPUN ALUMINUM 0.080"      | 1    |     |
| 3        | EC-ALC-B-MD-20W-SPUN LED BRACKET   | SPUN ALUMINUM 0.080"      | 1    |     |
| 4        | EC-ALC-B-MD-20W-SPUN SEAT BOWL     | SPUN ALUMINUM 0.080"      | 1    |     |
| 5        | EC-ALC-B-MD-20W-SPUN FITTER        | SPUN ALUMINUM 0.080"      | 1    |     |
| 6        | EC-ALC-B-MD-20W-LED PLATE          | ALUMINUM 0.0635"          | 1    |     |
| 7        | EC-ALC-B-MD-20W-DRIVER BRACKET     | ALUMINUM 0.0635"          | 1    |     |
| 8        | EC-ALC-B-MD-20W-ROUND ANCHOR PLATE | ALUMINUM 0.500" PLATE     | 1    |     |
| 9        | EC-ALC-B-MD-20W-ROUND ANCHOR TAB   | ALUMINUM 0.500" PLATE     | 4    |     |
| 10       | EC-ALC-B-MD-20W-SPACER BAR ARMS    | 1/2" SQUARE ALUMINUM BAR  | 3    |     |
| 11       | EC-ALC-B-MD-20W-SPACER TUBE ARMS   | 1/2" SQUARE ALUMINUM TUBE | 1    |     |
| 12       | EC-ALC-B-MD-20W-ACRYLIC            | ACRYLIC                   | 1    |     |
| 13       | Altal_LED_PN1019_SHIM PLATE        | ALUMINUM 0.125" PLATE     | 2    |     |
| 14       | 99926A138                          | 18-8 FLAT HEAD SCREW      | 4    |     |
| 15       | 92949A194                          | 8-32 HEAD SCREW           | 8    |     |
| 16       | Altal_LED_PN1019_RevC              | LED                       | 2    |     |
| 17       | ESPEN VEL29070MVH-1                | DRIVER                    | 1    |     |

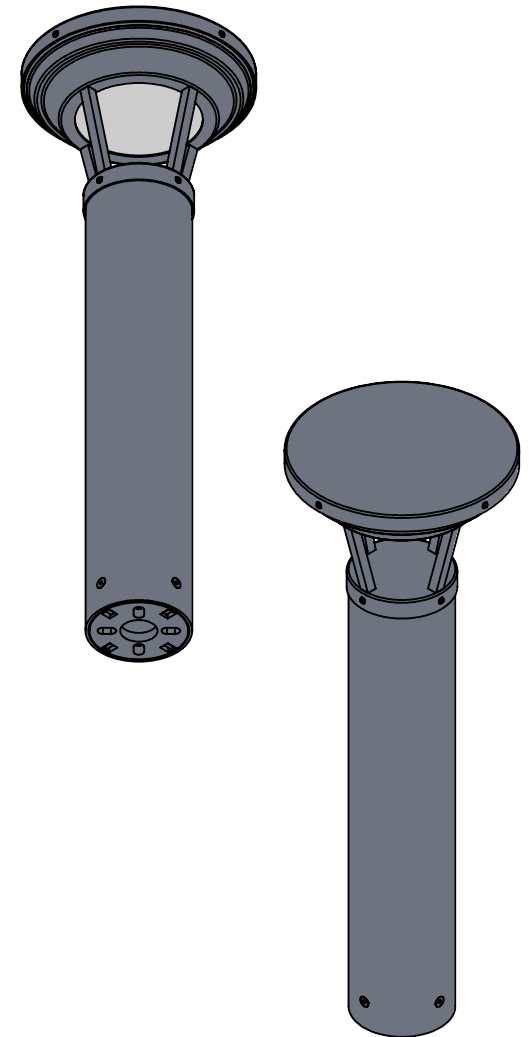

|                                                                                                                                                |           |      |                               |     |
|------------------------------------------------------------------------------------------------------------------------------------------------|-----------|------|-------------------------------|-----|
| UNLESS OTHERWISE SPECIFIED:                                                                                                                    | NAME      | DATE | TITLE:<br><br>EC-ALC-B-MD-20W |     |
| DIMENSIONS ARE IN INCHES<br>TOLERANCES:<br>FRACTIONAL ± .003<br>ANGULAR: MACH ± .01 BEND ±<br>TWO PLACE DECIMAL ±<br>THREE PLACE DECIMAL ±.001 | DRAWN     |      |                               |     |
| INTERPRET GEOMETRIC<br>TOLERANCING PER:                                                                                                        | CHECKED   |      | <b>A</b>                      | REV |
| MATERIAL                                                                                                                                       | ENG APPR. |      |                               |     |
| FINISH                                                                                                                                         | MFG APPR. |      | SHEET 1 OF 12                 |     |
| APPLICATION                                                                                                                                    | COMMENTS: |      |                               |     |
| DO NOT SCALE DRAWING                                                                                                                           |           |      |                               |     |

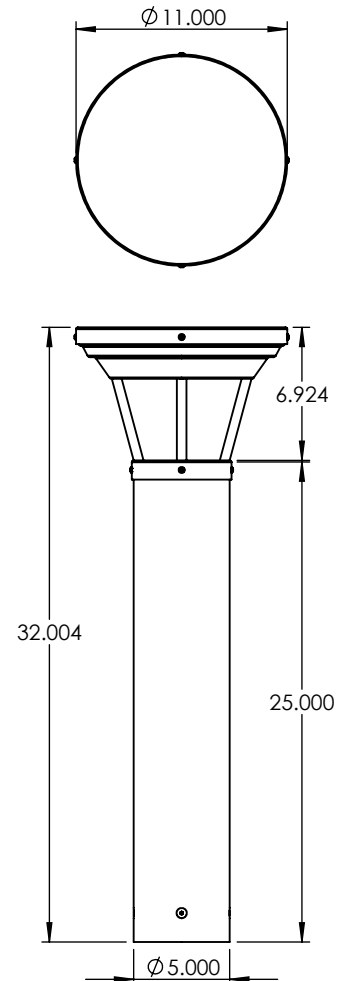

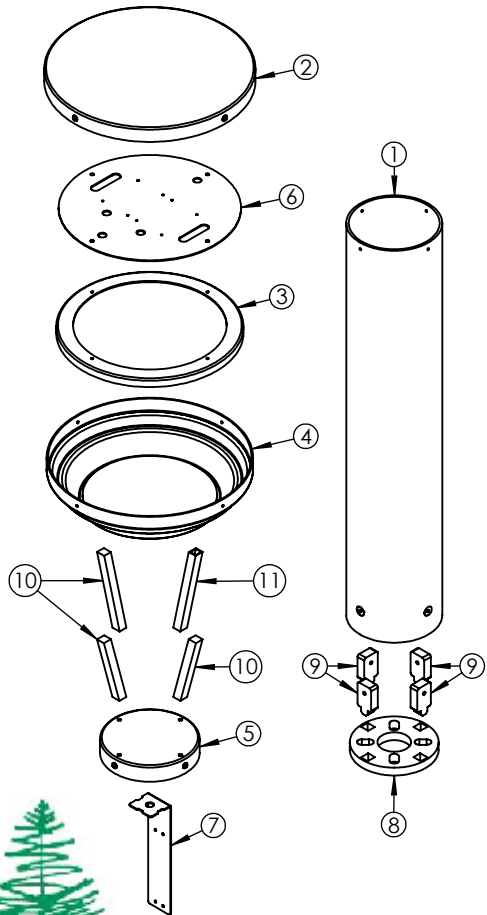
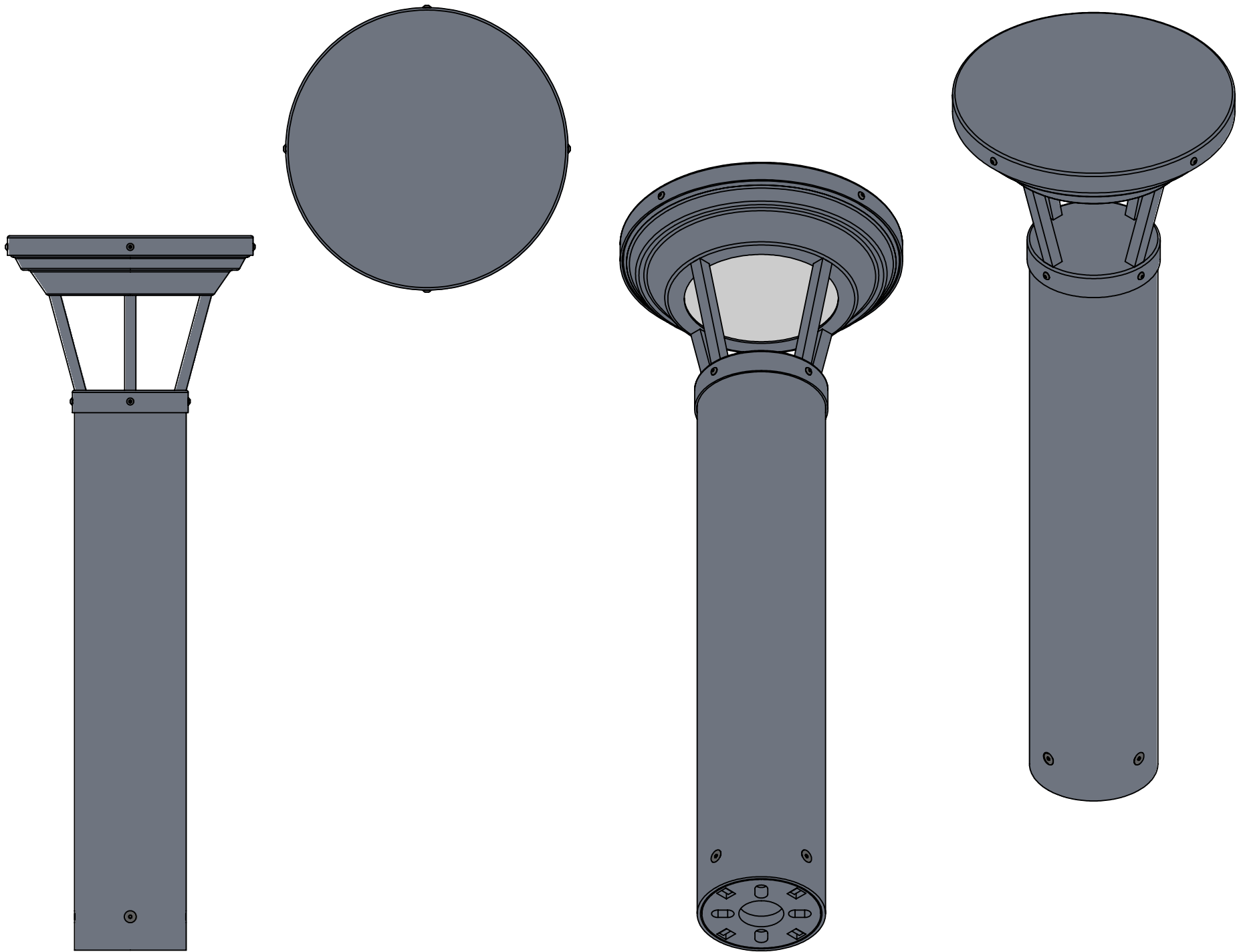

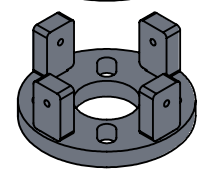
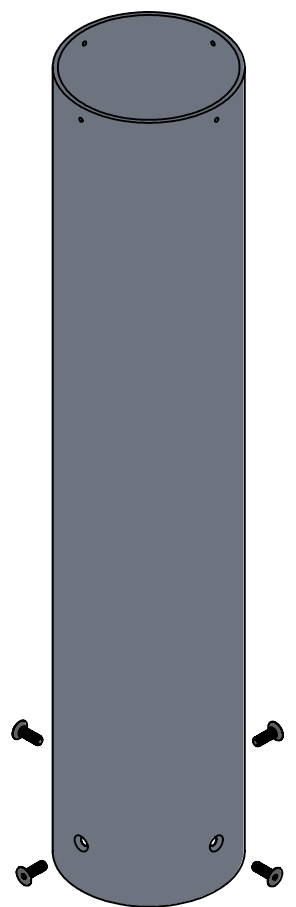
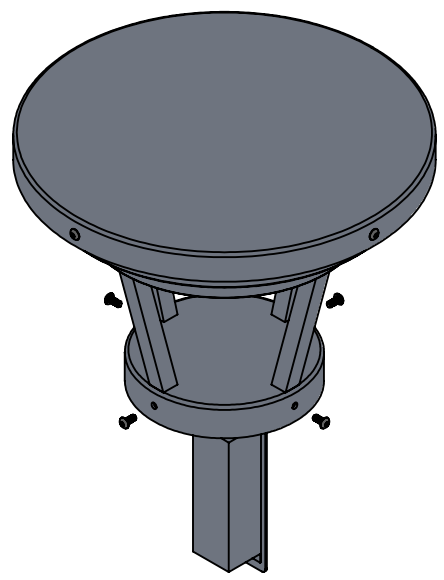
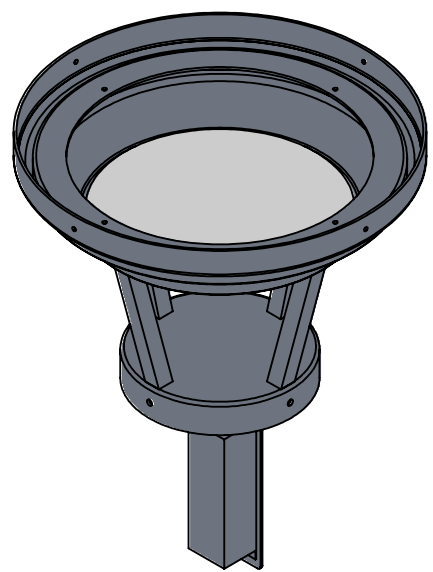
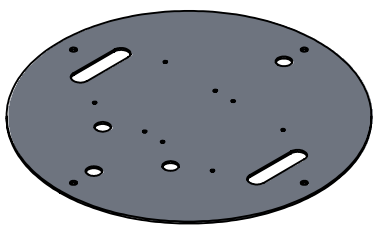
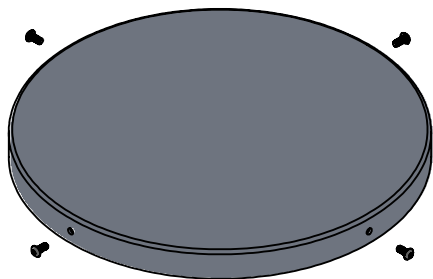

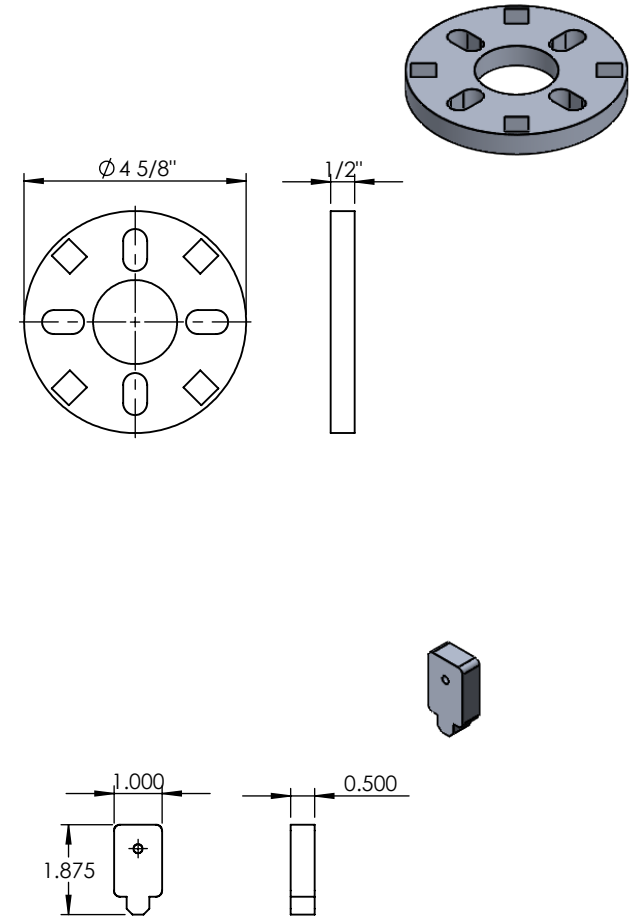
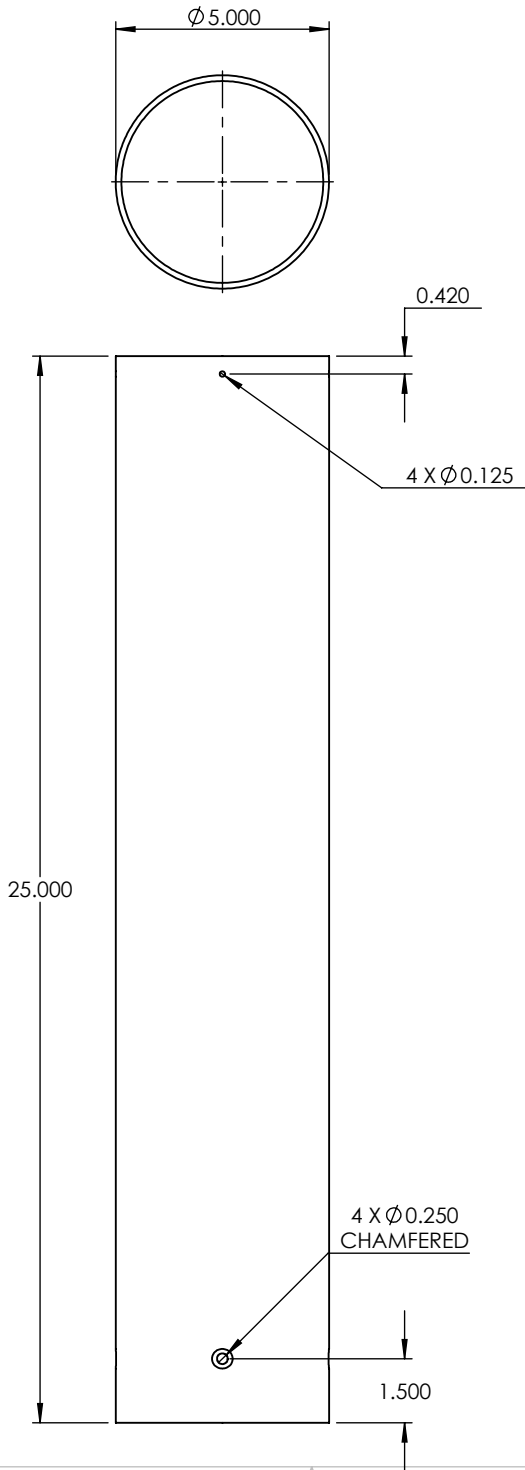

| UNLESS OTHERWISE SPECIFIED:          |  | NAME      | DATE | 5" CYLINDER TUBE              |               |
|--------------------------------------|--|-----------|------|-------------------------------|---------------|
| DIMENSIONS ARE IN INCHES             |  | DRAWN     |      | TITLE:<br><br>EC-ALC-B-MD-20W |               |
| TOLERANCES:                          |  | CHECKED   |      |                               |               |
| FRACTIONAL $\pm$                     |  | ENG APPR. |      |                               |               |
| ANGULAR: MACH $\pm$ BEND $\pm$       |  | MFG APPR. |      |                               |               |
| TWO PLACE DECIMAL $\pm$              |  | Q.A.      |      | SIZE                          | DWG. NO.      |
| THREE PLACE DECIMAL $\pm$            |  | COMMENTS: |      | <b>A</b>                      |               |
| INTERPRET GEOMETRIC TOLERANCING PER: |  |           |      | SCALE: 1:4.5                  | WEIGHT:       |
| MATERIAL                             |  |           |      |                               | SHEET 4 OF 12 |
| FINISH                               |  |           |      |                               |               |
| DO NOT SCALE DRAWING                 |  |           |      |                               |               |

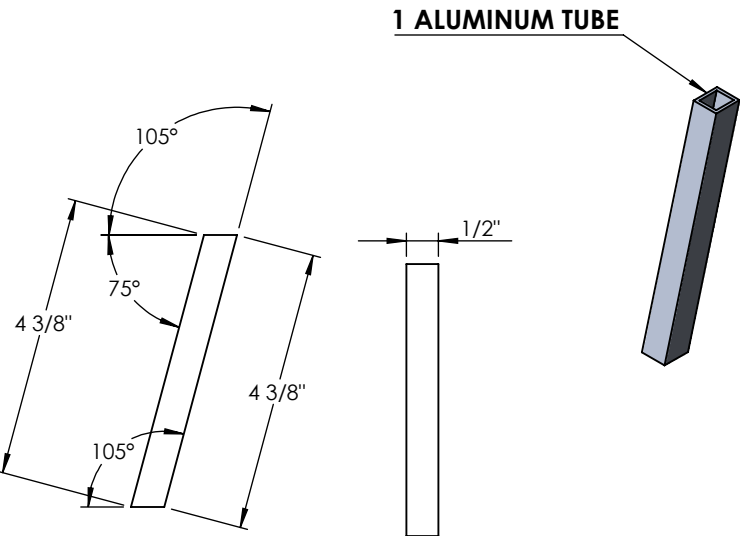
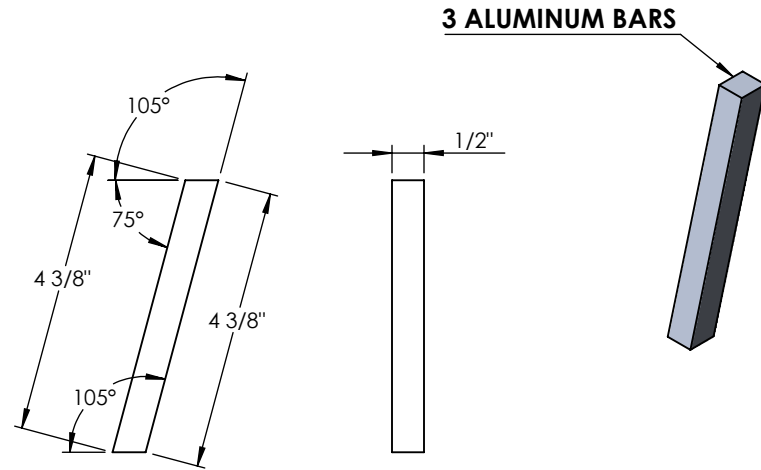

**ALL SPINNINGS AND  
TUBE/ARMS WELDED AS ONE**

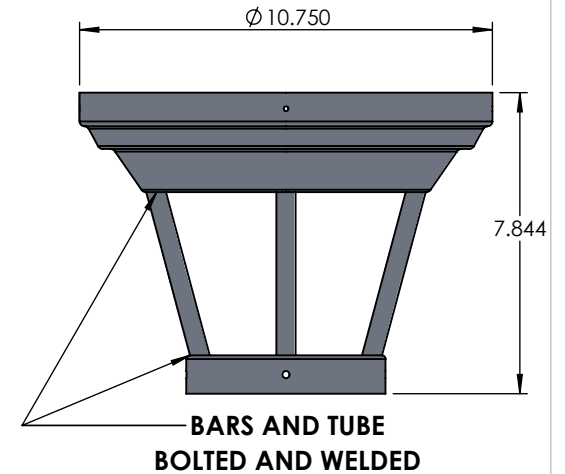
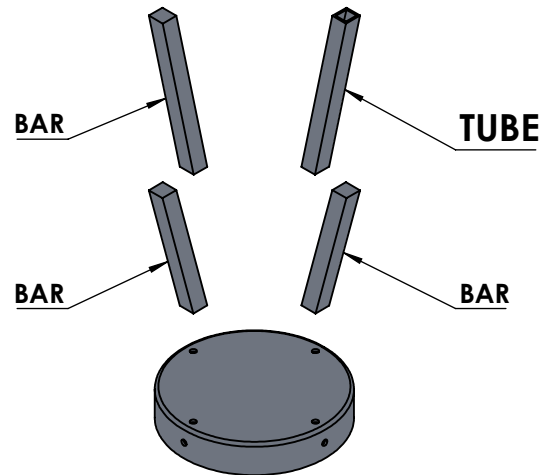
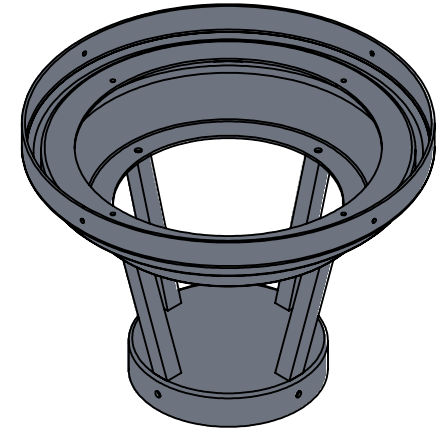
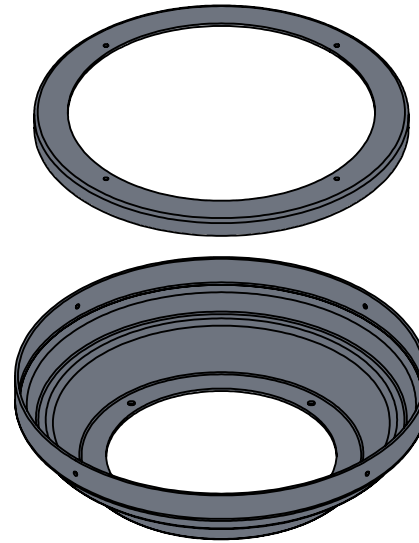

**PROPRIETARY AND CONFIDENTIAL**  
THE INFORMATION CONTAINED IN THIS DRAWING IS THE SOLE PROPERTY OF <INSERT COMPANY NAME HERE>. ANY REPRODUCTION IN PART OR AS A WHOLE WITHOUT THE WRITTEN PERMISSION OF <INSERT COMPANY NAME HERE> IS PROHIBITED.

|             |         |                                      |           |      |      |
|-------------|---------|--------------------------------------|-----------|------|------|
|             |         | UNLESS OTHERWISE SPECIFIED:          |           | NAME | DATE |
|             |         | DIMENSIONS ARE IN INCHES             | DRAWN     |      |      |
|             |         | TOLERANCES:                          | CHECKED   |      |      |
|             |         | FRACTIONAL $\pm$                     | ENG APPR. |      |      |
|             |         | ANGULAR: MACH $\pm$ BEND $\pm$       | MFG APPR. |      |      |
|             |         | TWO PLACE DECIMAL $\pm$              | Q.A.      |      |      |
|             |         | THREE PLACE DECIMAL $\pm$            | COMMENTS: |      |      |
|             |         | INTERPRET GEOMETRIC TOLERANCING PER: |           |      |      |
|             |         | MATERIAL                             |           |      |      |
| NEXT ASSY   | USED ON | FINISH                               |           |      |      |
| APPLICATION |         | DO NOT SCALE DRAWING                 |           |      |      |

**1/2" SQUARE ALUMINUM BAR**

TITLE:  
**EC-ALC-B-MD-20W**

|                  |          |     |
|------------------|----------|-----|
| SIZE<br><b>A</b> | DWG. NO. | REV |
|------------------|----------|-----|

|            |         |               |
|------------|---------|---------------|
| SCALE: 1:3 | WEIGHT: | SHEET 5 OF 12 |
|------------|---------|---------------|

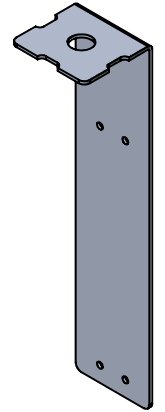
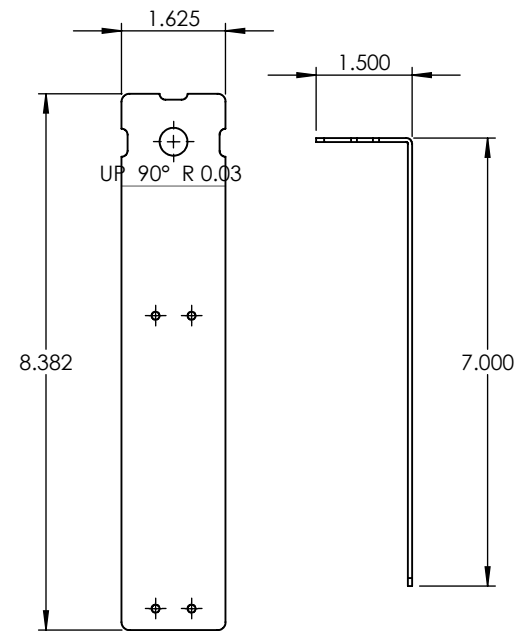
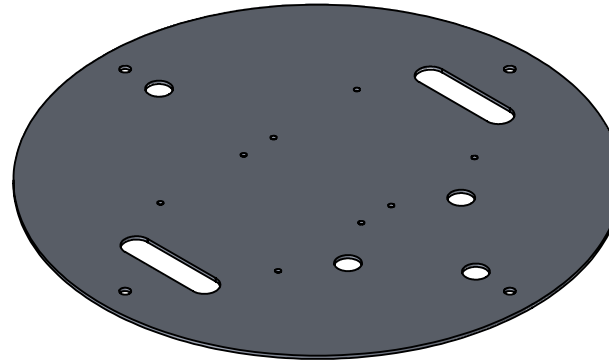
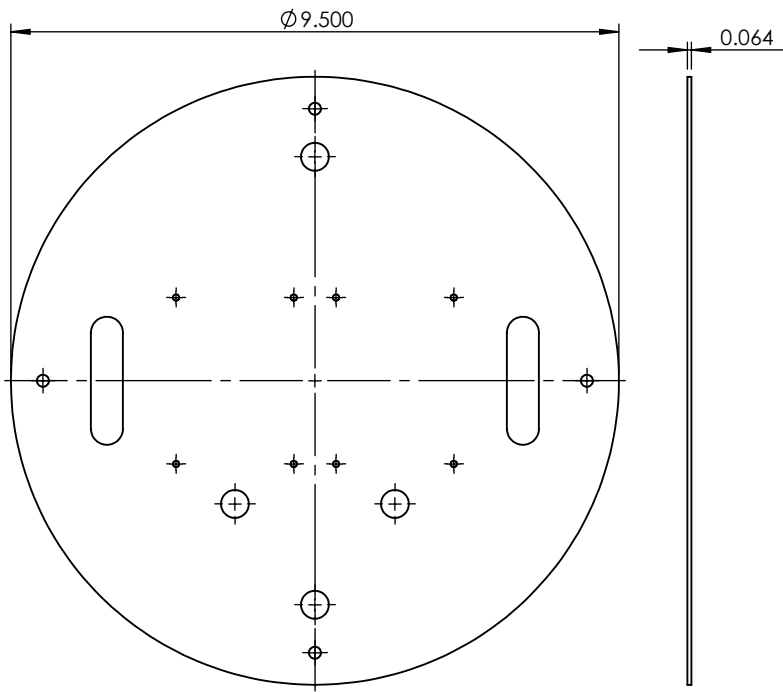

**PROPRIETARY AND CONFIDENTIAL**  
 THE INFORMATION CONTAINED IN THIS DRAWING IS THE SOLE PROPERTY OF <INSERT COMPANY NAME HERE>. ANY REPRODUCTION IN PART OR AS A WHOLE WITHOUT THE WRITTEN PERMISSION OF <INSERT COMPANY NAME HERE> IS PROHIBITED.

|           |         |                                      |           |      |                               |               |
|-----------|---------|--------------------------------------|-----------|------|-------------------------------|---------------|
|           |         | UNLESS OTHERWISE SPECIFIED:          | NAME      | DATE | ALUMINUM 0.0635"              |               |
|           |         | DIMENSIONS ARE IN INCHES             | DRAWN     |      | TITLE:<br><br>EC-ALC-B-MD-20W |               |
|           |         | TOLERANCES:                          | CHECKED   |      |                               |               |
|           |         | FRACTIONAL ±                         | ENG APPR. |      |                               |               |
|           |         | ANGULAR: MACH ± BEND ±               | MFG APPR. |      |                               |               |
|           |         | TWO PLACE DECIMAL ±                  | Q.A.      |      | SIZE                          | DWG. NO.      |
|           |         | THREE PLACE DECIMAL ±                | COMMENTS: |      | <b>A</b>                      |               |
|           |         | INTERPRET GEOMETRIC TOLERANCING PER: |           |      | SCALE: 1:3                    | WEIGHT:       |
|           |         | MATERIAL                             |           |      |                               | SHEET 6 OF 12 |
|           |         | FINISH                               |           |      |                               |               |
| NEXT ASSY | USED ON | APPLICATION                          |           |      |                               |               |
|           |         | DO NOT SCALE DRAWING                 |           |      |                               |               |

5

4

3

2

1

| ITEM NO. | PART NUMBER                 | DESCRIPTION          | QTY. |
|----------|-----------------------------|----------------------|------|
| 1        | EC-ALC-B-MD-20W-SPUN FITTER | SPUN ALUMINUM 0.080" | 1    |

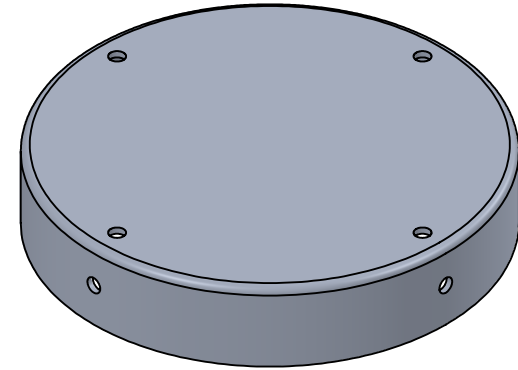
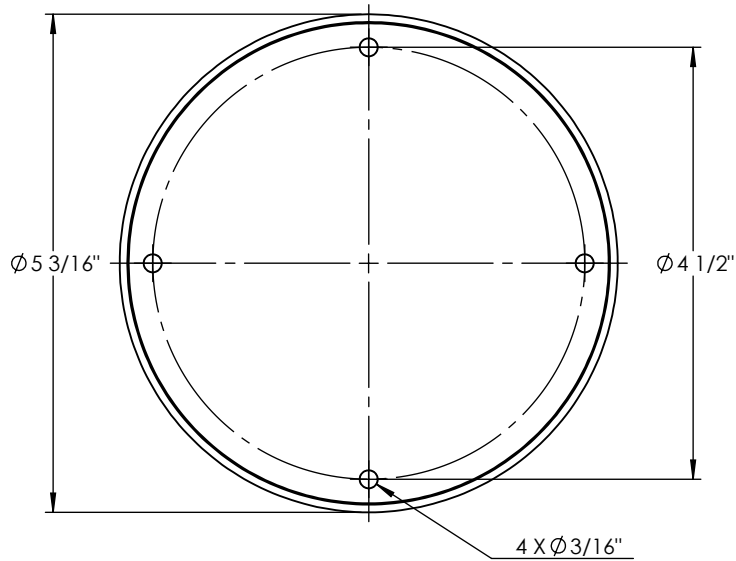
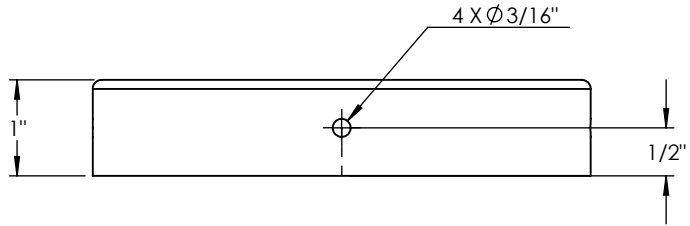

**PROPRIETARY AND CONFIDENTIAL**  
 THE INFORMATION CONTAINED IN THIS DRAWING IS THE SOLE PROPERTY OF <INSERT COMPANY NAME HERE>. ANY REPRODUCTION IN PART OR AS A WHOLE WITHOUT THE WRITTEN PERMISSION OF <INSERT COMPANY NAME HERE> IS PROHIBITED.

|             |         | UNLESS OTHERWISE SPECIFIED:                                                                                                                           | NAME      | DATE |
|-------------|---------|-------------------------------------------------------------------------------------------------------------------------------------------------------|-----------|------|
|             |         | DIMENSIONS ARE IN INCHES<br>TOLERANCES:<br>FRACTIONAL $\pm$<br>ANGULAR: MACH $\pm$ BEND $\pm$<br>TWO PLACE DECIMAL $\pm$<br>THREE PLACE DECIMAL $\pm$ | DRAWN     |      |
|             |         | INTERPRET GEOMETRIC TOLERANCING PER:                                                                                                                  | CHECKED   |      |
|             |         | MATERIAL                                                                                                                                              | ENG APPR. |      |
|             |         | FINISH                                                                                                                                                | MFG APPR. |      |
| NEXT ASSY   | USED ON |                                                                                                                                                       | Q.A.      |      |
| APPLICATION |         | DO NOT SCALE DRAWING                                                                                                                                  | COMMENTS: |      |

| TITLE:               |          |               |
|----------------------|----------|---------------|
| SPUN ALUMINUM 0.080" |          |               |
| EC-ALC-B-MD-20W      |          |               |
| SIZE                 | DWG. NO. | REV           |
| <b>A</b>             |          |               |
| SCALE: 1:2           | WEIGHT:  | SHEET 7 OF 12 |

| ITEM NO. | PART NUMBER                    | DESCRIPTION          | QTY. |
|----------|--------------------------------|----------------------|------|
| 1        | EC-ALC-B-MD-20W-SPUN SEAT BOWL | SPUN ALUMINUM 0.080" | 1    |

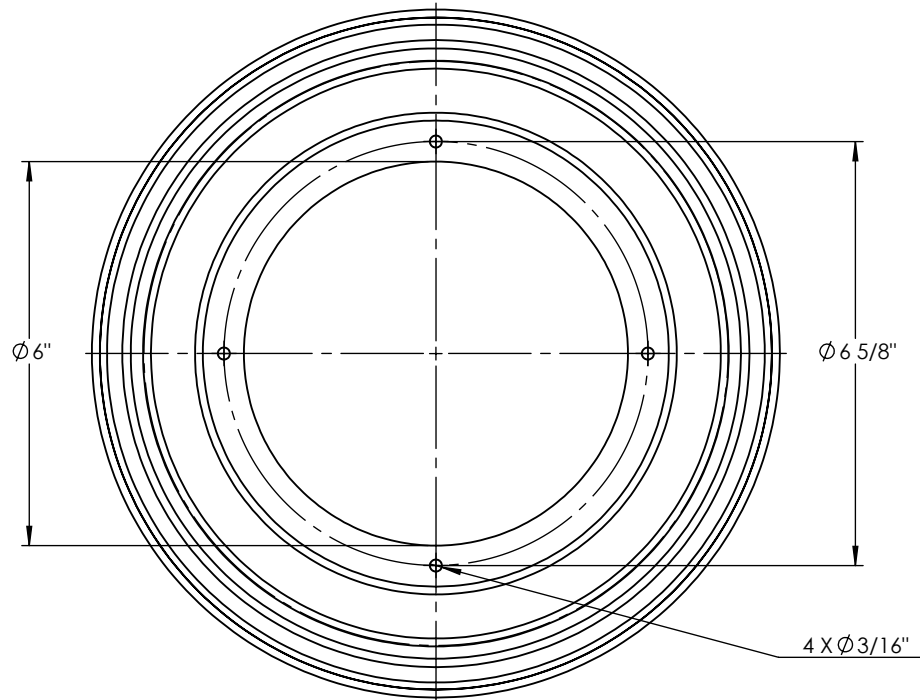
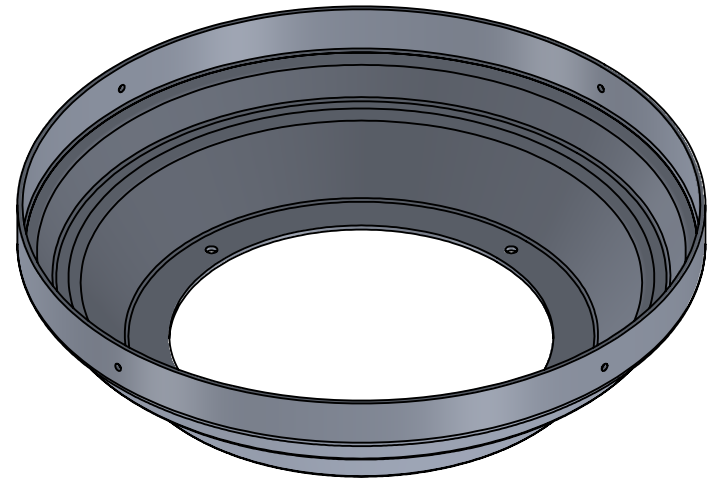
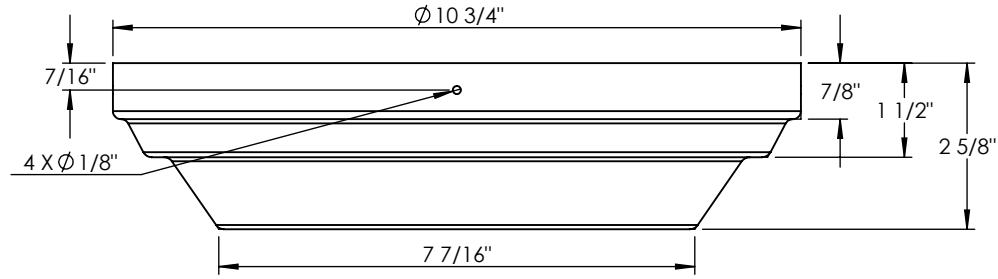

**PROPRIETARY AND CONFIDENTIAL**  
 THE INFORMATION CONTAINED IN THIS DRAWING IS THE SOLE PROPERTY OF <INSERT COMPANY NAME HERE>. ANY REPRODUCTION IN PART OR AS A WHOLE WITHOUT THE WRITTEN PERMISSION OF <INSERT COMPANY NAME HERE> IS PROHIBITED.

| UNLESS OTHERWISE SPECIFIED:          |                      | NAME      | DATE |
|--------------------------------------|----------------------|-----------|------|
| DIMENSIONS ARE IN INCHES             |                      | DRAWN     |      |
| TOLERANCES:                          |                      | CHECKED   |      |
| FRACTIONAL ±                         |                      | ENG APPR. |      |
| ANGULAR: MACH ± BEND ±               |                      | MFG APPR. |      |
| TWO PLACE DECIMAL ±                  |                      | Q.A.      |      |
| THREE PLACE DECIMAL ±                |                      | COMMENTS: |      |
| INTERPRET GEOMETRIC TOLERANCING PER: |                      |           |      |
| MATERIAL                             |                      |           |      |
| FINISH                               |                      |           |      |
| NEXT ASSY                            | USED ON              |           |      |
| APPLICATION                          | DO NOT SCALE DRAWING |           |      |

| SPUN ALUMINUM 0.080" |          |               |  |
|----------------------|----------|---------------|--|
| TITLE:               |          |               |  |
| EC-ALC-B-MD-20W      |          |               |  |
| SIZE                 | DWG. NO. | REV           |  |
| <b>A</b>             |          |               |  |
| SCALE: 1:3           | WEIGHT:  | SHEET 8 OF 12 |  |

5

4

3

2

1



| ITEM NO. | PART NUMBER                    | DESCRIPTION          | QTY. |
|----------|--------------------------------|----------------------|------|
| 1        | EC-ALC-B-MD-20W-SPUN TOP COVER | SPUN ALUMINUM 0.080" | 1    |

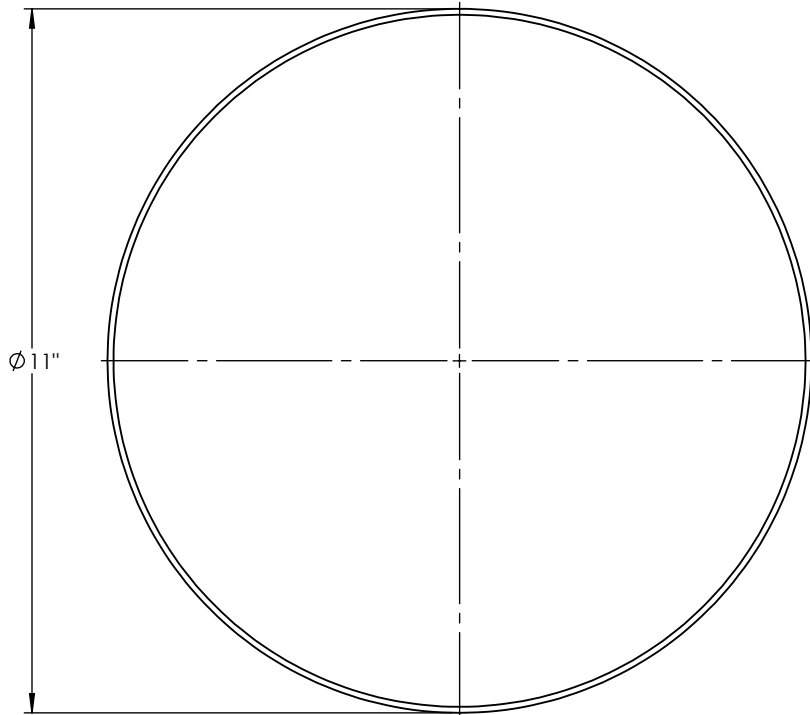
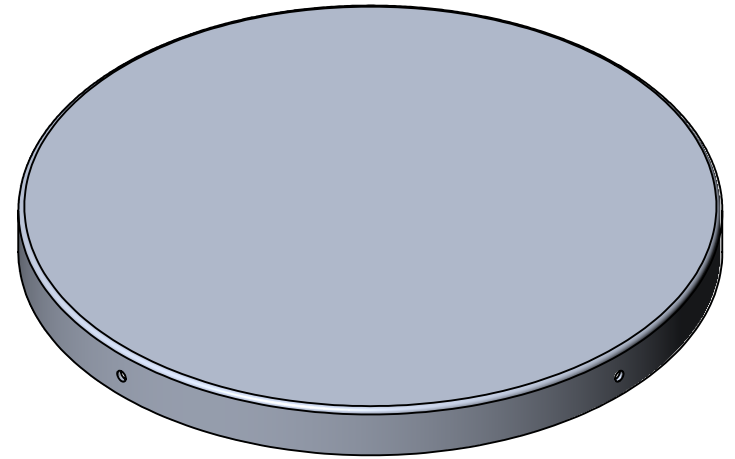
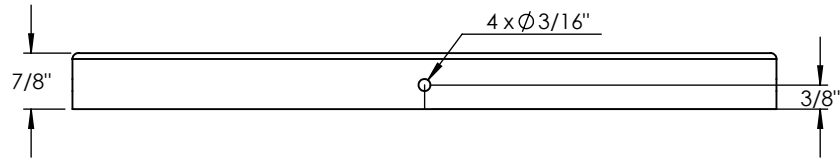

**PROPRIETARY AND CONFIDENTIAL**  
 THE INFORMATION CONTAINED IN THIS DRAWING IS THE SOLE PROPERTY OF <INSERT COMPANY NAME HERE>. ANY REPRODUCTION IN PART OR AS A WHOLE WITHOUT THE WRITTEN PERMISSION OF <INSERT COMPANY NAME HERE> IS PROHIBITED.

|           |         |                                                                                                                                   |           |           |                      |          |               |
|-----------|---------|-----------------------------------------------------------------------------------------------------------------------------------|-----------|-----------|----------------------|----------|---------------|
|           |         | UNLESS OTHERWISE SPECIFIED:                                                                                                       | NAME      | DATE      | SPUN ALUMINUM 0.080" |          |               |
|           |         | DIMENSIONS ARE IN INCHES<br>TOLERANCES:<br>FRACTIONAL ±<br>ANGULAR: MACH ± BEND ±<br>TWO PLACE DECIMAL ±<br>THREE PLACE DECIMAL ± | DRAWN     |           |                      |          | TITLE:        |
|           |         | INTERPRET GEOMETRIC TOLERANCING PER:                                                                                              | CHECKED   |           | EC-ALC-B-MD-20W      |          |               |
|           |         | MATERIAL                                                                                                                          | ENG APPR. |           |                      |          |               |
|           |         | FINISH                                                                                                                            | MFG APPR. |           | SIZE                 | DWG. NO. | REV           |
| NEXT ASSY | USED ON | APPLICATION                                                                                                                       | Q.A.      | COMMENTS: |                      |          |               |
|           |         | DO NOT SCALE DRAWING                                                                                                              |           |           | SCALE: 1:3           | WEIGHT:  | SHEET 9 OF 12 |

| ITEM NO. | PART NUMBER                    | DESCRIPTION          | QTY. |
|----------|--------------------------------|----------------------|------|
| 1        | EC-ALC-B-MD-20W-SPUN TOP COVER | SPUN ALUMINUM 0.080" | 1    |

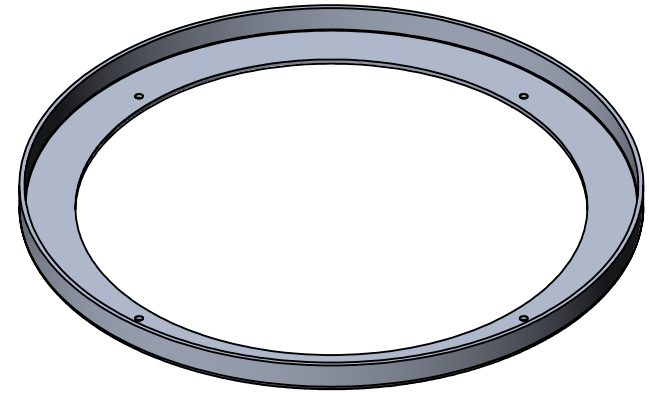
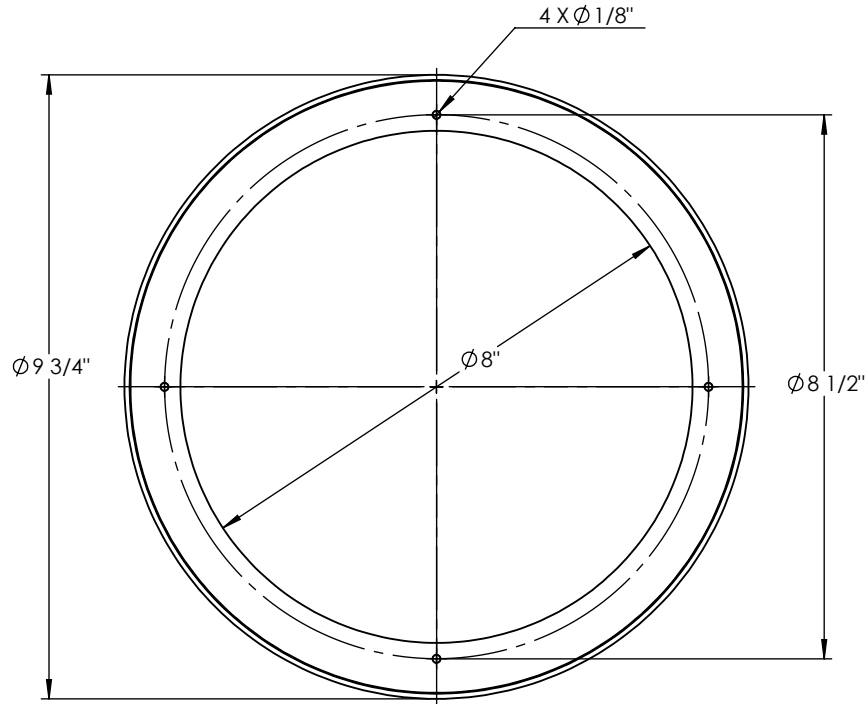
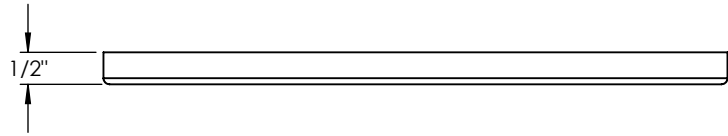

**PROPRIETARY AND CONFIDENTIAL**  
 THE INFORMATION CONTAINED IN THIS DRAWING IS THE SOLE PROPERTY OF <INSERT COMPANY NAME HERE>. ANY REPRODUCTION IN PART OR AS A WHOLE WITHOUT THE WRITTEN PERMISSION OF <INSERT COMPANY NAME HERE> IS PROHIBITED.

|             |         |                                                                                                                                   |           |      |                      |          |
|-------------|---------|-----------------------------------------------------------------------------------------------------------------------------------|-----------|------|----------------------|----------|
|             |         | UNLESS OTHERWISE SPECIFIED:                                                                                                       | NAME      | DATE | SPUN ALUMINUM 0.080" |          |
|             |         | DIMENSIONS ARE IN INCHES<br>TOLERANCES:<br>FRACTIONAL ±<br>ANGULAR: MACH ± BEND ±<br>TWO PLACE DECIMAL ±<br>THREE PLACE DECIMAL ± | DRAWN     |      | TITLE:               |          |
|             |         | INTERPRET GEOMETRIC TOLERANCING PER:                                                                                              | CHECKED   |      | EC-ALC-B-MD-20W      |          |
|             |         | MATERIAL                                                                                                                          | ENG APPR. |      | SIZE                 | DWG. NO. |
|             |         | FINISH                                                                                                                            | MFG APPR. |      | <b>A</b>             | REV      |
| NEXT ASSY   | USED ON | COMMENTS:                                                                                                                         | Q.A.      |      | SCALE: 1:3           | WEIGHT:  |
| APPLICATION |         | DO NOT SCALE DRAWING                                                                                                              |           |      | SHEET 10 OF 12       |          |

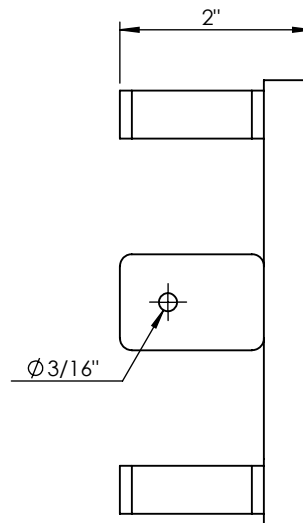
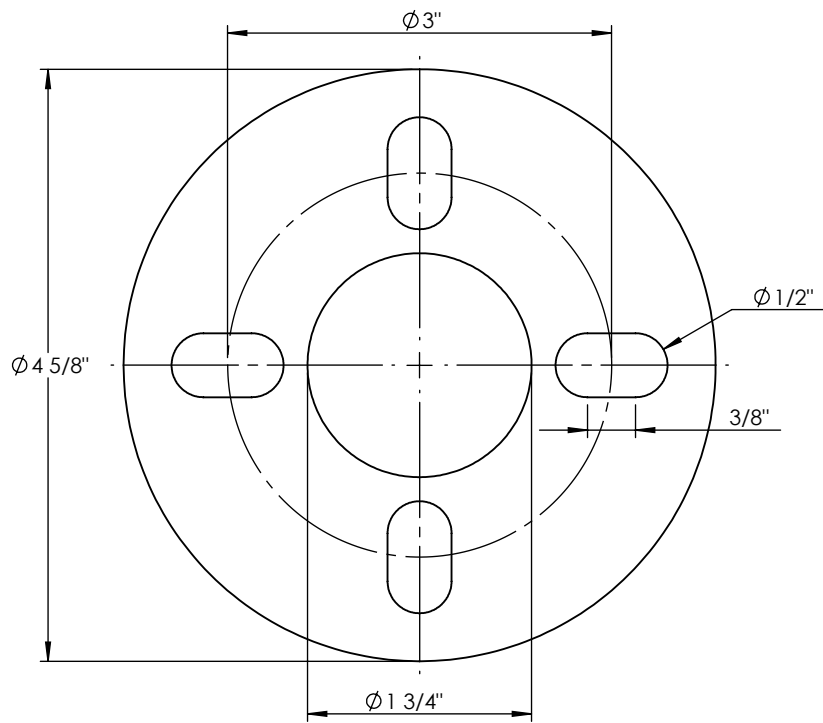
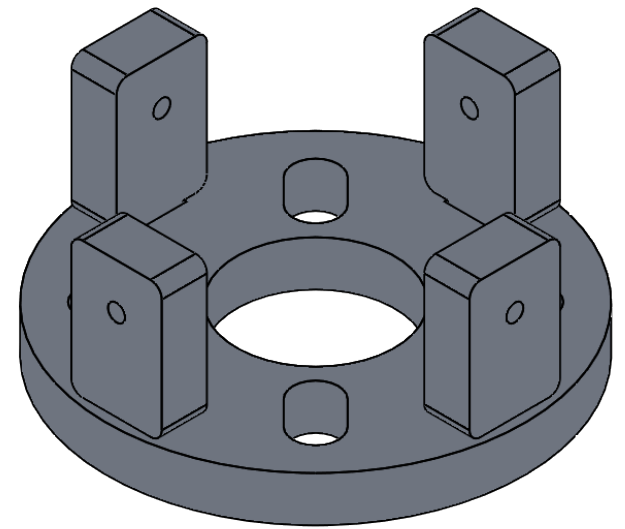

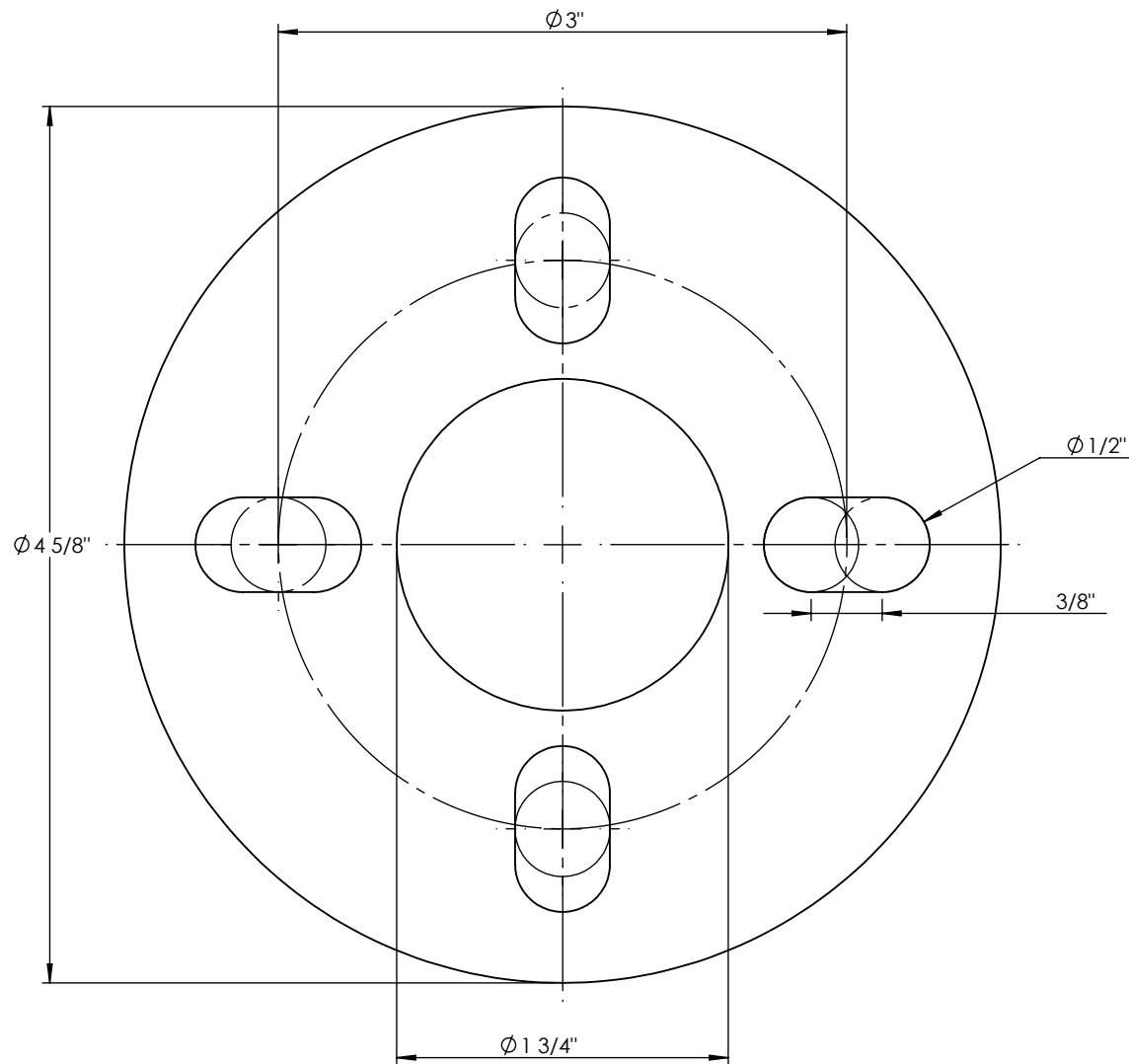

**3/8" X 12" LONG  
ANCHOR BOLT SIZE**