

ITEM NO.	PART NUMBER	DESCRIPTION	QTY.	CUT
1	EC-ARG-B-32-12W-POST	5"X5" POST	1	
2	EC-ARG-B-32-12W-POST HEAD	5"X5" POST	1	
3	EC-ARG-B-32-12W-ANCHOR BASE	ALUMINUM 0.125" PLATE	1	
4	EC-ARG-B-32-12W-POST CAP	ALUMINUM 0.125" PLATE	1	
5	EC-ARG-B-32-12W-POST CAP BRACKET	ALUMINUM 0.0635"	1	
6	EC-ARG-B-32-12W-LED PLATE	ALUMINUM 0.0635"	1	
7	EC-ARG-B-32-12W-DRIVER BRACKET	ALUMINUM 0.0635"	1	
8	EC-ARG-B-32-12W-DRIVER BOX	ALUMINUM 0.0635"	1	
9	EC-ARG-B-32-12W-BOX CAP	ALUMINUM 0.0635"	1	
10	EC-ARG-B-32-12W-SPUN DOOR	SPUN ALUMINUM 0.0635"	1	
11	EC-ARG-B-32-12W-TOP TUBE SEAT	ALUMINUM 0.125" PLATE	1	
12	EC-ARG-B-32-12W-BOTTOM TUBE SEAT	ALUMINUM 0.250" PLATE	1	
13	EC-ARG-B-32-12W-FRAME TUBE	1" SQUARE ALUMINUM TUBE	4	
14	EC-ARG-B-32-12W-INNER TUBE	3/4" SQUARE ALUMINUM TUBE	8	
15	EC-ARG-B-32-12W-LENS	ACRYLIC	1	
16	55MM HEXAGON HEAT SINK	HEAT SINK	1	
17	EspenTECH_120277V_SKU808076	DRIVER	1	
18	Alttailed PCN D1500 110B-10 WATT	LED	1	

UNLESS OTHERWISE SPECIFIED:

DIMENSIONS ARE IN INCHES
 TOLERANCES:
 FRACTIONAL ± .003
 ANGULAR: MACH ± .01 BEND ±
 TWO PLACE DECIMAL ±
 THREE PLACE DECIMAL ± .001

INTERPRET GEOMETRIC TOLERANCING PER:

MATERIAL

FINISH

	NAME	DATE
DRAWN		
CHECKED		
ENG APPR.		
MFG APPR.		
Q.A.		
COMMENTS:		

TITLE:
EC-ARG-B-32-12W

SIZE DWG. NO. REV

SCALE: 1:8 WEIGHT: SHEET 1 OF 14

EVERGREEN LIGHTING

ALL BEND RADIUS .030"

APPLICATION

DO NOT SCALE DRAWING

5

4

3

2

1

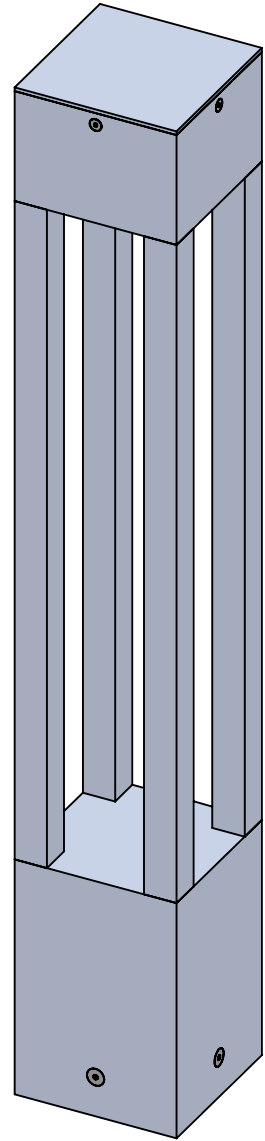
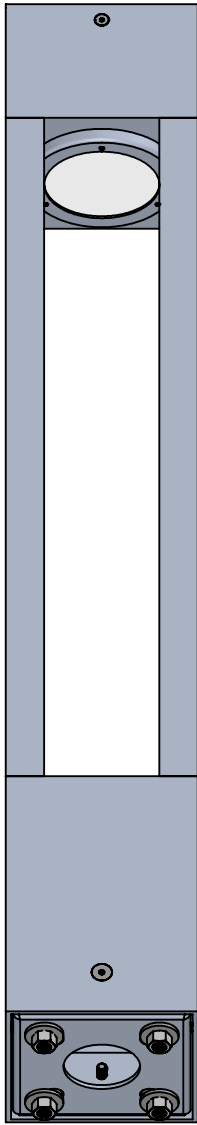
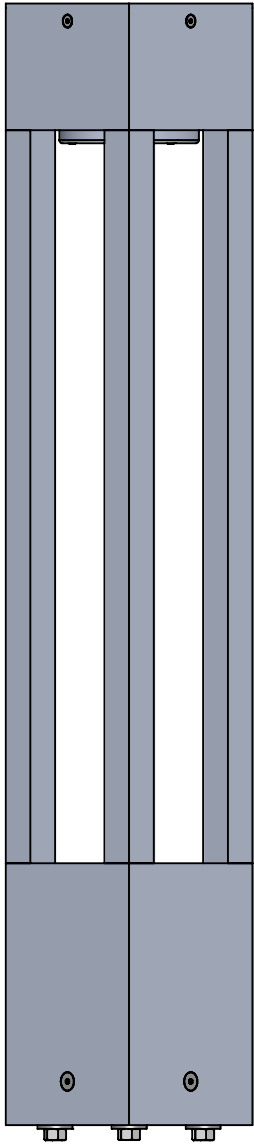

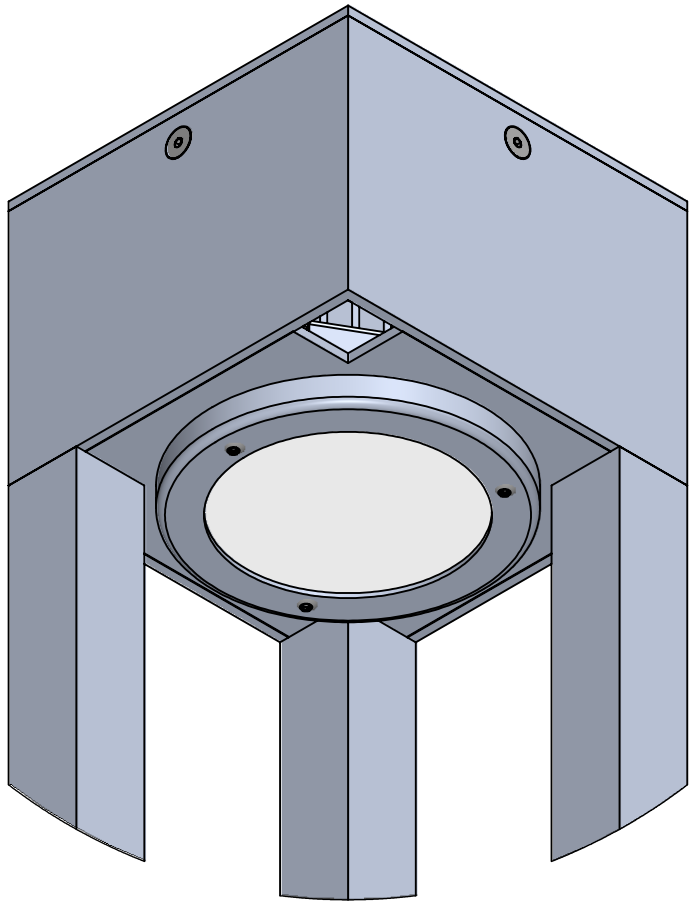

DETAIL A
SCALE 1 : 2

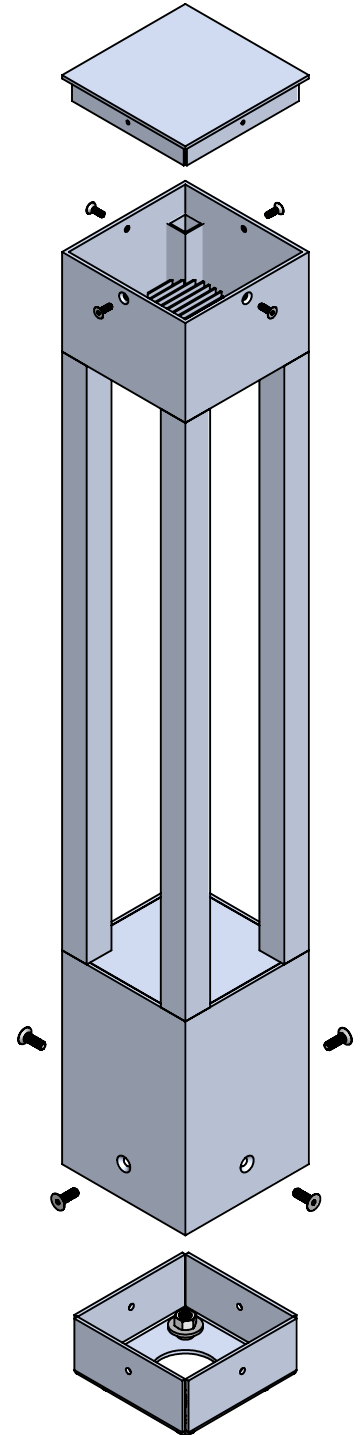
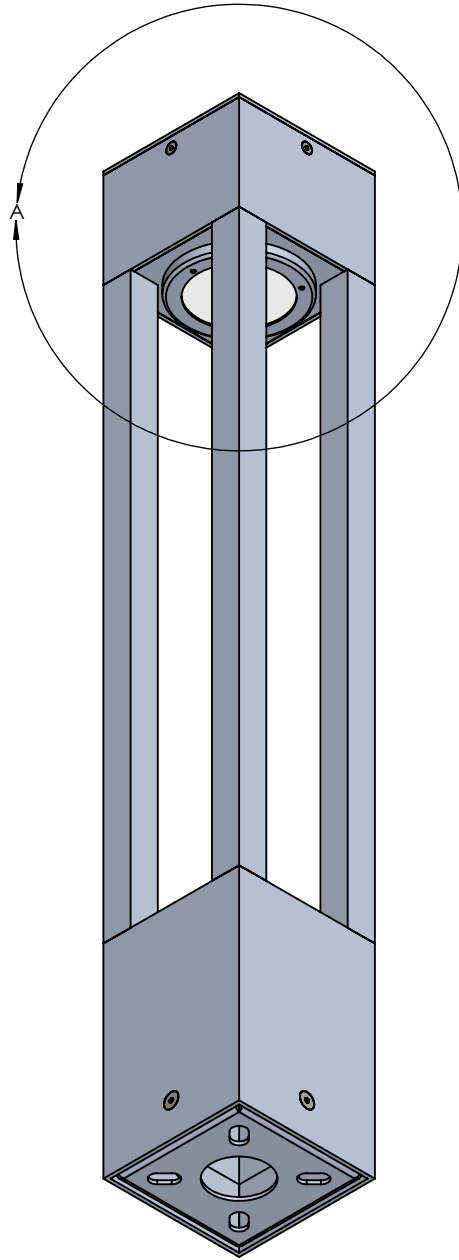

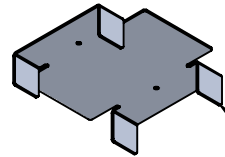
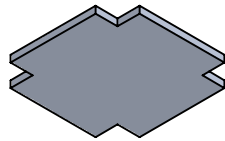
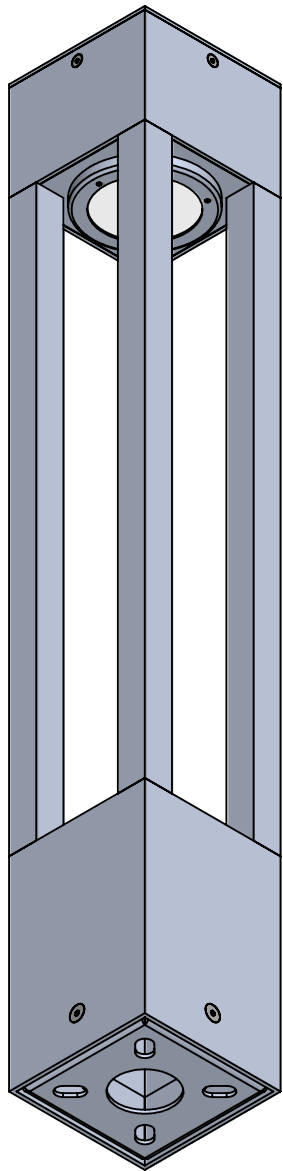

WELDED
TOGETHER

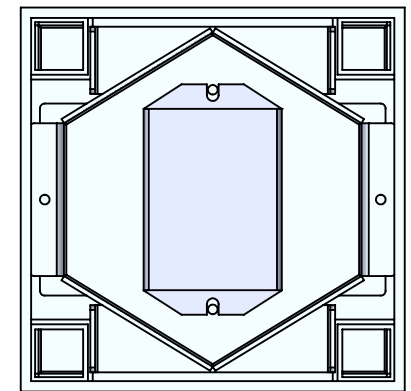
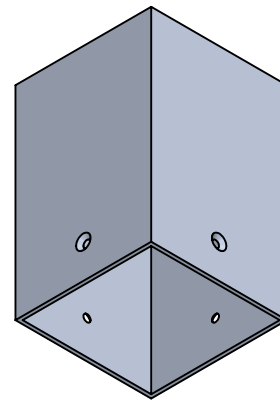
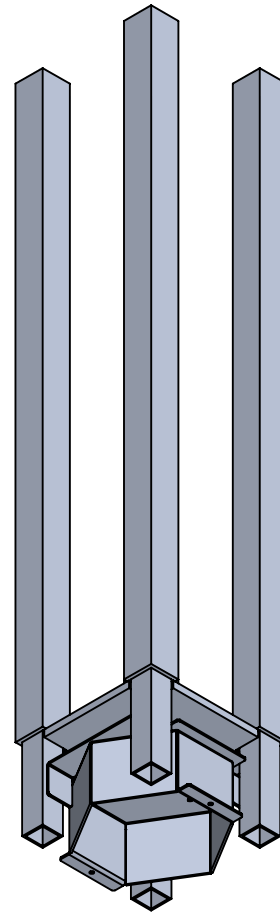
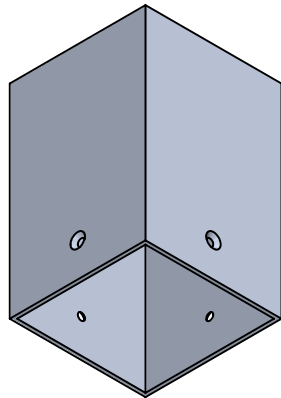
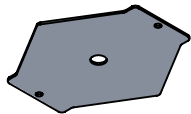
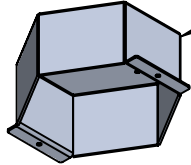

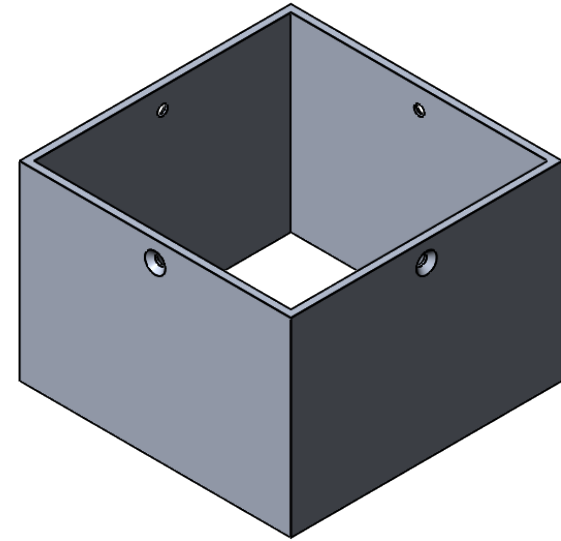
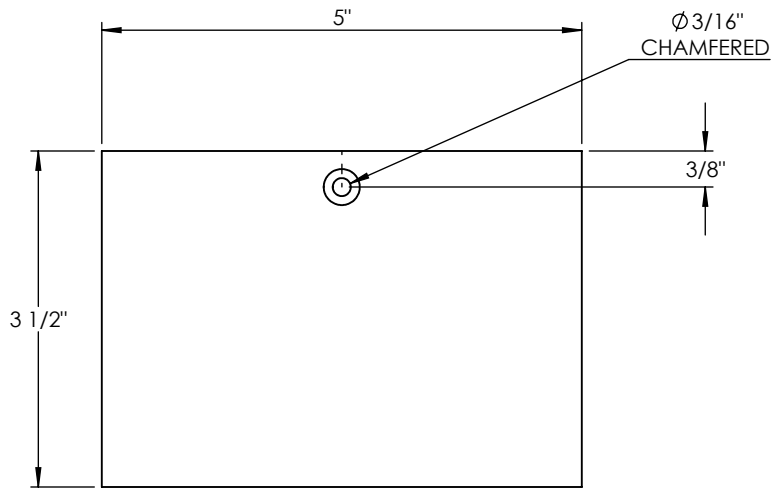

PROPRIETARY AND CONFIDENTIAL
 THE INFORMATION CONTAINED IN THIS DRAWING IS THE SOLE PROPERTY OF <INSERT COMPANY NAME HERE>. ANY REPRODUCTION IN PART OR AS A WHOLE WITHOUT THE WRITTEN PERMISSION OF <INSERT COMPANY NAME HERE> IS PROHIBITED.

NEXT ASSY	USED ON
APPLICATION	

UNLESS OTHERWISE SPECIFIED:
DIMENSIONS ARE IN INCHES
TOLERANCES:
FRACTIONAL ±
ANGULAR: MACH ± BEND ±
TWO PLACE DECIMAL ±
THREE PLACE DECIMAL ±
INTERPRET GEOMETRIC TOLERANCING PER:
MATERIAL
FINISH
DO NOT SCALE DRAWING

NAME	DATE
DRAWN	
CHECKED	
ENG APPR.	
MFG APPR.	
Q.A.	
COMMENTS:	

5"X5" POST		
TITLE:		
EC-ARG-B-32-12W		
SIZE	DWG. NO.	REV
A		
SCALE: 1:2	WEIGHT:	SHEET 5 OF 14

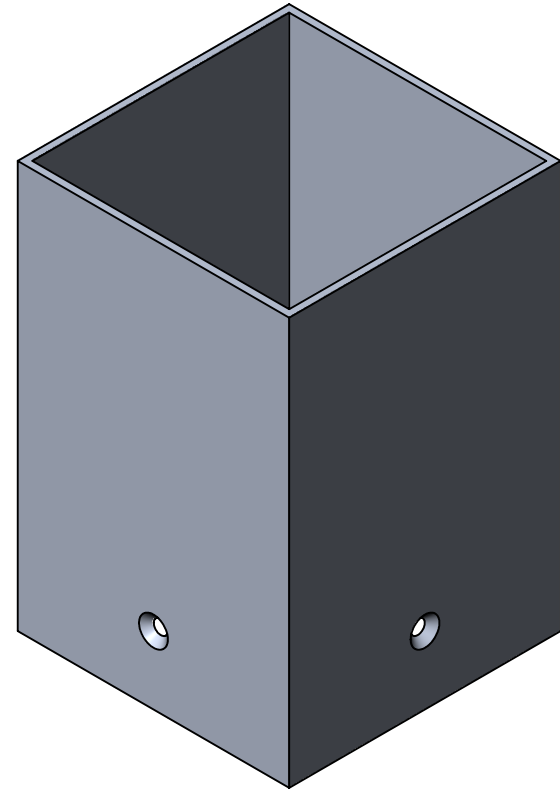
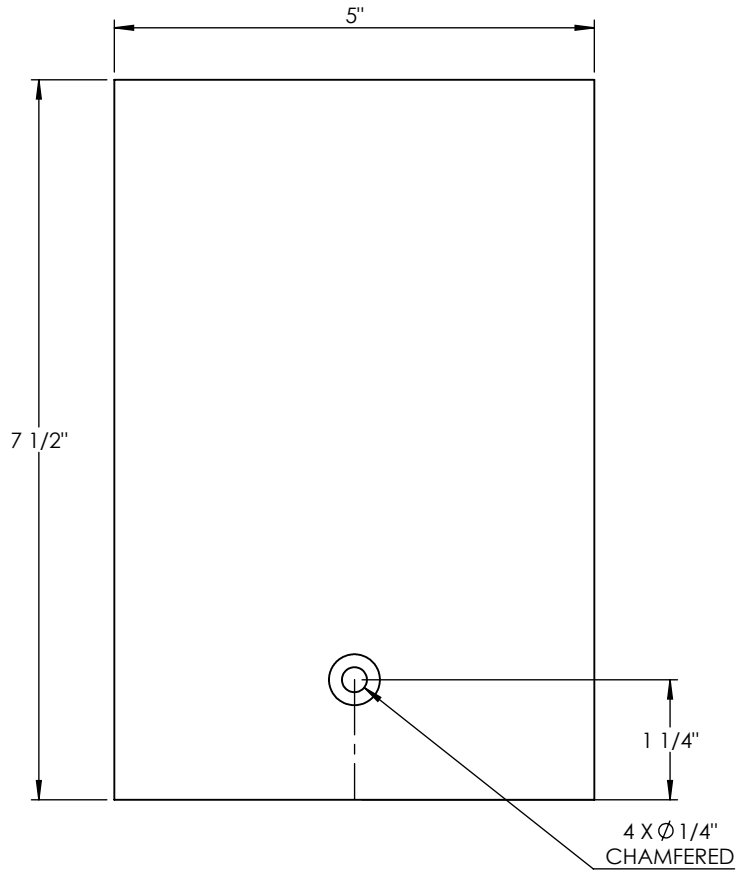

PROPRIETARY AND CONFIDENTIAL
 THE INFORMATION CONTAINED IN THIS DRAWING IS THE SOLE PROPERTY OF <INSERT COMPANY NAME HERE>. ANY REPRODUCTION IN PART OR AS A WHOLE WITHOUT THE WRITTEN PERMISSION OF <INSERT COMPANY NAME HERE> IS PROHIBITED.

NEXT ASSY	USED ON
APPLICATION	

UNLESS OTHERWISE SPECIFIED:
DIMENSIONS ARE IN INCHES
TOLERANCES:
FRACTIONAL ±
ANGULAR: MACH ± BEND ±
TWO PLACE DECIMAL ±
THREE PLACE DECIMAL ±
INTERPRET GEOMETRIC TOLERANCING PER:
MATERIAL
FINISH
DO NOT SCALE DRAWING

NAME	DATE
DRAWN	
CHECKED	
ENG APPR.	
MFG APPR.	
Q.A.	
COMMENTS:	

5"X5" POST		
TITLE:		
EC-ARG-B-32-12W		
SIZE	DWG. NO.	REV
A		
SCALE: 1:2	WEIGHT:	SHEET 6 OF 14

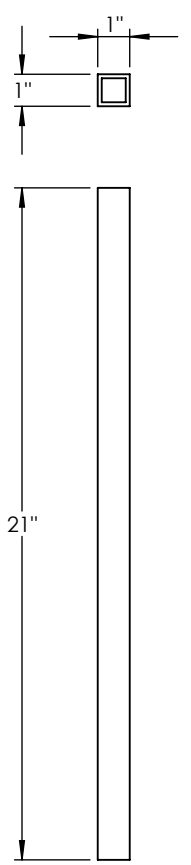
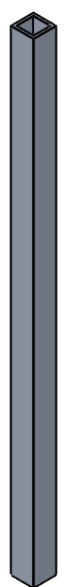
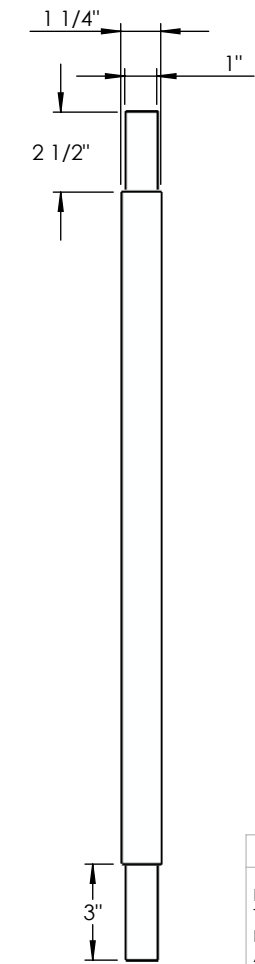
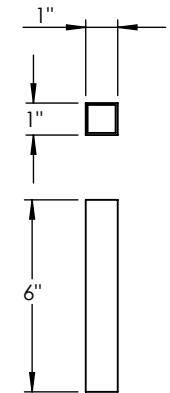
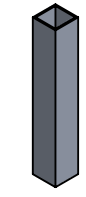
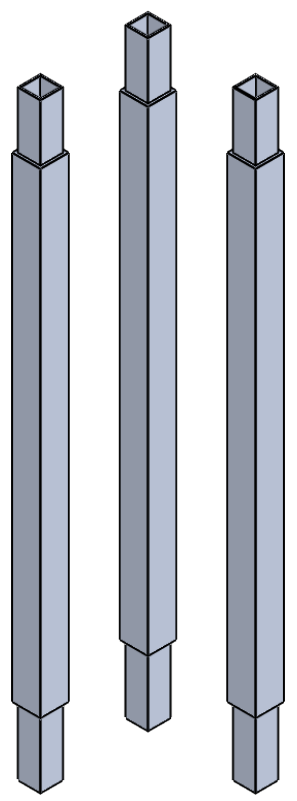

UNLESS OTHERWISE SPECIFIED:		NAME	DATE	1" SQUARE ALUMINUM TUBE		
DIMENSIONS ARE IN INCHES		DRAWN				TITLE: EC-ARG-B-32-12W
TOLERANCES:		CHECKED				
FRACTIONAL ±		ENG APPR.				
ANGULAR: MACH ± BEND ±		MFG APPR.				
TWO PLACE DECIMAL ±		Q.A.		SIZE	DWG. NO.	REV
THREE PLACE DECIMAL ±		COMMENTS:		A		
INTERPRET GEOMETRIC TOLERANCING PER:				SCALE: 1:6	WEIGHT:	SHEET 7 OF 14
MATERIAL						
FINISH						
NEXT ASSY		USED ON				
APPLICATION		DO NOT SCALE DRAWING				

PROPRIETARY AND CONFIDENTIAL
 THE INFORMATION CONTAINED IN THIS DRAWING IS THE SOLE PROPERTY OF <INSERT COMPANY NAME HERE>. ANY REPRODUCTION IN PART OR AS A WHOLE WITHOUT THE WRITTEN PERMISSION OF <INSERT COMPANY NAME HERE> IS PROHIBITED.

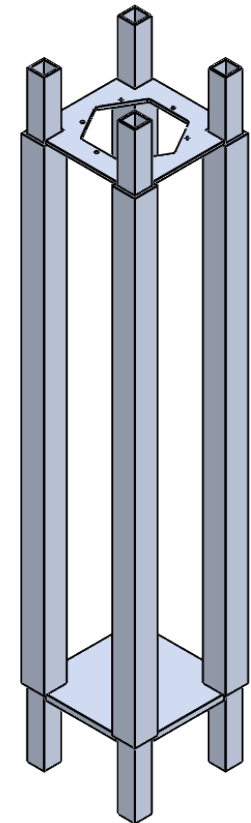
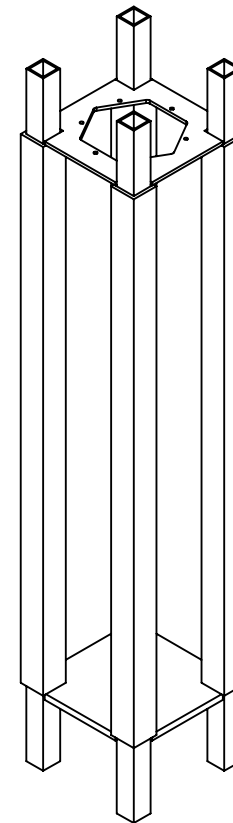
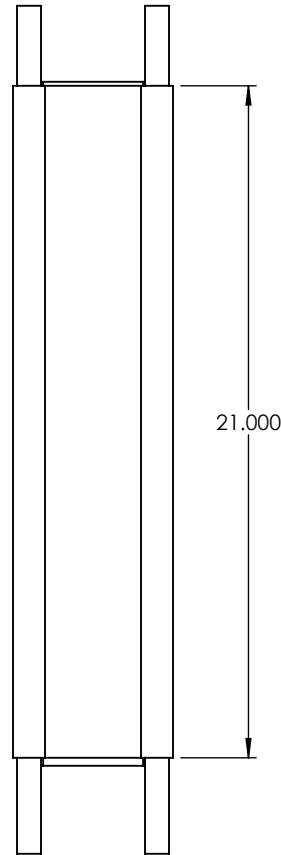
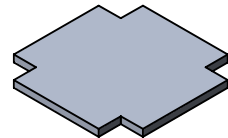
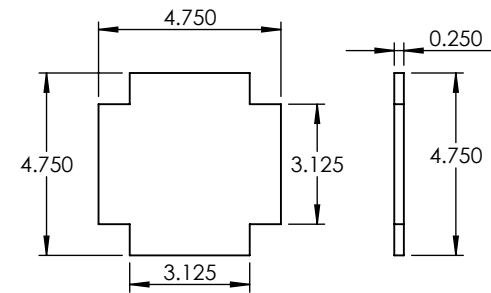
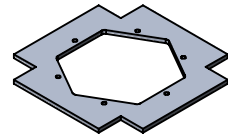
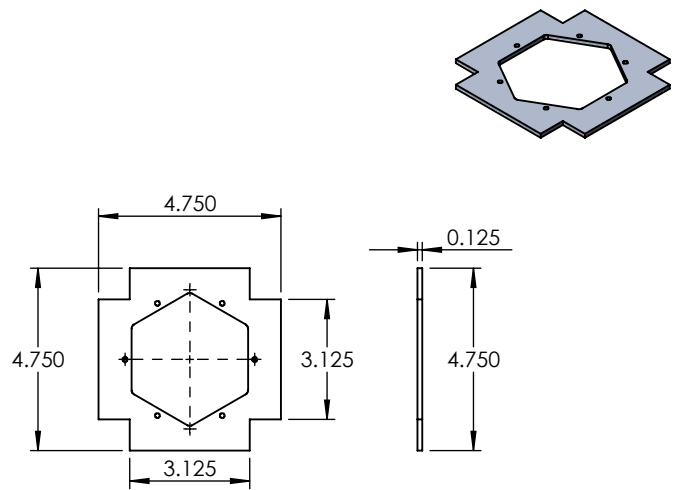

UNLESS OTHERWISE SPECIFIED:

DIMENSIONS ARE IN INCHES
 TOLERANCES:
 FRACTIONAL ±
 ANGULAR: MACH ± BEND ±
 TWO PLACE DECIMAL ±
 THREE PLACE DECIMAL ±

INTERPRET GEOMETRIC
 TOLERANCING PER:

MATERIAL

FINISH

DO NOT SCALE DRAWING

NAME

DATE

DRAWN

CHECKED

ENG APPR.

MFG APPR.

Q.A.

COMMENTS:

ALUMINUM 0.250" PLATE

TITLE:

EC-ARG-B-32-12W

SIZE
A

DWG. NO.

REV

SCALE: 1:6

WEIGHT:

SHEET 8 OF 14

PROPRIETARY AND CONFIDENTIAL
 THE INFORMATION CONTAINED IN THIS
 DRAWING IS THE SOLE PROPERTY OF
 <INSERT COMPANY NAME HERE>. ANY
 REPRODUCTION IN PART OR AS A WHOLE
 WITHOUT THE WRITTEN PERMISSION OF
 <INSERT COMPANY NAME HERE> IS
 PROHIBITED.

NEXT ASSY

USED ON

APPLICATION

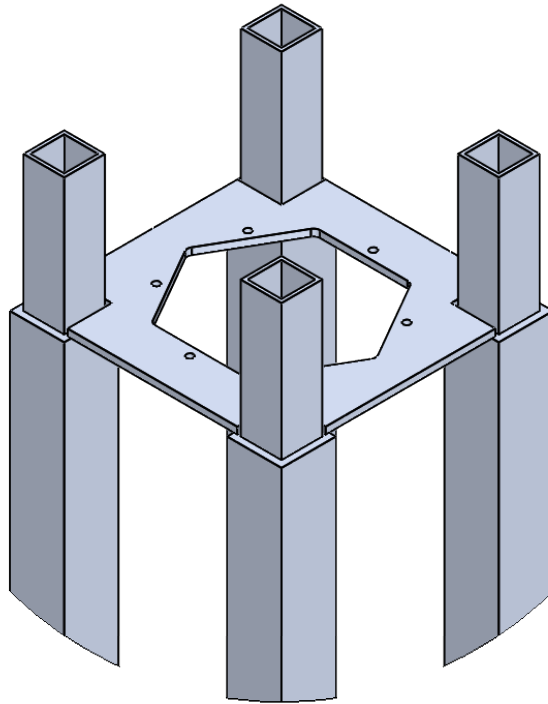
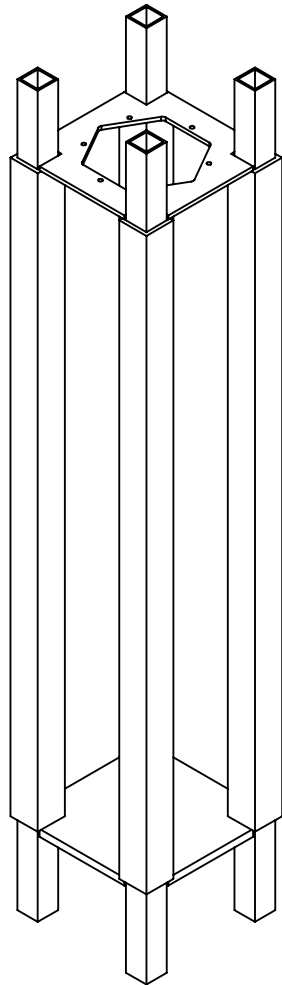

DETAIL A
SCALE 2 : 5

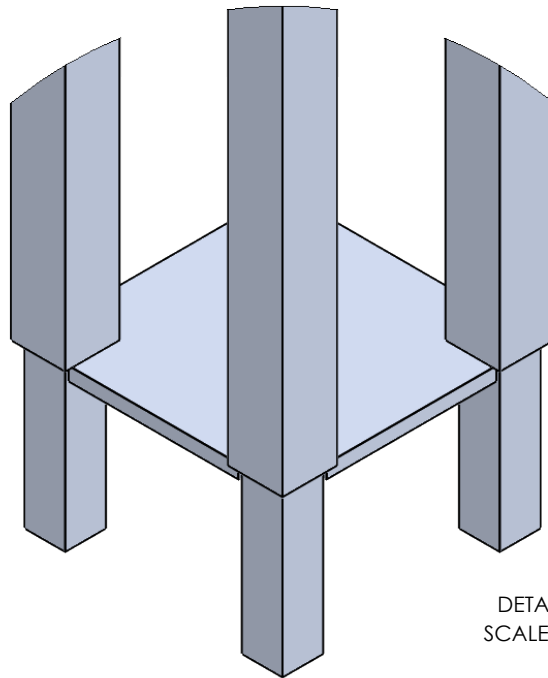

DETAIL B
SCALE 2 : 5

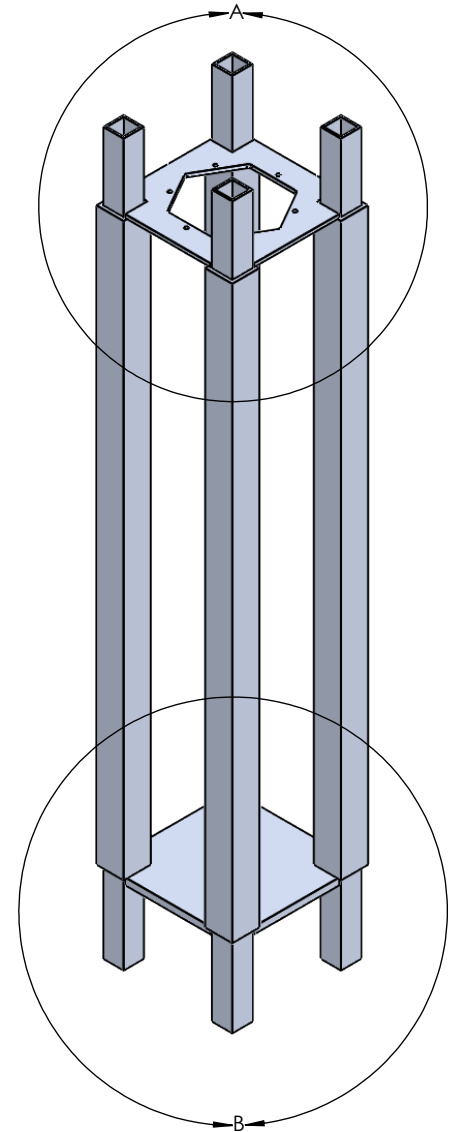

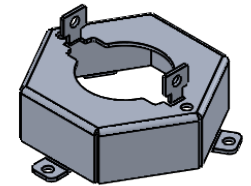
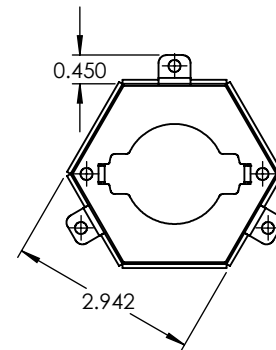
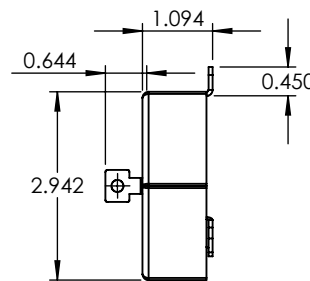
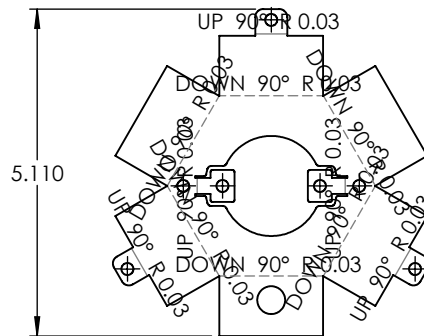
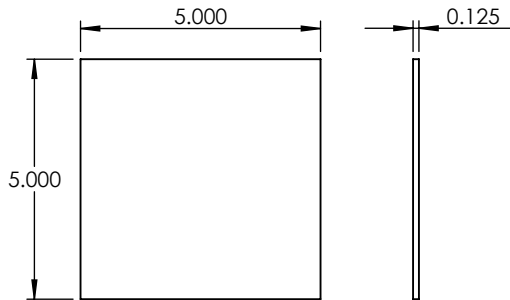
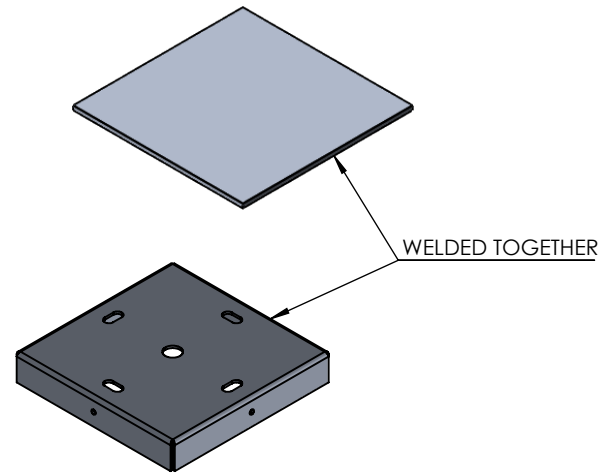
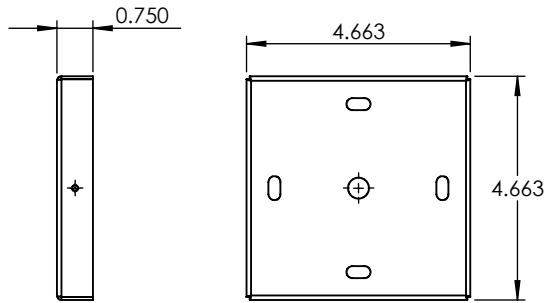
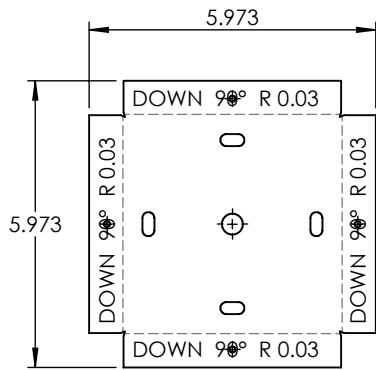

PROPRIETARY AND CONFIDENTIAL
 THE INFORMATION CONTAINED IN THIS DRAWING IS THE SOLE PROPERTY OF <INSERT COMPANY NAME HERE>. ANY REPRODUCTION IN PART OR AS A WHOLE WITHOUT THE WRITTEN PERMISSION OF <INSERT COMPANY NAME HERE> IS PROHIBITED.

		UNLESS OTHERWISE SPECIFIED:		NAME	DATE
		DIMENSIONS ARE IN INCHES TOLERANCES: FRACTIONAL ± ANGULAR: MACH ± BEND ± TWO PLACE DECIMAL ± THREE PLACE DECIMAL ±	DRAWN		
		INTERPRET GEOMETRIC TOLERANCING PER:	CHECKED		
		MATERIAL	ENG APPR.		
		FINISH	MFG APPR.		
NEXT ASSY	USED ON		Q.A.		
APPLICATION	DO NOT SCALE DRAWING		COMMENTS:		

ALUMINUM 0.0635"

TITLE:

EC-ARG-B-32-12W

SIZE	DWG. NO.	REV
A		

SCALE: 1:4 WEIGHT: SHEET 10 OF 14

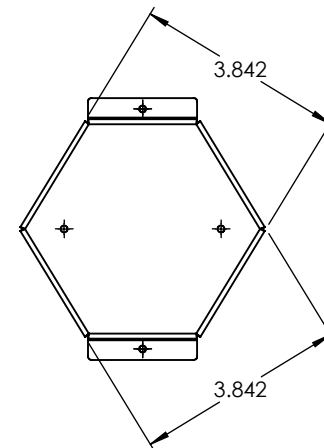
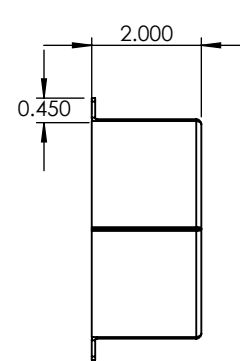
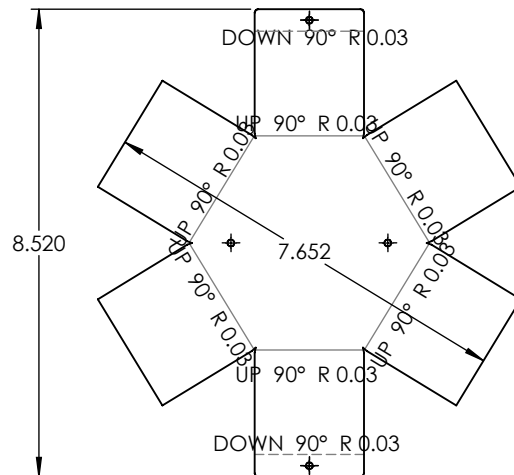
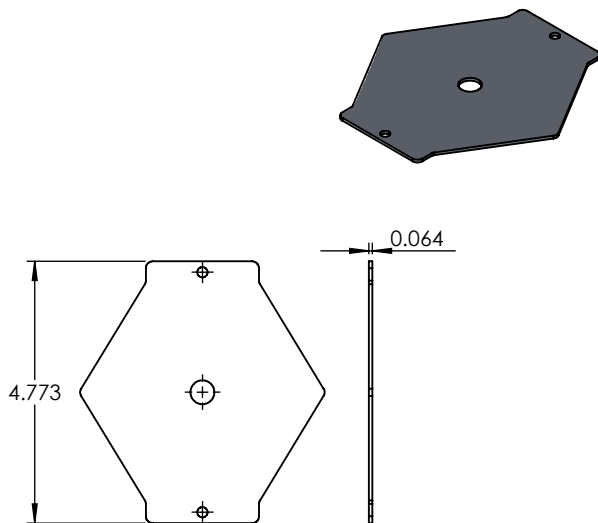
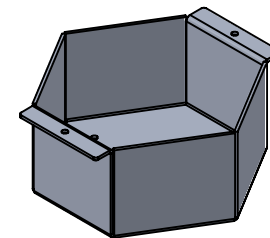
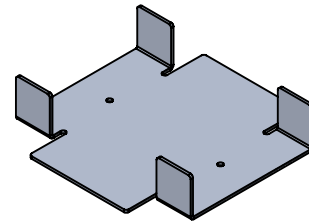
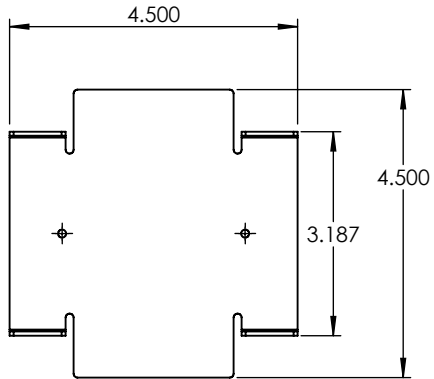
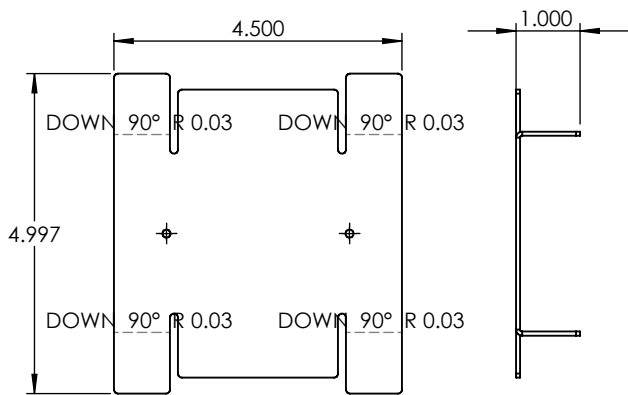

PROPRIETARY AND CONFIDENTIAL
 THE INFORMATION CONTAINED IN THIS DRAWING IS THE SOLE PROPERTY OF <INSERT COMPANY NAME HERE>. ANY REPRODUCTION IN PART OR AS A WHOLE WITHOUT THE WRITTEN PERMISSION OF <INSERT COMPANY NAME HERE> IS PROHIBITED.

NEXT ASSY	USED ON
APPLICATION	

UNLESS OTHERWISE SPECIFIED:	NAME	DATE
DIMENSIONS ARE IN INCHES	DRAWN	
TOLERANCES:	CHECKED	
FRACTIONAL ±	ENG APPR.	
ANGULAR: MACH ± BEND ±	MFG APPR.	
TWO PLACE DECIMAL ±	Q.A.	
THREE PLACE DECIMAL ±	COMMENTS:	
INTERPRET GEOMETRIC TOLERANCING PER:		
MATERIAL		
FINISH		
DO NOT SCALE DRAWING		

ALUMINUM 0.0635"		
TITLE:		
EC-ARG-B-32-12W		
SIZE	DWG. NO.	REV
A		
SCALE: 1:3.5WEIGHT:		SHEET 11 OF 14

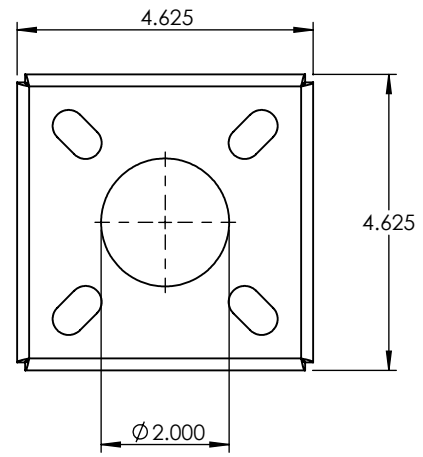
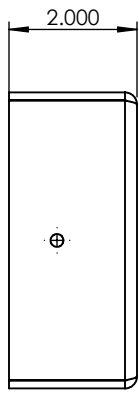
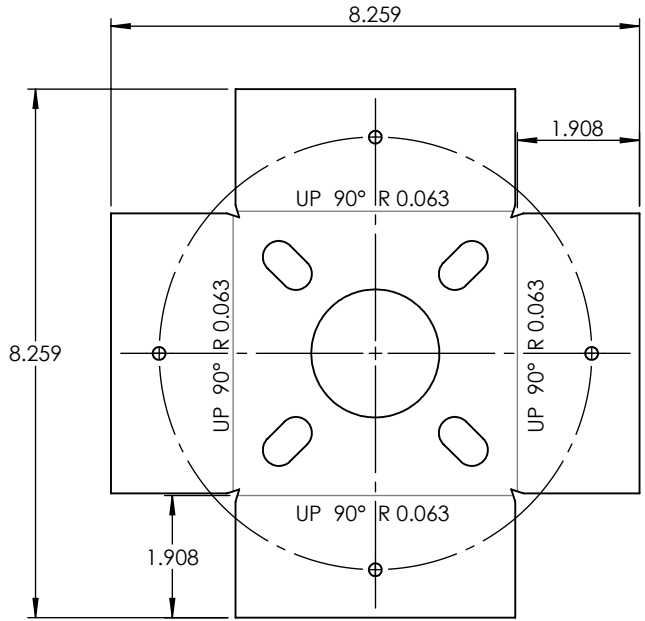
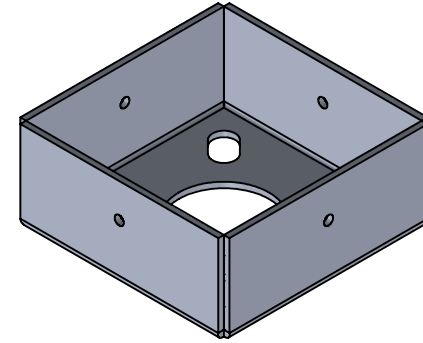

PROPRIETARY AND CONFIDENTIAL
 THE INFORMATION CONTAINED IN THIS DRAWING IS THE SOLE PROPERTY OF <INSERT COMPANY NAME HERE>. ANY REPRODUCTION IN PART OR AS A WHOLE WITHOUT THE WRITTEN PERMISSION OF <INSERT COMPANY NAME HERE> IS PROHIBITED.

		UNLESS OTHERWISE SPECIFIED:	NAME	DATE	ALUMINUM 0.125"	
		DIMENSIONS ARE IN INCHES TOLERANCES: FRACTIONAL ± ANGULAR: MACH ± BEND ± TWO PLACE DECIMAL ± THREE PLACE DECIMAL ±	DRAWN		TITLE:	
		INTERPRET GEOMETRIC TOLERANCING PER:	CHECKED		EC-ARG-B-32-12W	
		MATERIAL	ENG APPR.		SIZE	DWG. NO.
		FINISH	MFG APPR.		A	REV
NEXT ASSY	USED ON		Q.A.		SCALE: 1:3	WEIGHT:
APPLICATION		DO NOT SCALE DRAWING	COMMENTS:			SHEET 12 OF 14

5

4

3

2

1

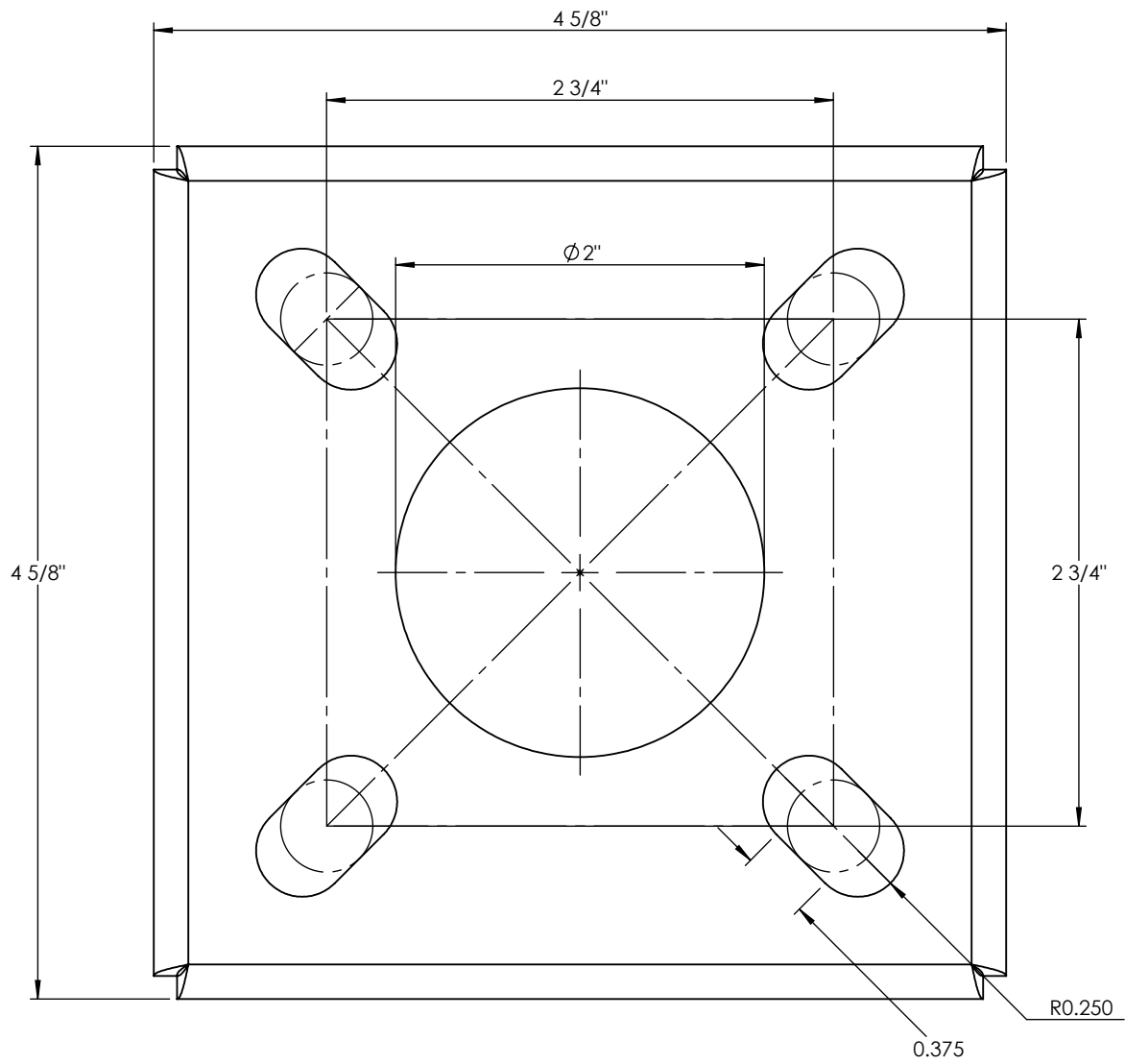

**3/8" X 12" LONG
ANCHOR BOLT SIZE**

ITEM NO.	PART NUMBER	DESCRIPTION	QTY.
1	EC-ARG-B-32-12W-SPUN DOOR	SPUN ALUMINUM 0.0635"	1

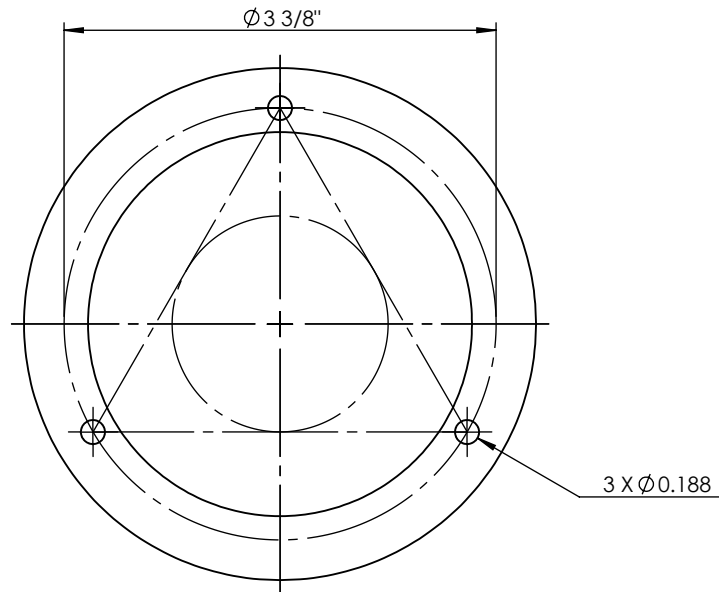
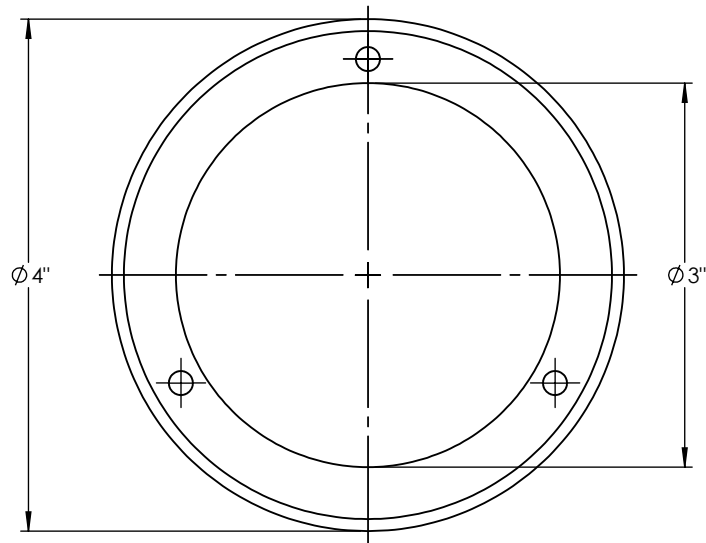
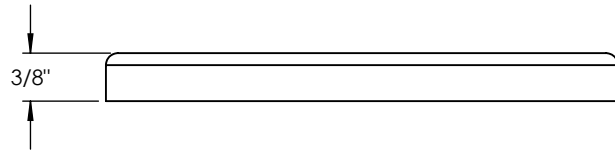
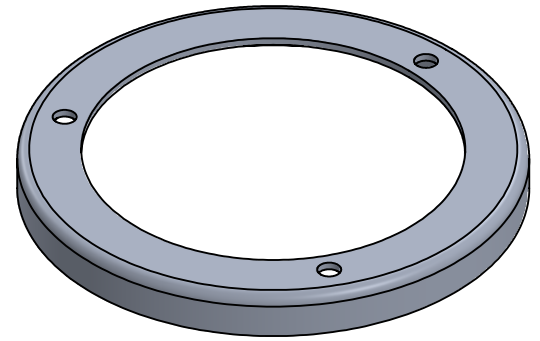

PROPRIETARY AND CONFIDENTIAL
 THE INFORMATION CONTAINED IN THIS DRAWING IS THE SOLE PROPERTY OF <INSERT COMPANY NAME HERE>. ANY REPRODUCTION IN PART OR AS A WHOLE WITHOUT THE WRITTEN PERMISSION OF <INSERT COMPANY NAME HERE> IS PROHIBITED.

		UNLESS OTHERWISE SPECIFIED:		NAME	DATE
		DIMENSIONS ARE IN INCHES	DRAWN		
		TOLERANCES:	CHECKED		
		FRACTIONAL ±	ENG APPR.		
		ANGULAR: MACH ± BEND ±	MFG APPR.		
		TWO PLACE DECIMAL ±	Q.A.		
		THREE PLACE DECIMAL ±	COMMENTS:		
		INTERPRET GEOMETRIC TOLERANCING PER:			
		MATERIAL			
	NEXT ASSY	FINISH			
	USED ON				
	APPLICATION	DO NOT SCALE DRAWING			

SPUN ALUMINUM 0.0635"		
TITLE:		
EC-ARG-B-32-12W		
SIZE	DWG. NO.	REV
A		
SCALE: 1:1.5		WEIGHT:
		SHEET 14 OF 14

5

4

3

2

1