

ITEM NO.	PART NUMBER	DESCRIPTION	QTY.	CUT
1	EC-BOL-2PLR-12W-FRONT PLATE	ALUMINUM 0.125" PLATE	2	
2	EC-BOL-2PLR-12W-SIDES PLATE	ALUMINUM 0.125" PLATE	2	
3	EC-BOL-2PLR-12W-TOP PLATE	ALUMINUM 0.125" PLATE	1	
4	BOL-2PLR-5LED-9-CA-28X10-OPEN SPACE TOP PLATE	ALUMINUM 0.125" PLATE	1	
5	BOL-2PLR-5LED-9-CA-28X10-OPEN SPACE BOTTOM PLATE	ALUMINUM 0.125" PLATE	1	
6	EC-BOL-2PLR-12W-OPEN SPACE SIDE PLATE	ALUMINUM 0.125" PLATE	2	
7	EC-BOL-2PLR-12W-FIREPLATE	ALUMINUM 0.125" PLATE	1	
8	EC-BOL-2PLR-12W-LED BOX BRACKET	ALUMINUM 0.0635"	1	
9	EC-BOL-2PLR-12W-LED BOX	ALUMINUM 0.0635"	1	
10	EC-BOL-2PLR-12W-DOOR	ALUMINUM 0.0635"	1	
11	EC-BOL-2PLR-12W-DRIVER BOX	ALUMINUM 0.0635"	1	
12	EC-BOL-2PLR-12W-DRIVER CAP	ALUMINUM 0.0635"	1	
13	EC-BOL-2PLR-12W-SOCKET BRACKET	ALUMINUM 0.0635"	1	
14	EC-BOL-2PLR-12W-COVER TAB	25 GAUGE	4	
15	EC-BOL-2PLR-12W-ACRYLIC	ACRYLIC	1	
16	55MM HEXAGON HEAT SINK	HEAT SINK	1	
17	DS-15W-350C1542010-3001	DRIVER	1	
18	AltAILED_PCN_D1500_110B-10 WATT	LED	1	

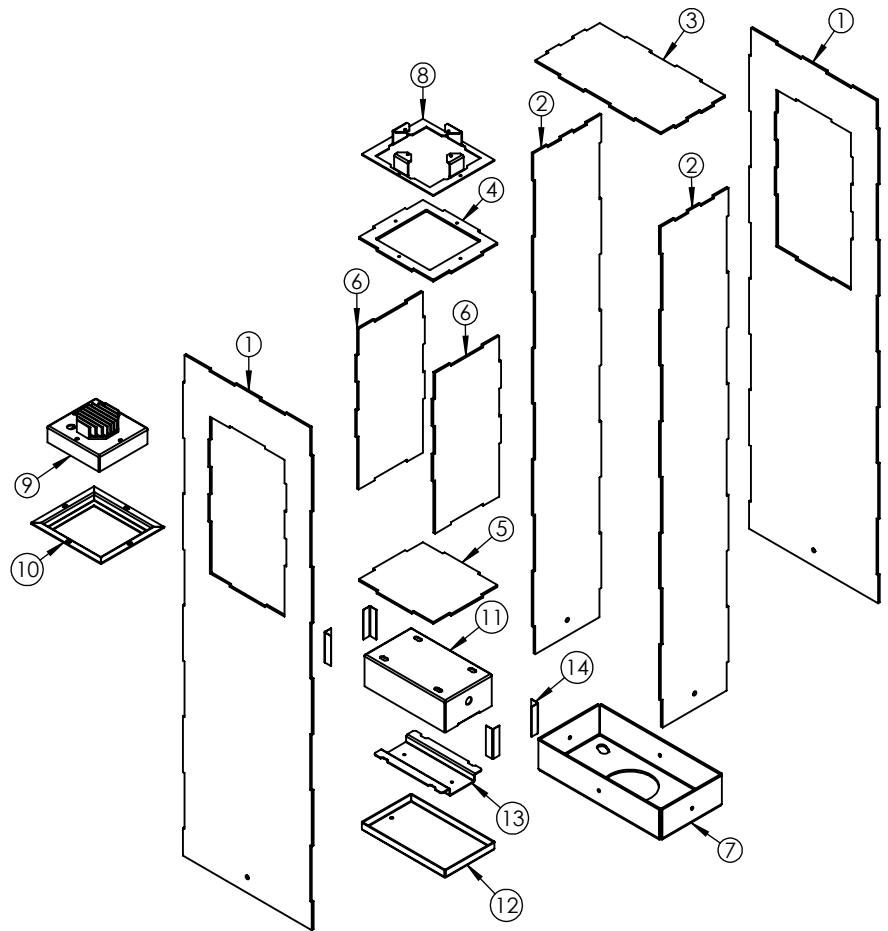
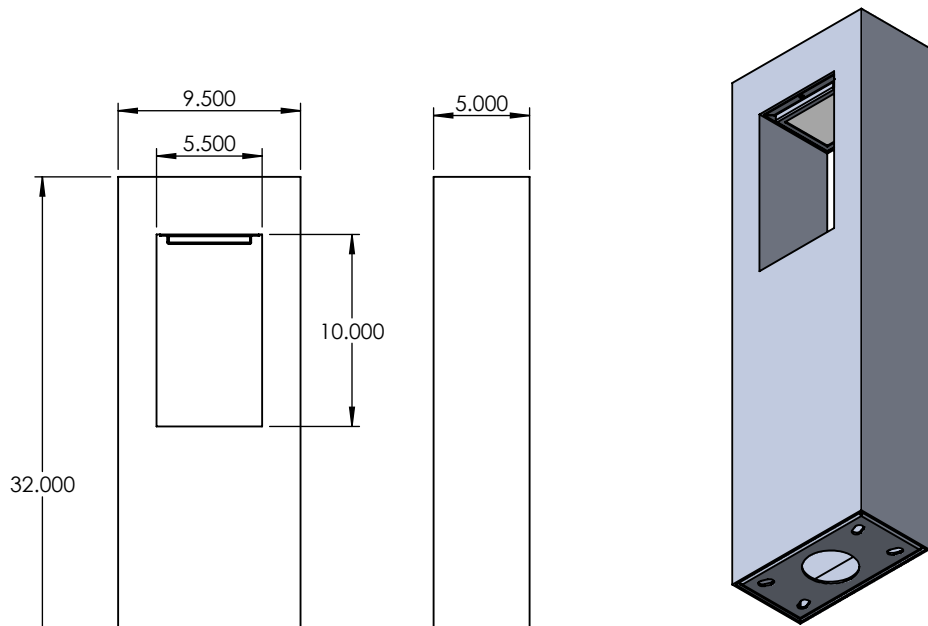

ALL BEND RADIUS .030"

APPLICATION

DO NOT SCALE DRAWING

UNLESS OTHERWISE SPECIFIED:

DIMENSIONS ARE IN INCHES
TOLERANCES:
FRACTIONAL ± .003
ANGULAR: MACH ±.01 BEND ±
TWO PLACE DECIMAL ±
THREE PLACE DECIMAL ±.001

INTERPRET GEOMETRIC
TOLERANCING PER:

MATERIAL

FINISH

NAME

DATE

DRAWN

CHECKED

ENG APPR.

MFG APPR.

Q.A.

COMMENTS:

TITLE:

EC-BOL-2PLR-12W

SIZE
A

DWG. NO.

REV

SCALE: 1:10 WEIGHT:

SHEET 1 OF 10

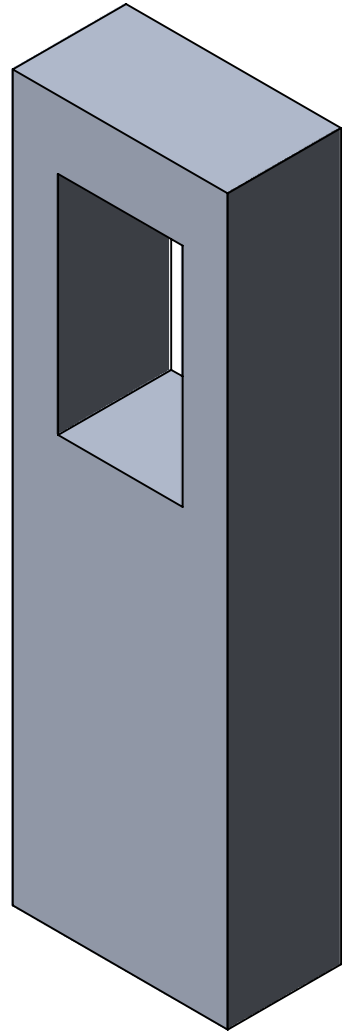
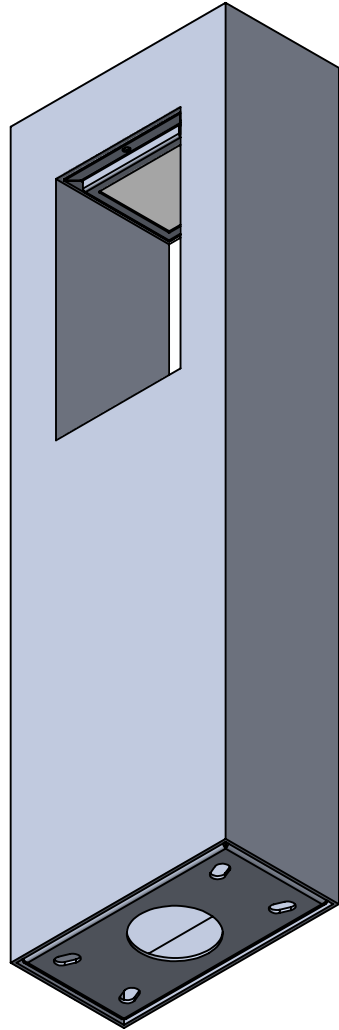
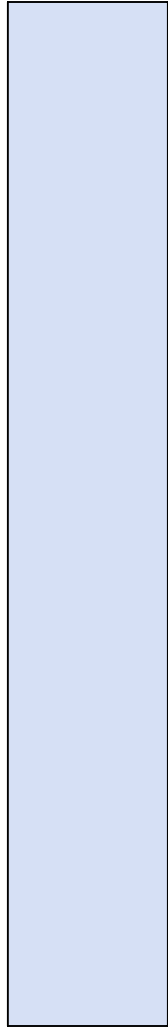
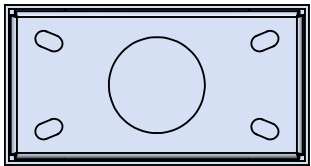
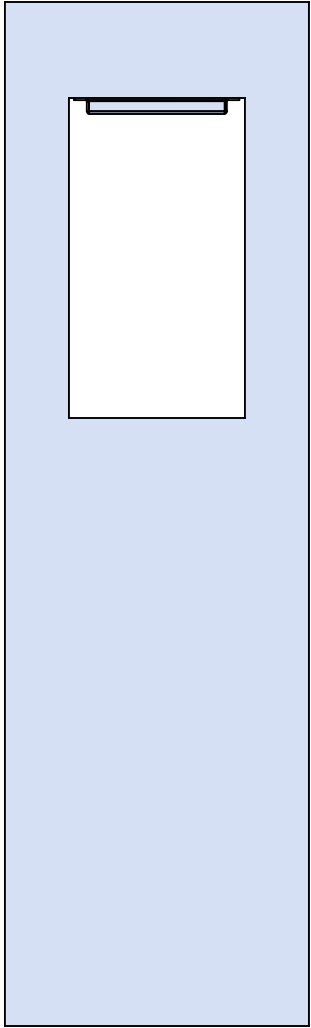

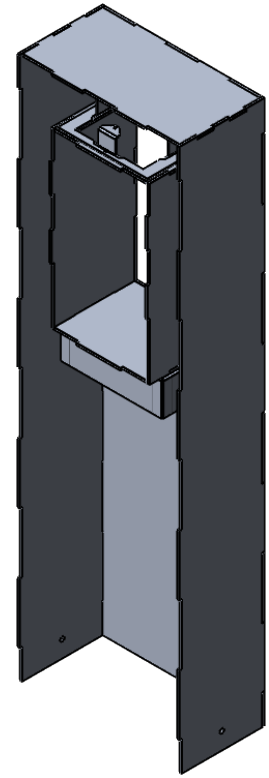
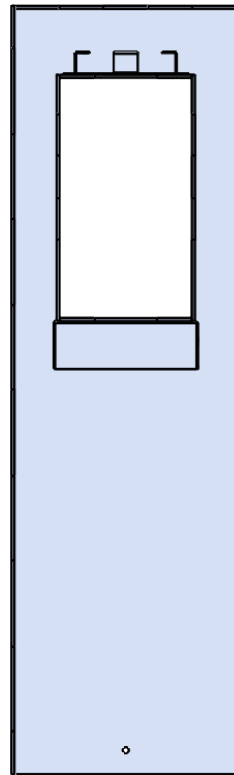
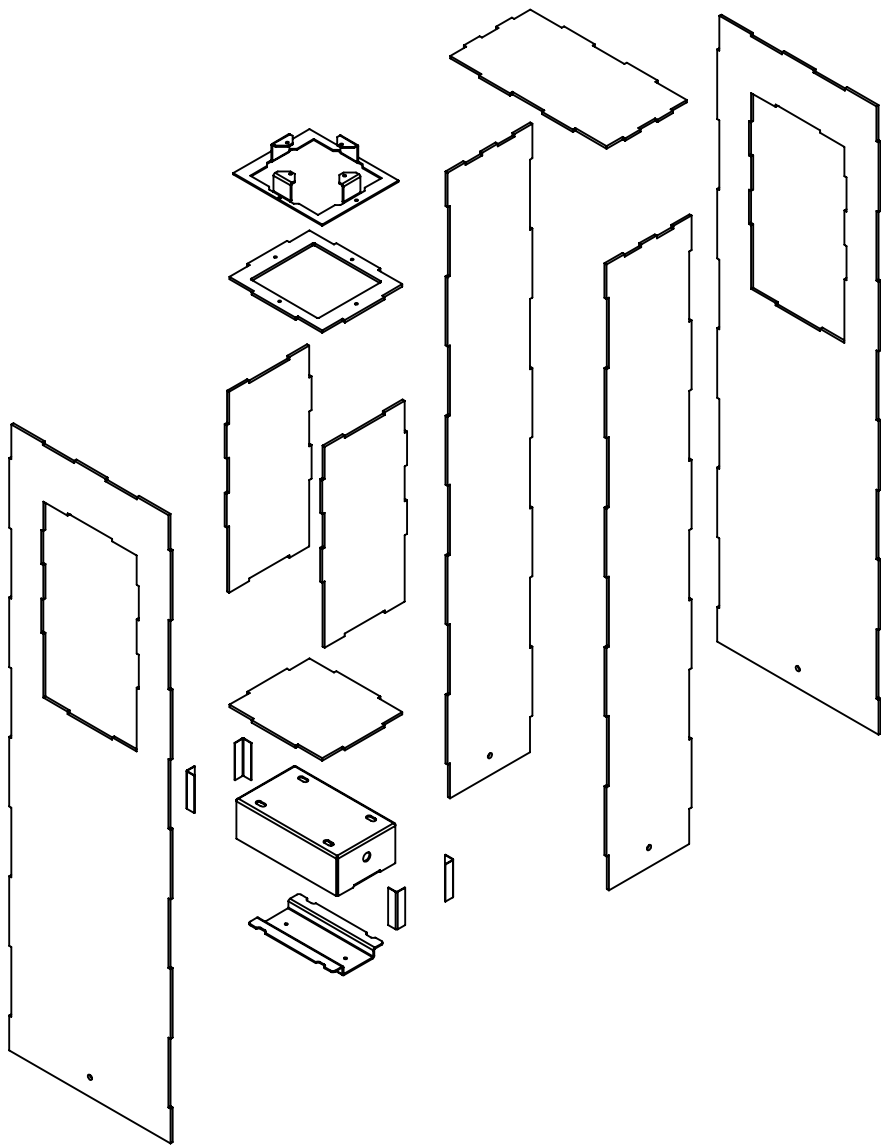

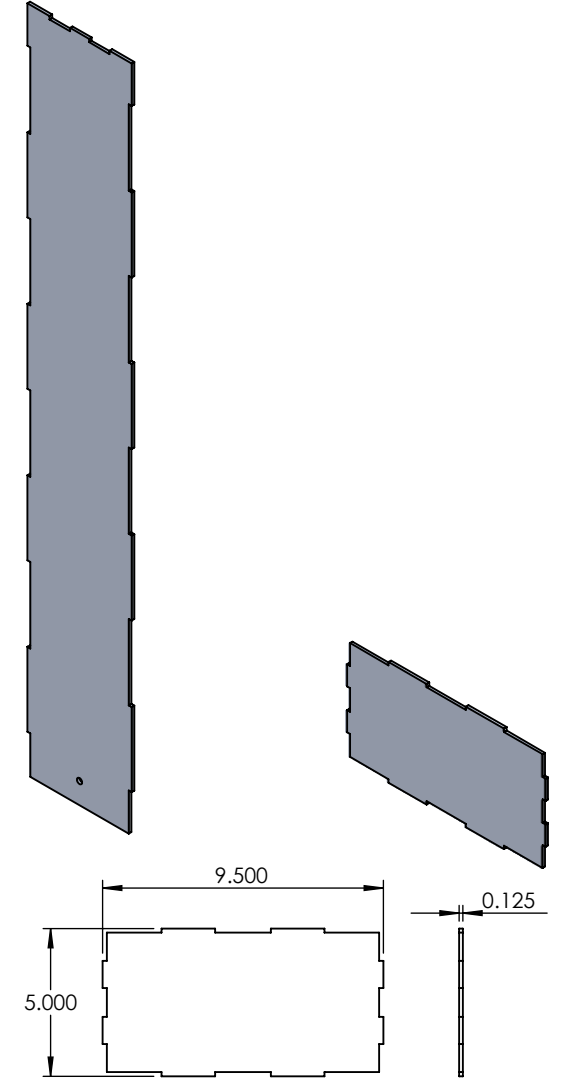
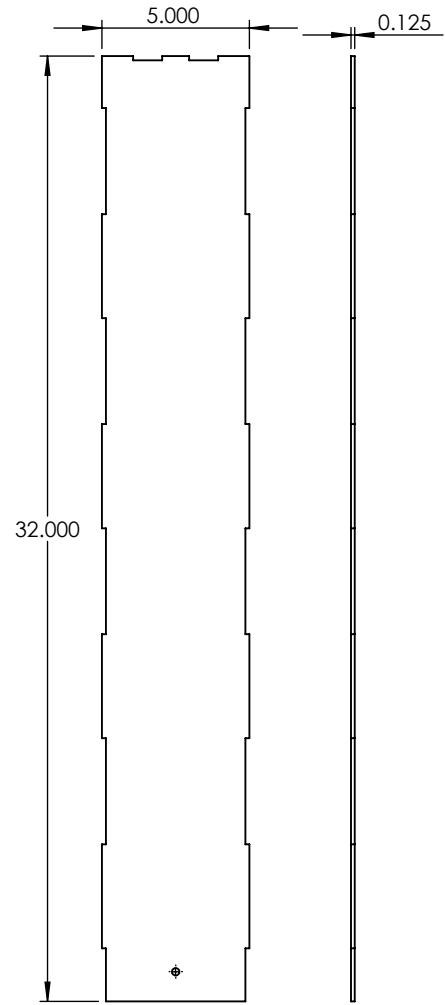
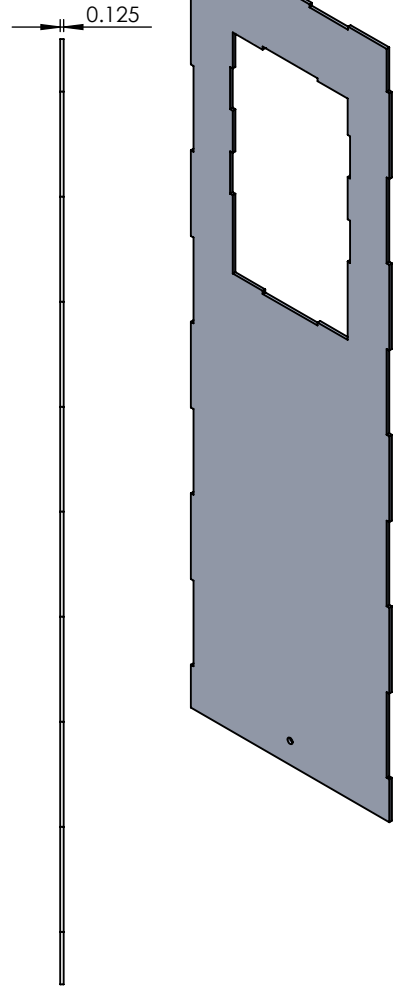
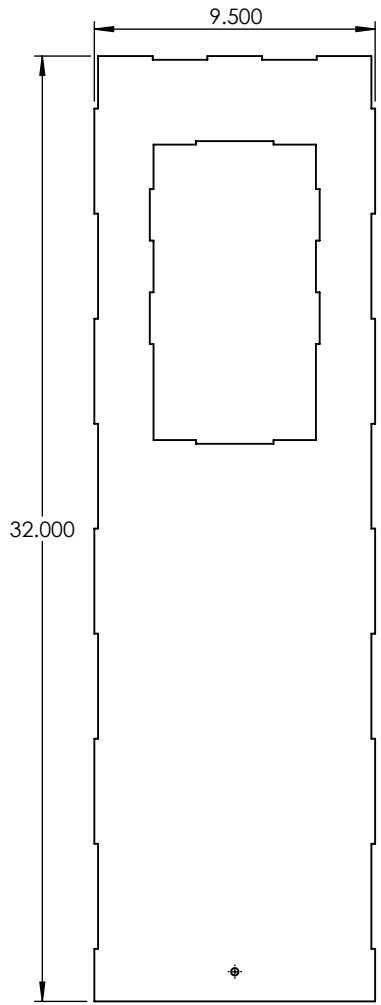

PROPRIETARY AND CONFIDENTIAL
 THE INFORMATION CONTAINED IN THIS DRAWING IS THE SOLE PROPERTY OF <INSERT COMPANY NAME HERE>. ANY REPRODUCTION IN PART OR AS A WHOLE WITHOUT THE WRITTEN PERMISSION OF <INSERT COMPANY NAME HERE> IS PROHIBITED.

		UNLESS OTHERWISE SPECIFIED:		NAME	DATE
		DIMENSIONS ARE IN INCHES	DRAWN		
		TOLERANCES:	CHECKED		
		FRACTIONAL ±	ENG APPR.		
		ANGULAR: MACH ± BEND ±	MFG APPR.		
		TWO PLACE DECIMAL ±	Q.A.		
		THREE PLACE DECIMAL ±	COMMENTS:		
		INTERPRET GEOMETRIC TOLERANCING PER:			
		MATERIAL			
		FINISH			
NEXT ASSY	USED ON				
APPLICATION		DO NOT SCALE DRAWING			

ALUMINUM 0.125" PLATE		
TITLE:		
EC-BOL-2PLR-12W		
SIZE	DWG. NO.	REV
A		
SCALE: 1:6.5WEIGHT:		SHEET 4 OF 10

5

4

3

2

1

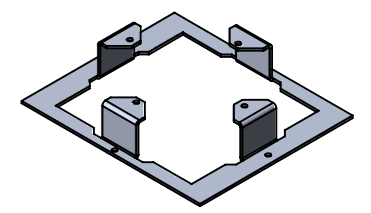
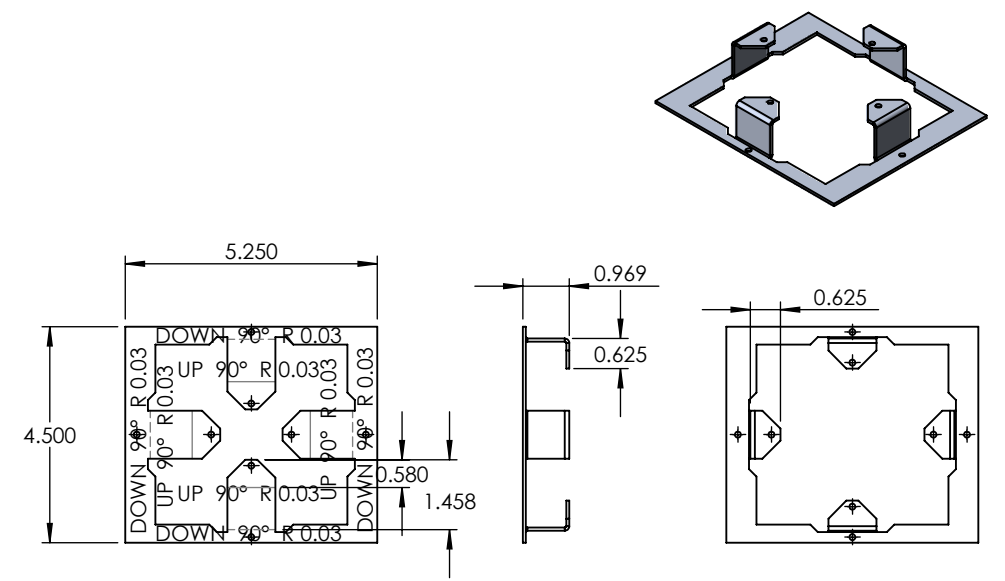
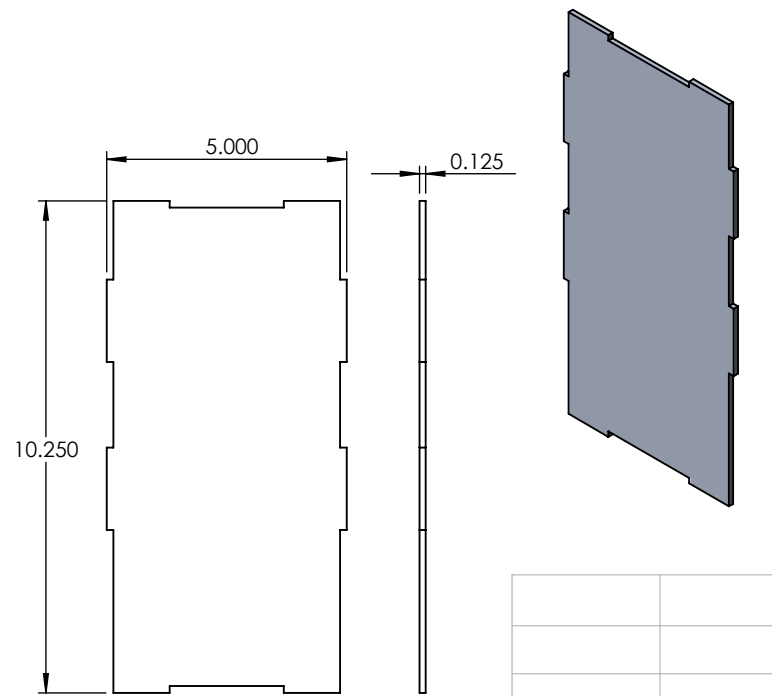
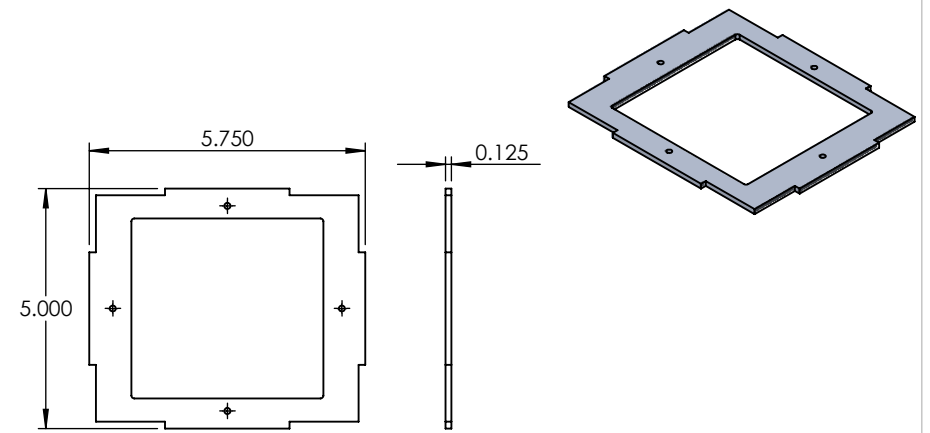
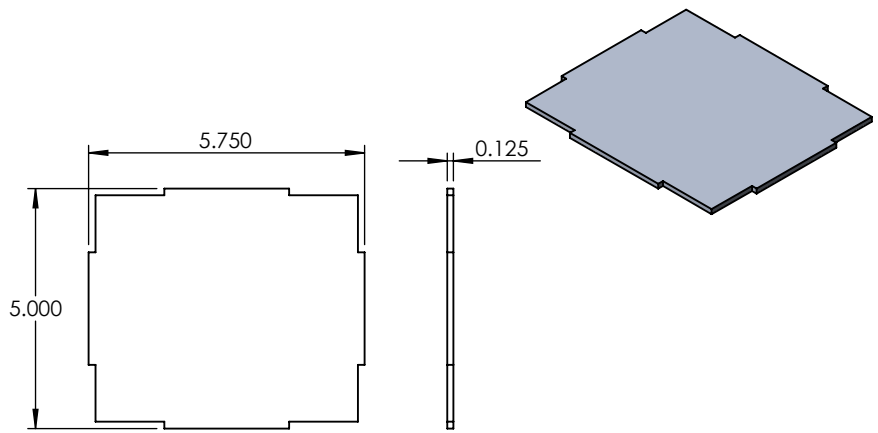

PROPRIETARY AND CONFIDENTIAL
 THE INFORMATION CONTAINED IN THIS DRAWING IS THE SOLE PROPERTY OF <INSERT COMPANY NAME HERE>. ANY REPRODUCTION IN PART OR AS A WHOLE WITHOUT THE WRITTEN PERMISSION OF <INSERT COMPANY NAME HERE> IS PROHIBITED.

		UNLESS OTHERWISE SPECIFIED:	NAME	DATE
		DIMENSIONS ARE IN INCHES	DRAWN	
		TOLERANCES:	CHECKED	
		FRACTIONAL ±	ENG APPR.	
		ANGULAR: MACH ± BEND ±	MFG APPR.	
		TWO PLACE DECIMAL ±	Q.A.	
		THREE PLACE DECIMAL ±	COMMENTS:	
		INTERPRET GEOMETRIC TOLERANCING PER:		
		MATERIAL		
		FINISH		
NEXT ASSY	USED ON			
APPLICATION		DO NOT SCALE DRAWING		

ALUMINUM 0.125" PLATE		
TITLE:		
EC-BOL-2PLR-12W		
SIZE	DWG. NO.	REV
A		
SCALE: 1:4	WEIGHT:	SHEET 5 OF 10

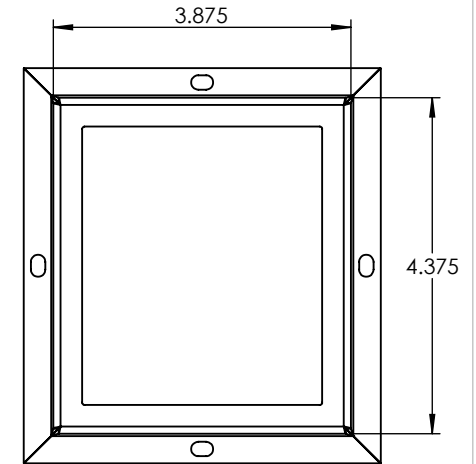
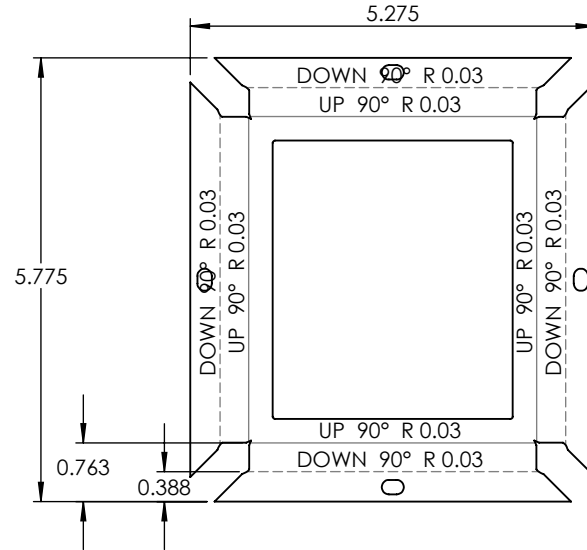
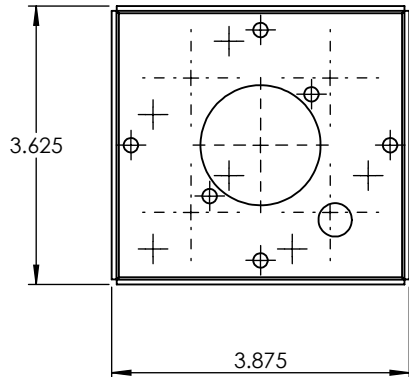
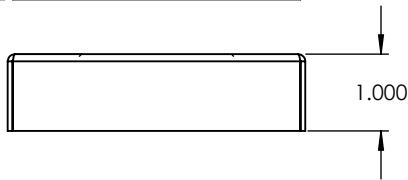
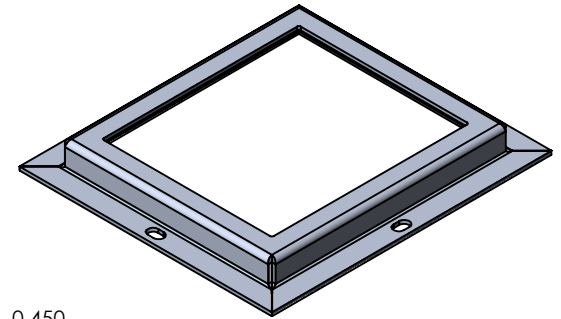
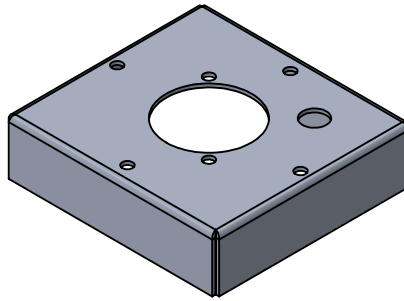
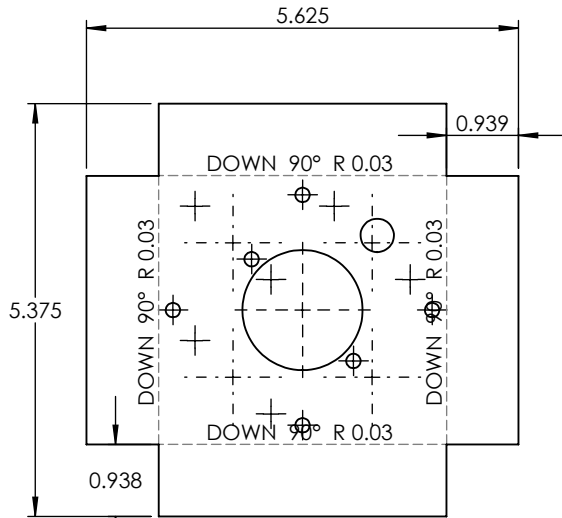

PROPRIETARY AND CONFIDENTIAL
 THE INFORMATION CONTAINED IN THIS DRAWING IS THE SOLE PROPERTY OF <INSERT COMPANY NAME HERE>. ANY REPRODUCTION IN PART OR AS A WHOLE WITHOUT THE WRITTEN PERMISSION OF <INSERT COMPANY NAME HERE> IS PROHIBITED.

		UNLESS OTHERWISE SPECIFIED:	NAME	DATE	ALUMINUM 0.0635"	
		DIMENSIONS ARE IN INCHES	DRAWN		TITLE:	
		TOLERANCES:	CHECKED		EC-BOL-2PLR-12W	
		FRACTIONAL ±	ENG APPR.		SIZE	DWG. NO.
		ANGULAR: MACH ± BEND ±	MFG APPR.		A	REV
		TWO PLACE DECIMAL ±	Q.A.		SCALE: 1:2.5WEIGHT:	
		THREE PLACE DECIMAL ±	COMMENTS:		SHEET 6 OF 10	
NEXT ASSY	USED ON	INTERPRET GEOMETRIC TOLERANCING PER:				
APPLICATION		MATERIAL				
		FINISH				
		DO NOT SCALE DRAWING				

5

4

3

2

1

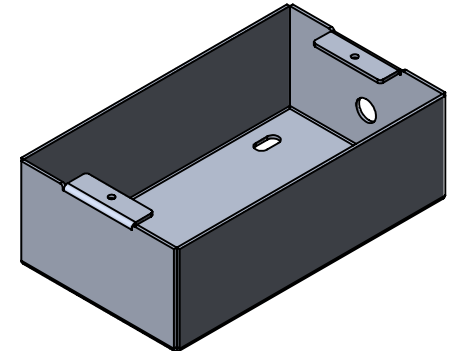
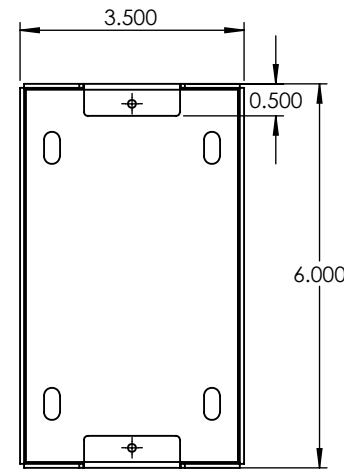
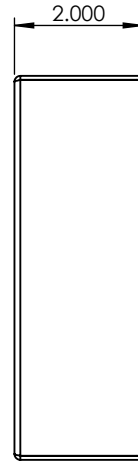
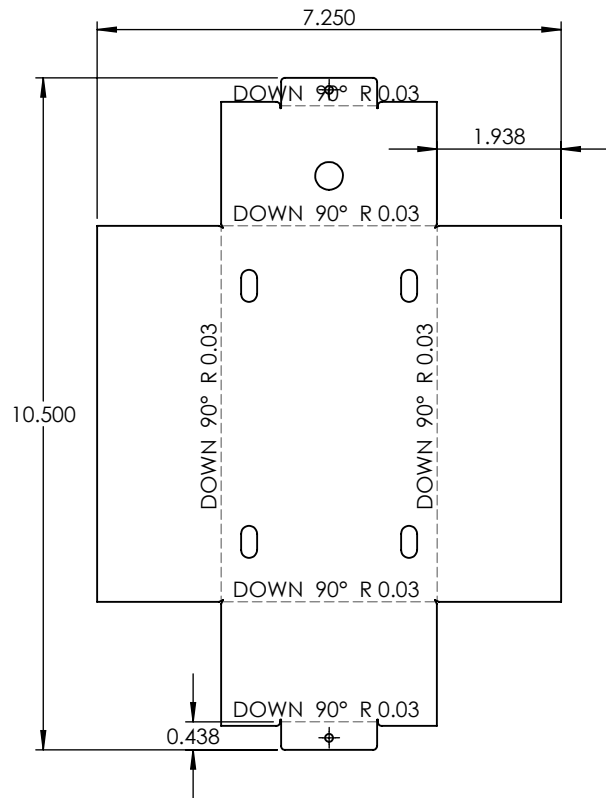
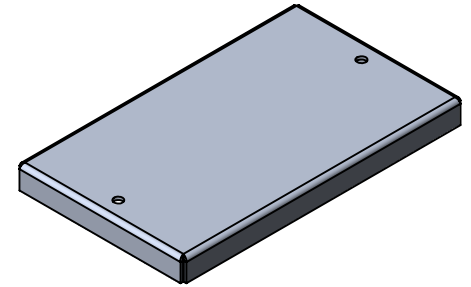
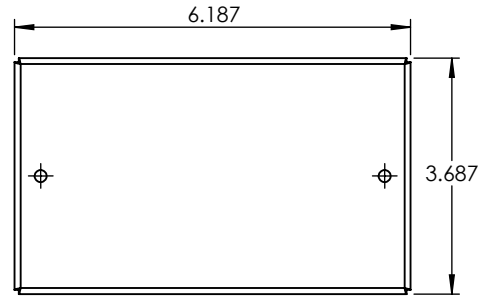
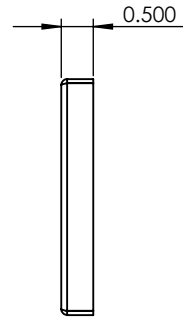
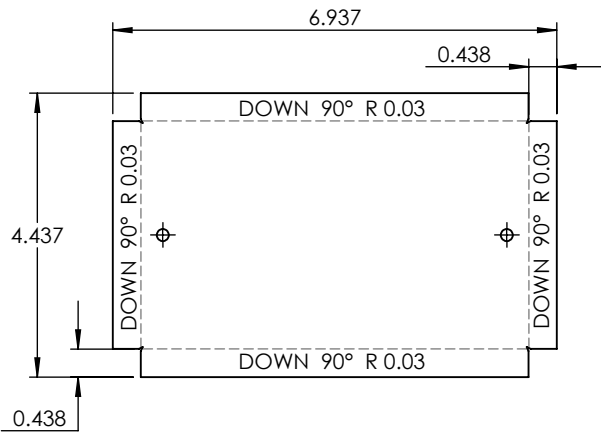

UNLESS OTHERWISE SPECIFIED:

DIMENSIONS ARE IN INCHES
 TOLERANCES:
 FRACTIONAL ±
 ANGULAR: MACH ± BEND ±
 TWO PLACE DECIMAL ±
 THREE PLACE DECIMAL ±

INTERPRET GEOMETRIC
 TOLERANCING PER:

MATERIAL

FINISH

DO NOT SCALE DRAWING

NAME

DATE

DRAWN

CHECKED

ENG APPR.

MFG APPR.

Q.A.

COMMENTS:

ALUMINUM 0.0635"

TITLE:

EC-BOL-2PLR-12W

SIZE
A

DWG. NO.

REV

SCALE: 1:3

WEIGHT:

SHEET 7 OF 10

PROPRIETARY AND CONFIDENTIAL
 THE INFORMATION CONTAINED IN THIS
 DRAWING IS THE SOLE PROPERTY OF
 <INSERT COMPANY NAME HERE>. ANY
 REPRODUCTION IN PART OR AS A WHOLE
 WITHOUT THE WRITTEN PERMISSION OF
 <INSERT COMPANY NAME HERE> IS
 PROHIBITED.

NEXT ASSY

USED ON

APPLICATION

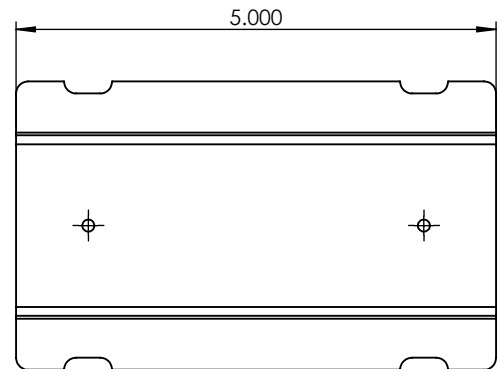
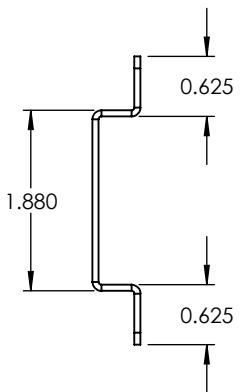
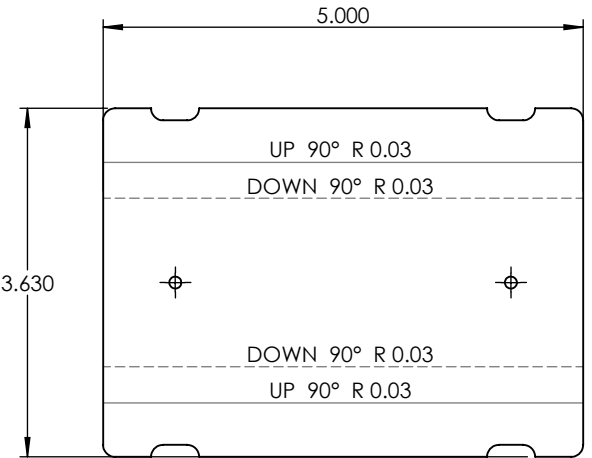
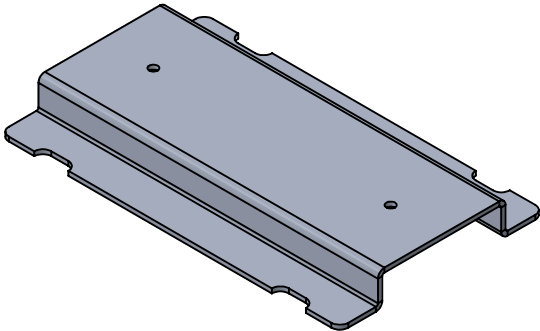

PROPRIETARY AND CONFIDENTIAL
 THE INFORMATION CONTAINED IN THIS DRAWING IS THE SOLE PROPERTY OF <INSERT COMPANY NAME HERE>. ANY REPRODUCTION IN PART OR AS A WHOLE WITHOUT THE WRITTEN PERMISSION OF <INSERT COMPANY NAME HERE> IS PROHIBITED.

NEXT ASSY	USED ON
APPLICATION	

UNLESS OTHERWISE SPECIFIED:
 DIMENSIONS ARE IN INCHES
 TOLERANCES:
 FRACTIONAL ±
 ANGULAR: MACH ± BEND ±
 TWO PLACE DECIMAL ±
 THREE PLACE DECIMAL ±

INTERPRET GEOMETRIC TOLERANCING PER:
 MATERIAL
 FINISH

DO NOT SCALE DRAWING

	NAME	DATE
DRAWN		
CHECKED		
ENG APPR.		
MFG APPR.		
Q.A.		
COMMENTS:		

ALUMINUM 0.0635"		
TITLE: EC-BOL-2PLR-12W		
SIZE A	DWG. NO.	REV
SCALE: 1:2	WEIGHT:	SHEET 8 OF 10

5

4

3

2

1

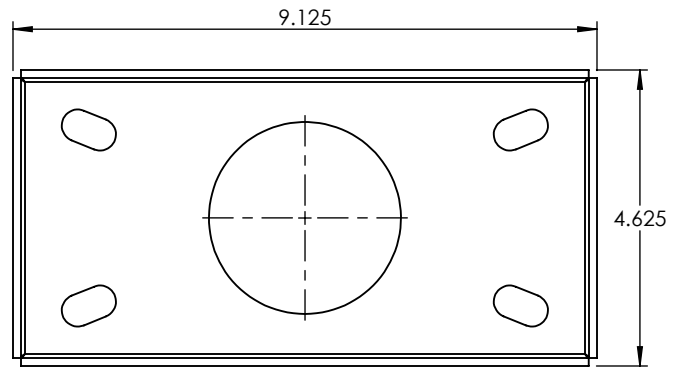
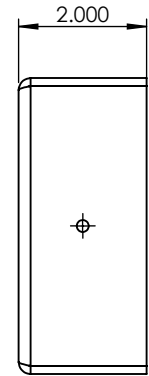
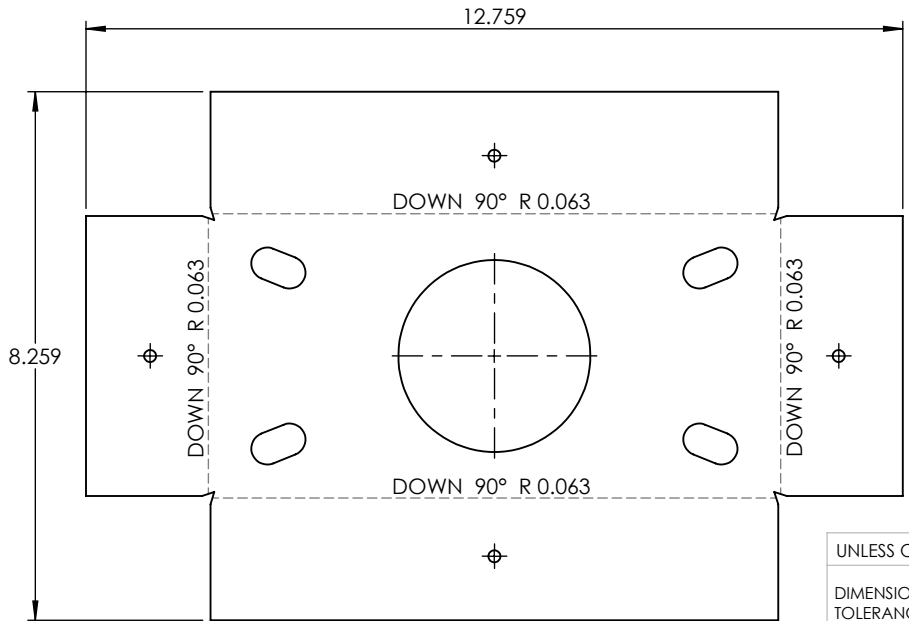
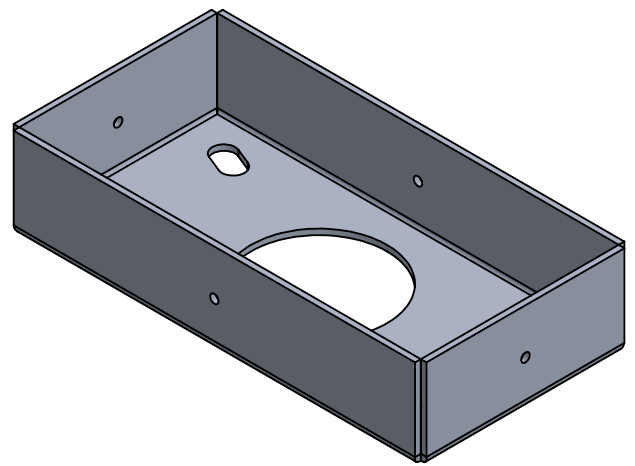
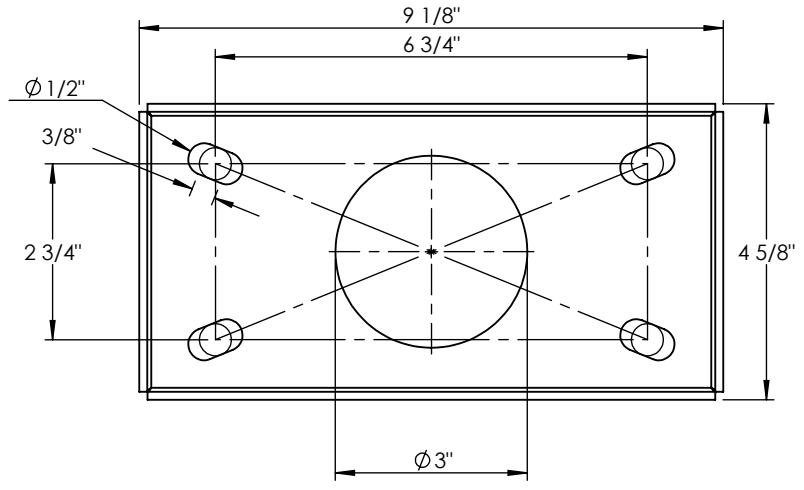

UNLESS OTHERWISE SPECIFIED:

DIMENSIONS ARE IN INCHES
 TOLERANCES:
 FRACTIONAL ±
 ANGULAR: MACH ± BEND ±
 TWO PLACE DECIMAL ±
 THREE PLACE DECIMAL ±

INTERPRET GEOMETRIC
 TOLERANCING PER:

MATERIAL

FINISH

DO NOT SCALE DRAWING

	NAME	DATE
DRAWN		
CHECKED		
ENG APPR.		
MFG APPR.		
Q.A.		

COMMENTS:

ALUMINUM 0.125" PLATE

TITLE:

EC-BOL-2PLR-12W

SIZE	DWG. NO.	REV
A		
SCALE: 1:3	WEIGHT:	SHEET 9 OF 10

PROPRIETARY AND CONFIDENTIAL
 THE INFORMATION CONTAINED IN THIS
 DRAWING IS THE SOLE PROPERTY OF
 <INSERT COMPANY NAME HERE>. ANY
 REPRODUCTION IN PART OR AS A WHOLE
 WITHOUT THE WRITTEN PERMISSION OF
 <INSERT COMPANY NAME HERE> IS
 PROHIBITED.

NEXT ASSY	USED ON	APPLICATION

5

4

3

2

1

