

ITEM NO.	PART NUMBER	DESCRIPTION	QTY.	CUT
1	EC-BOL-2PLR-20W-FRONT PLATE	ALUMINUM 0.125" PLATE	2	
2	EC-BOL-2PLR-20W-SIDES PLATE	ALUMINUM 0.125" PLATE	2	
3	EC-BOL-2PLR-20W-TOP PLATE	ALUMINUM 0.125" PLATE	1	
4	BOL-2PLR-5LED-9-CA-28X10-OPEN SPACE TOP PLATE	ALUMINUM 0.125" PLATE	1	
5	BOL-2PLR-5LED-9-CA-28X10-OPEN SPACE BOTTOM PLATE	ALUMINUM 0.125" PLATE	1	
6	EC-BOL-2PLR-20W-OPEN SPACE SIDE PLATE	ALUMINUM 0.125" PLATE	2	
7	EC-BOL-2PLR-20W-FIREPLATE	ALUMINUM 0.125" PLATE	1	
8	EC-BOL-2PLR-20W-LED BOX BRACKET	ALUMINUM 0.0635"	1	
9	EC-BOL-2PLR-20W-LED BOX	ALUMINUM 0.0635"	1	
10	EC-BOL-2PLR-20W-DOOR	ALUMINUM 0.0635"	1	
11	EC-BOL-2PLR-20W-DRIVER BOX	ALUMINUM 0.0635"	1	
12	EC-BOL-2PLR-20W-DRIVER CAP	ALUMINUM 0.0635"	1	
13	EC-BOL-2PLR-20W-SOCKET BRACKET	ALUMINUM 0.0635"	1	
14	EC-BOL-2PLR-20W-COVER TAB	25 GAUGE	4	
15	EC-BOL-2PLR-20W-ACRYLIC	ACRYLIC	1	
16	43 MM HEAT SINK	HEAT SINK	4	
17	ESPEN VEL29070MVH-1	DRIVER	1	
18	AltGLED_PCN_D1000_105B	LED	4	

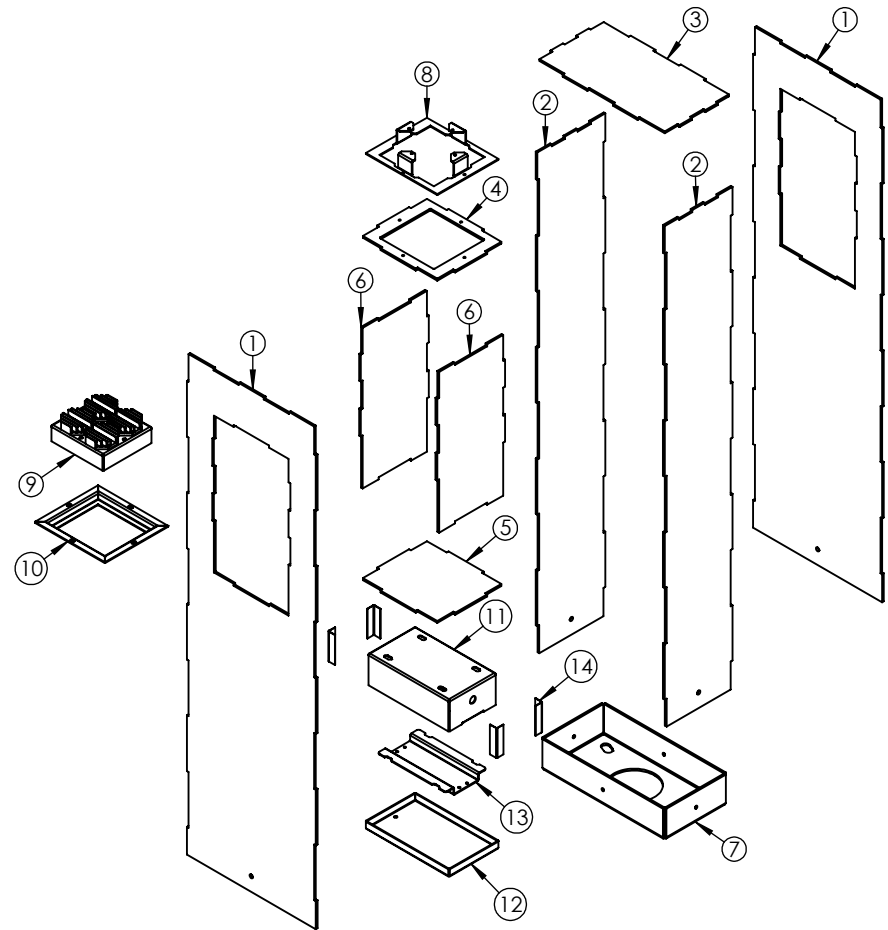
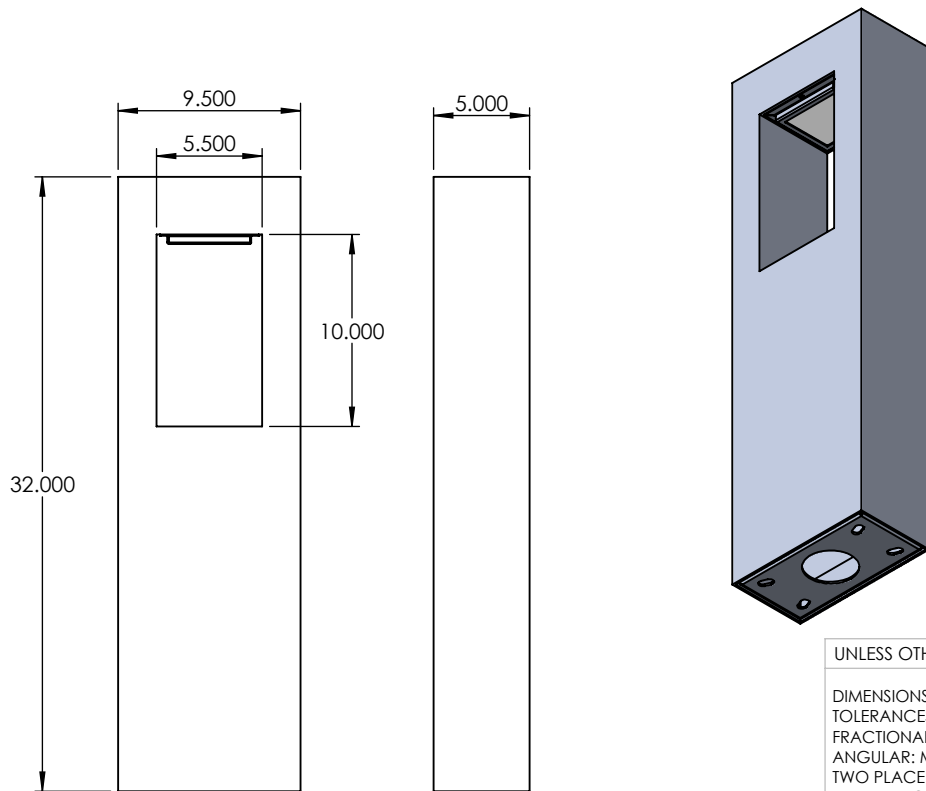

ALL BEND RADIUS .030"

APPLICATION

DO NOT SCALE DRAWING

UNLESS OTHERWISE SPECIFIED:

DIMENSIONS ARE IN INCHES
TOLERANCES:
FRACTIONAL ± .003
ANGULAR: MACH ± .01 BEND ±
TWO PLACE DECIMAL ±
THREE PLACE DECIMAL ±.001

INTERPRET GEOMETRIC
TOLERANCING PER:

MATERIAL

FINISH

NAME

DATE

DRAWN

CHECKED

ENG APPR.

MFG APPR.

Q.A.

COMMENTS:

TITLE:

EC-BOL-2PLR-20W

SIZE
A

DWG. NO.

REV

SCALE: 1:10 WEIGHT:

SHEET 1 OF 10

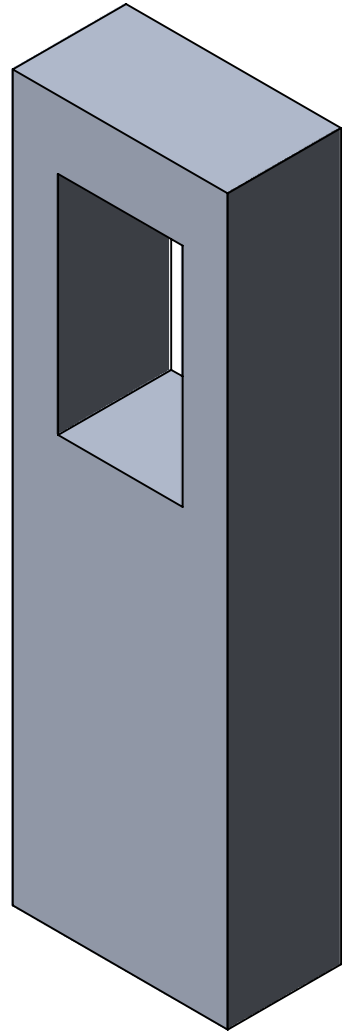
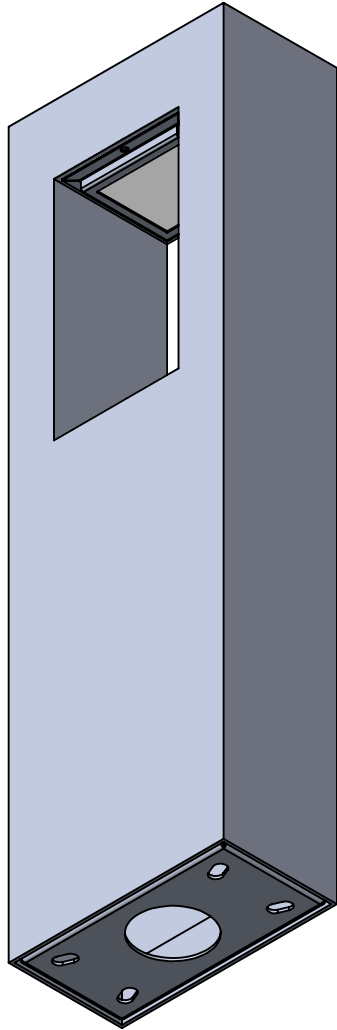
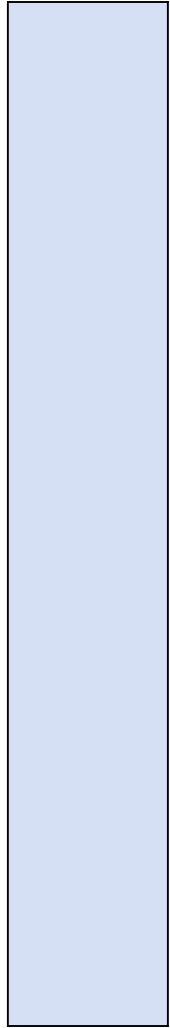
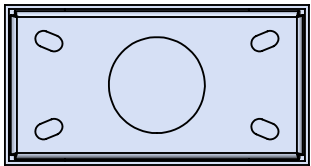
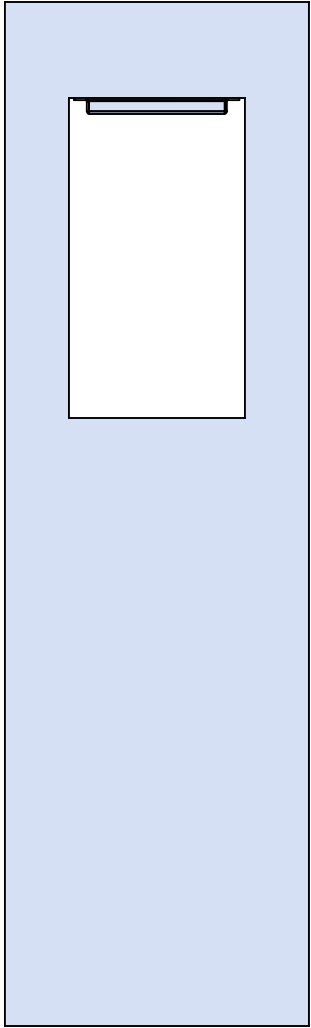

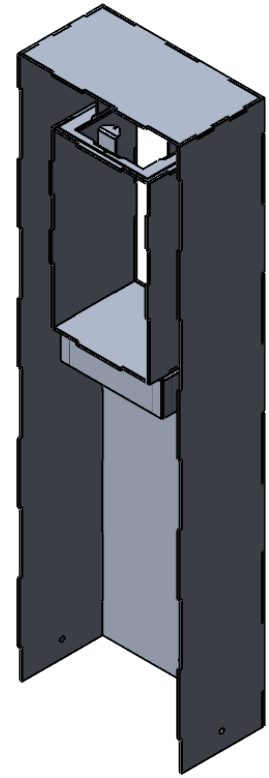
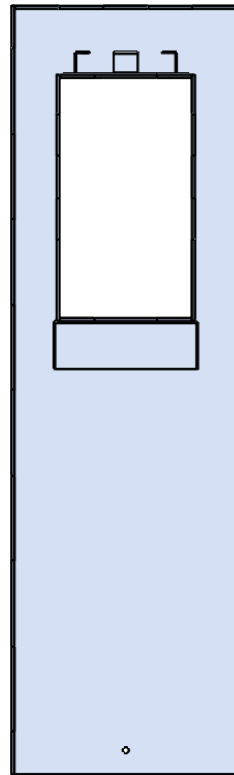
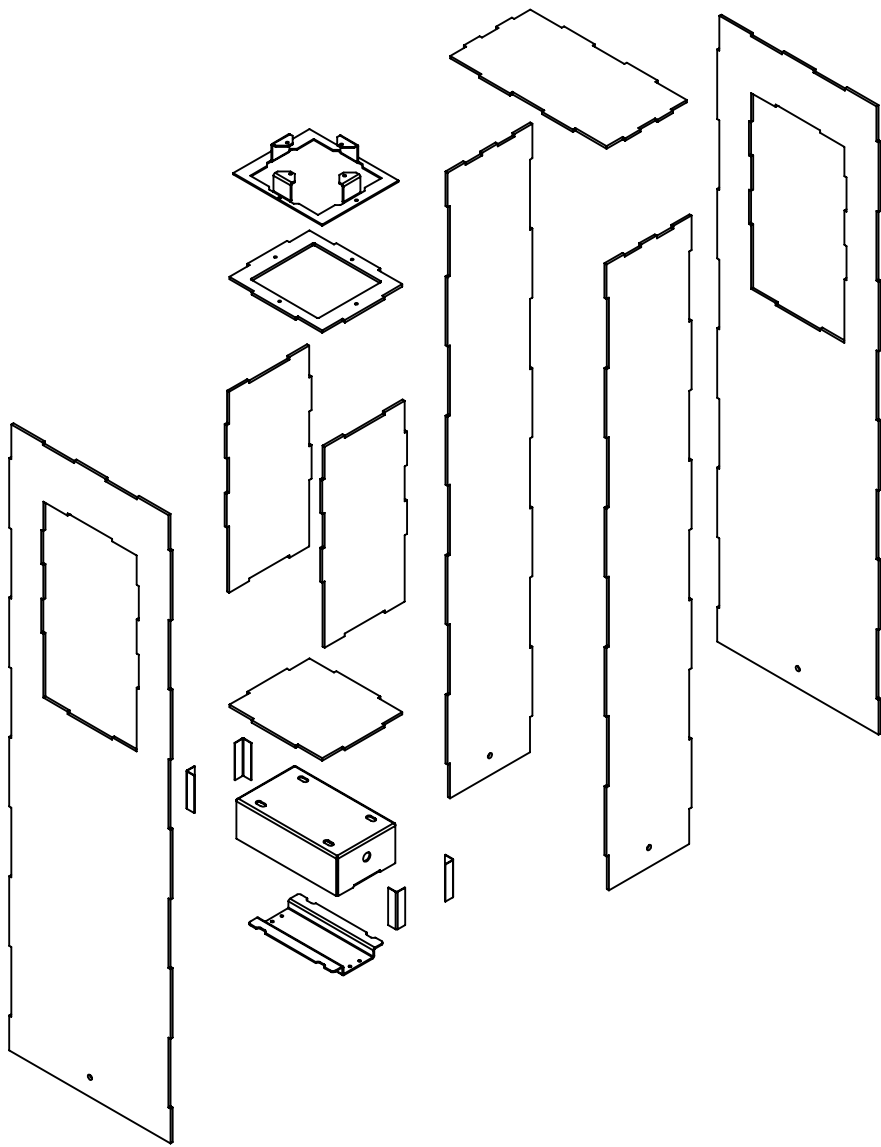

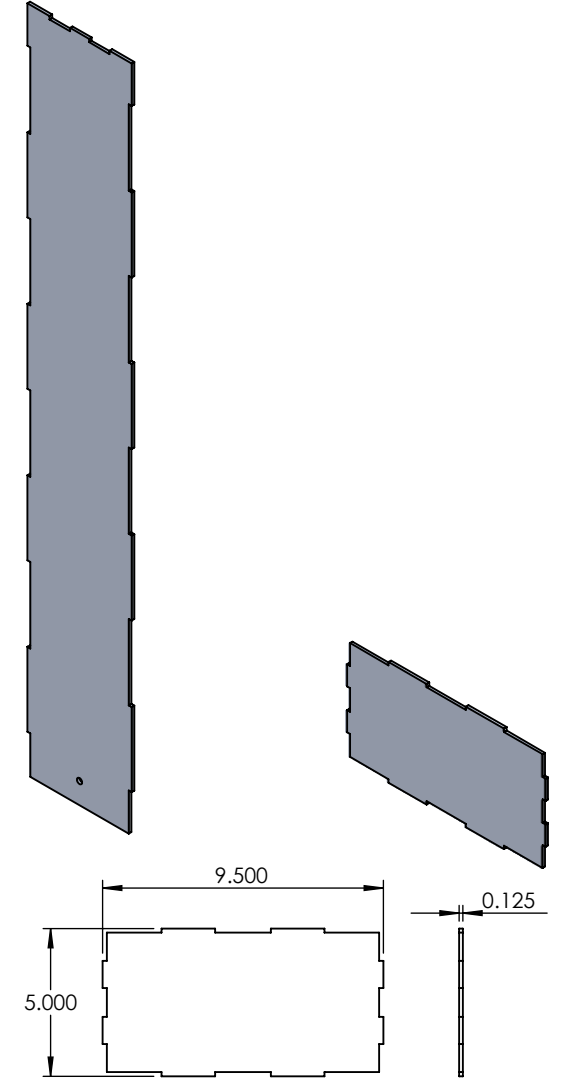
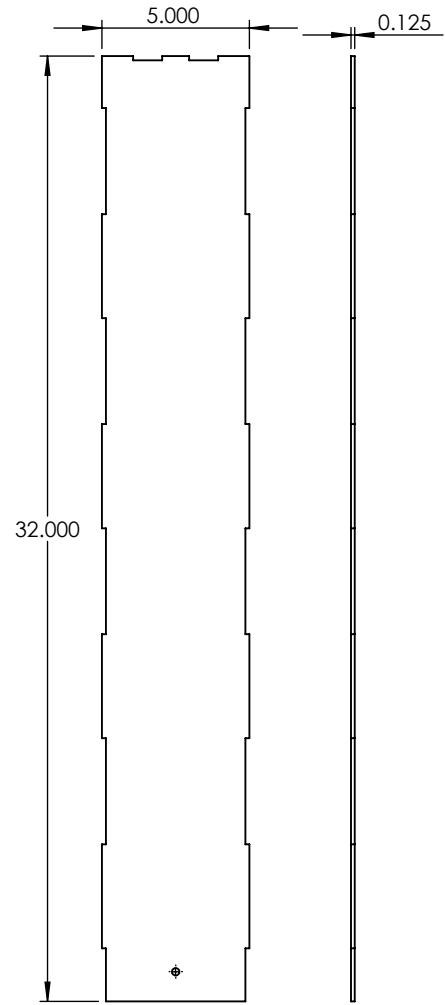
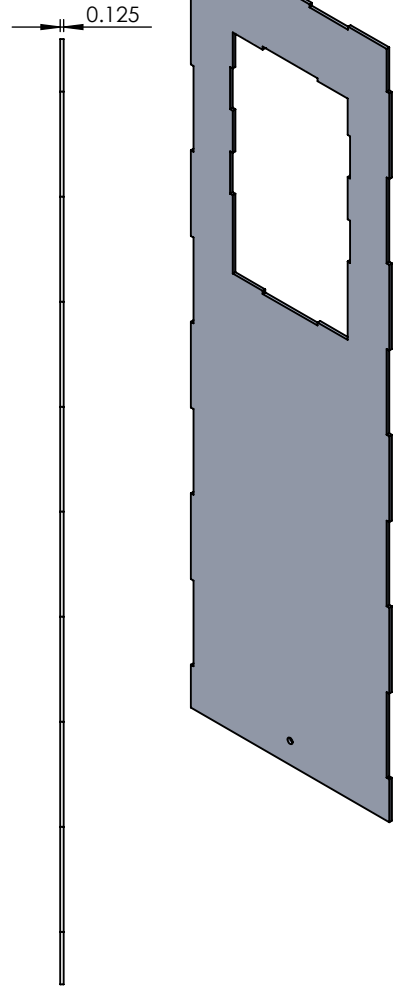
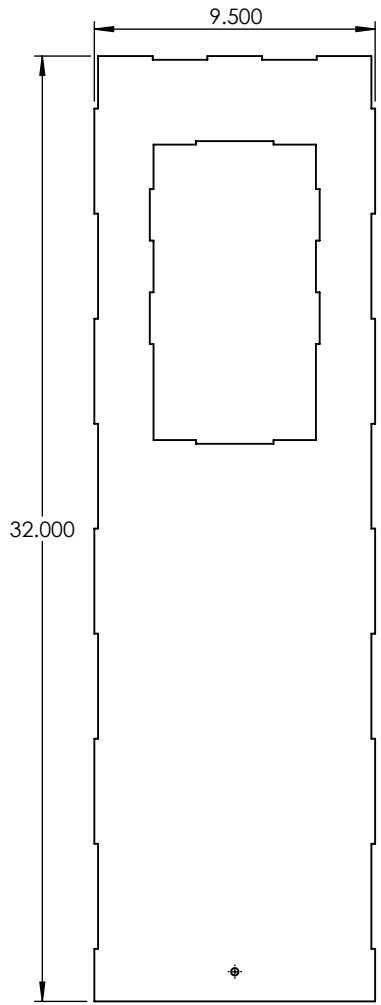

PROPRIETARY AND CONFIDENTIAL
 THE INFORMATION CONTAINED IN THIS DRAWING IS THE SOLE PROPERTY OF <INSERT COMPANY NAME HERE>. ANY REPRODUCTION IN PART OR AS A WHOLE WITHOUT THE WRITTEN PERMISSION OF <INSERT COMPANY NAME HERE> IS PROHIBITED.

		UNLESS OTHERWISE SPECIFIED:		NAME	DATE
		DIMENSIONS ARE IN INCHES	DRAWN		
		TOLERANCES:	CHECKED		
		FRACTIONAL ±	ENG APPR.		
		ANGULAR: MACH ± BEND ±	MFG APPR.		
		TWO PLACE DECIMAL ±	Q.A.		
		THREE PLACE DECIMAL ±	COMMENTS:		
		INTERPRET GEOMETRIC TOLERANCING PER:			
		MATERIAL			
		FINISH			
NEXT ASSY	USED ON				
APPLICATION		DO NOT SCALE DRAWING			

ALUMINUM 0.125" PLATE		
TITLE:		
EC-BOL-2PLR-20W		
SIZE	DWG. NO.	REV
A		
SCALE: 1:6.5WEIGHT:		SHEET 4 OF 10

5

4

3

2

1

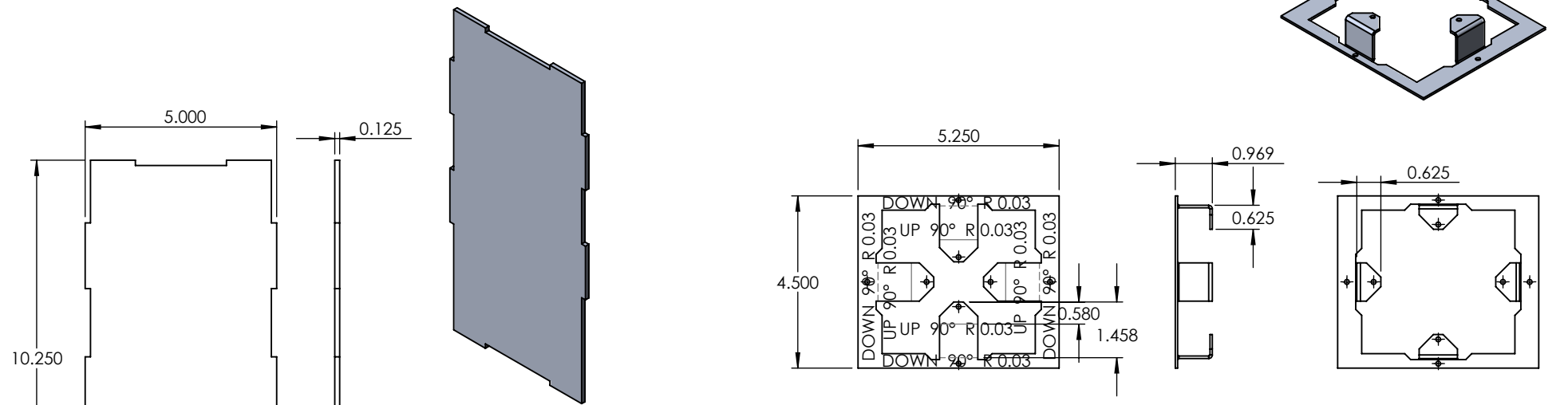
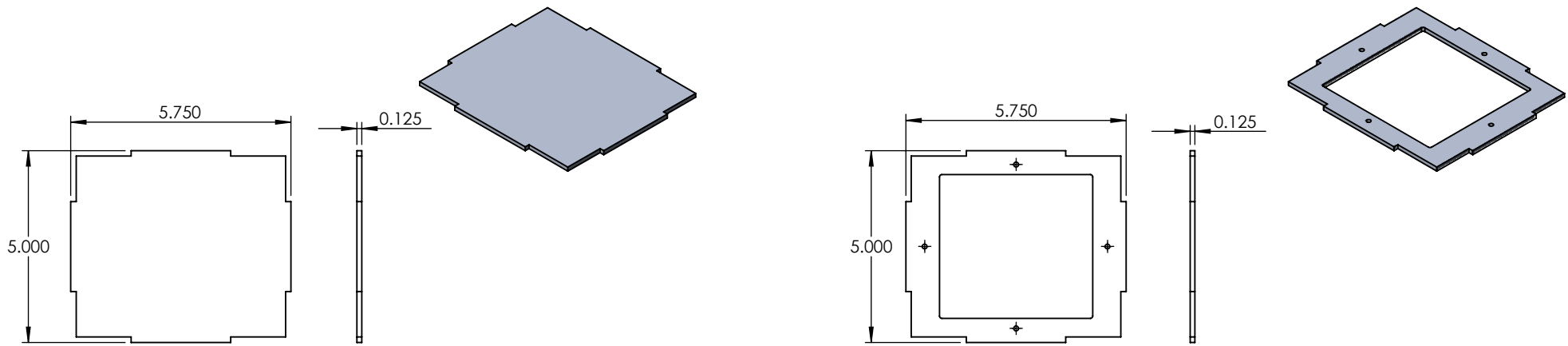

PROPRIETARY AND CONFIDENTIAL
 THE INFORMATION CONTAINED IN THIS DRAWING IS THE SOLE PROPERTY OF <INSERT COMPANY NAME HERE>. ANY REPRODUCTION IN PART OR AS A WHOLE WITHOUT THE WRITTEN PERMISSION OF <INSERT COMPANY NAME HERE> IS PROHIBITED.

		UNLESS OTHERWISE SPECIFIED:		NAME	DATE
		DIMENSIONS ARE IN INCHES	DRAWN		
		TOLERANCES:	CHECKED		
		FRACTIONAL ±	ENG APPR.		
		ANGULAR: MACH ± BEND ±	MFG APPR.		
		TWO PLACE DECIMAL ±	Q.A.		
		THREE PLACE DECIMAL ±	COMMENTS:		
		INTERPRET GEOMETRIC TOLERANCING PER:			
		MATERIAL			
		FINISH			
NEXT ASSY	USED ON				
APPLICATION		DO NOT SCALE DRAWING			

ALUMINUM 0.125" PLATE		
TITLE:		
EC-BOL-2PLR-20W		
SIZE	DWG. NO.	REV
A		
SCALE: 1:4	WEIGHT:	SHEET 5 OF 10

5

4

3

2

1

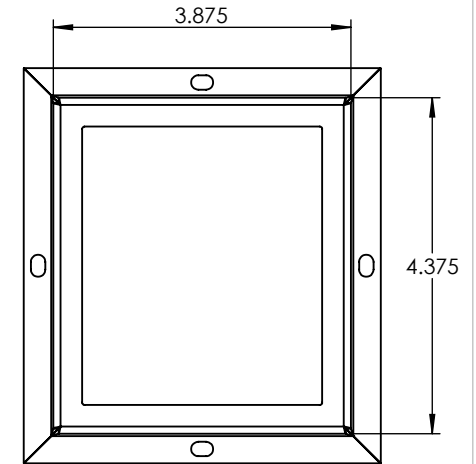
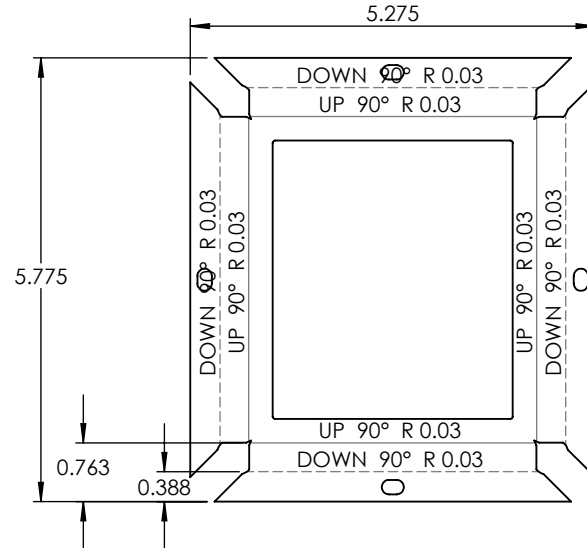
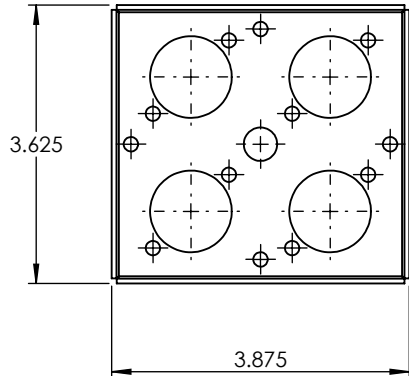
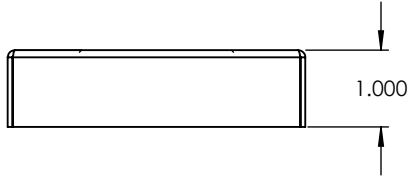
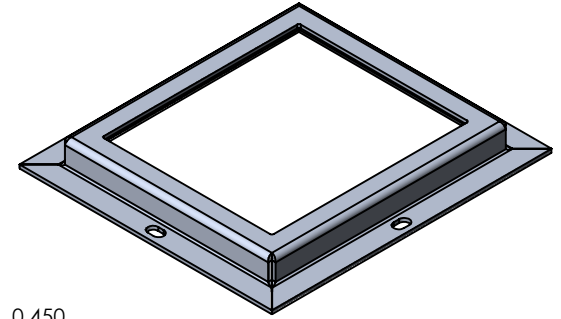
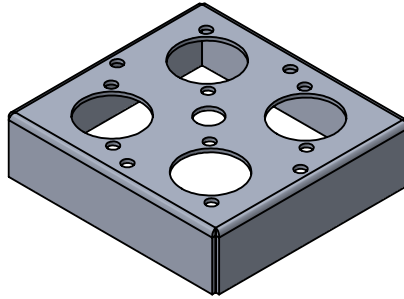
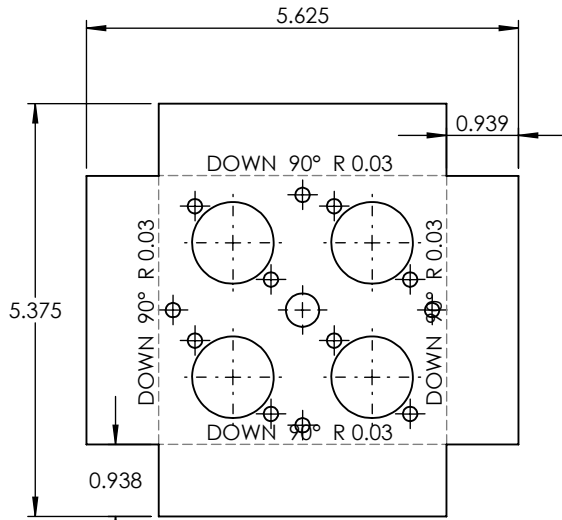

PROPRIETARY AND CONFIDENTIAL
 THE INFORMATION CONTAINED IN THIS DRAWING IS THE SOLE PROPERTY OF <INSERT COMPANY NAME HERE>. ANY REPRODUCTION IN PART OR AS A WHOLE WITHOUT THE WRITTEN PERMISSION OF <INSERT COMPANY NAME HERE> IS PROHIBITED.

		UNLESS OTHERWISE SPECIFIED:		NAME	DATE	ALUMINUM 0.0635"	
		DIMENSIONS ARE IN INCHES	DRAWN			TITLE:	
		TOLERANCES:	CHECKED			EC-BOL-2PLR-20W	
		FRACTIONAL ±	ENG APPR.			SIZE	DWG. NO.
		ANGULAR: MACH ± BEND ±	MFG APPR.			A	REV
		TWO PLACE DECIMAL ±	Q.A.			SCALE: 1:2.5WEIGHT:	
		THREE PLACE DECIMAL ±	COMMENTS:			SHEET 6 OF 10	
		INTERPRET GEOMETRIC TOLERANCING PER:					
		MATERIAL					
	NEXT ASSY	FINISH					
		USED ON					
	APPLICATION	DO NOT SCALE DRAWING					

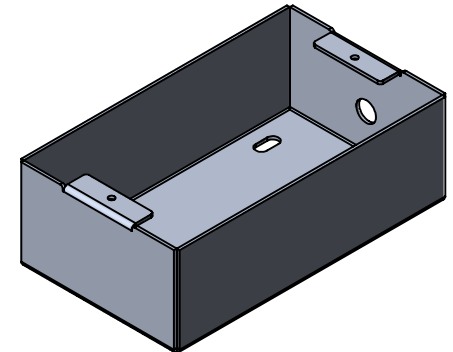
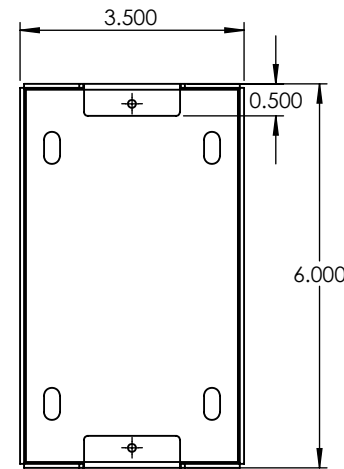
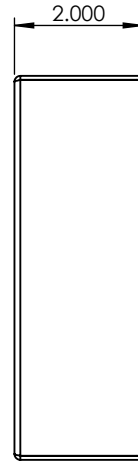
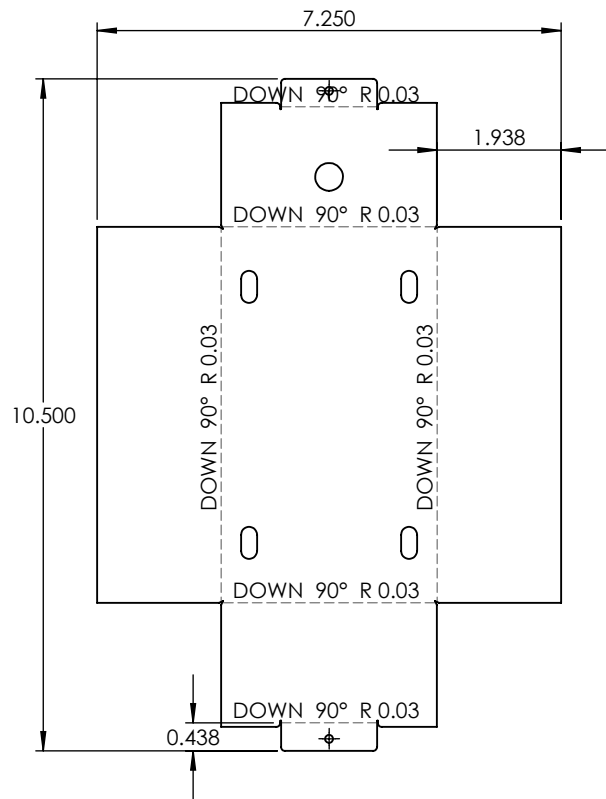
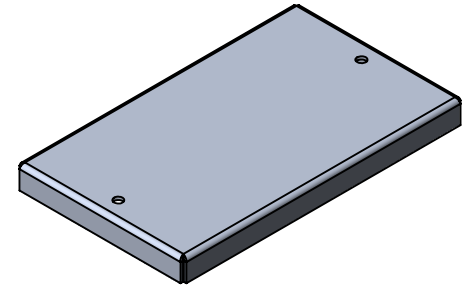
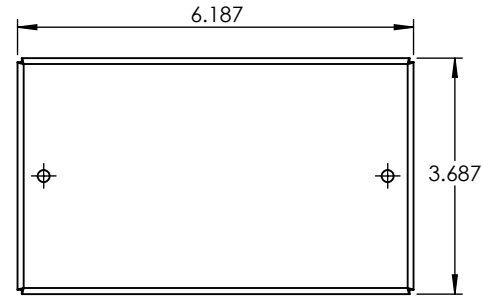
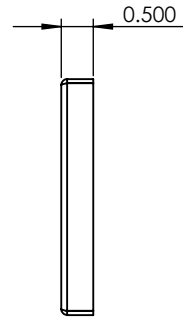
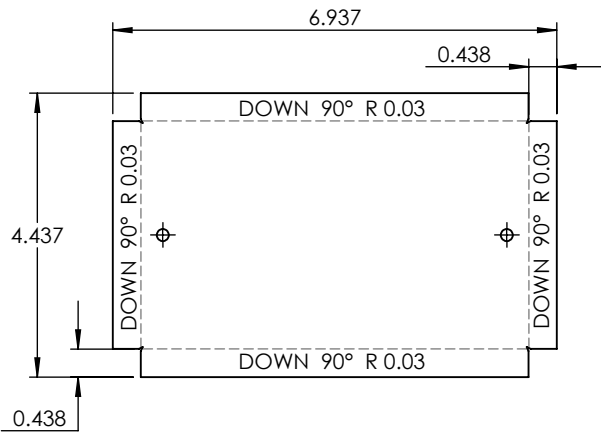

UNLESS OTHERWISE SPECIFIED:		NAME	DATE	ALUMINUM 0.0635"	
DIMENSIONS ARE IN INCHES		DRAWN		TITLE:	
TOLERANCES:		CHECKED		EC-BOL-2PLR-20W	
FRACTIONAL ±		ENG APPR.		SIZE	DWG. NO.
ANGULAR: MACH ± BEND ±		MFG APPR.		A	REV
TWO PLACE DECIMAL ±		Q.A.		SCALE: 1:3	WEIGHT:
THREE PLACE DECIMAL ±		COMMENTS:			SHEET 7 OF 10
INTERPRET GEOMETRIC TOLERANCING PER:					
MATERIAL					
FINISH					
NEXT ASSY	USED ON				
APPLICATION		DO NOT SCALE DRAWING			

PROPRIETARY AND CONFIDENTIAL
 THE INFORMATION CONTAINED IN THIS DRAWING IS THE SOLE PROPERTY OF <INSERT COMPANY NAME HERE>. ANY REPRODUCTION IN PART OR AS A WHOLE WITHOUT THE WRITTEN PERMISSION OF <INSERT COMPANY NAME HERE> IS PROHIBITED.

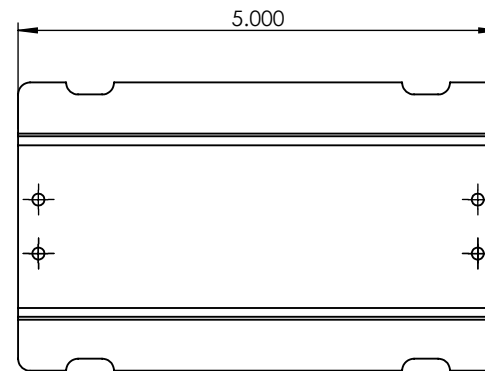
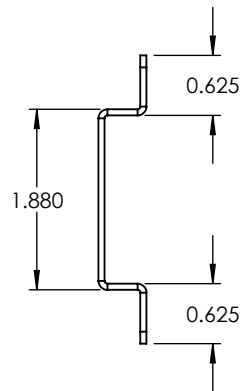
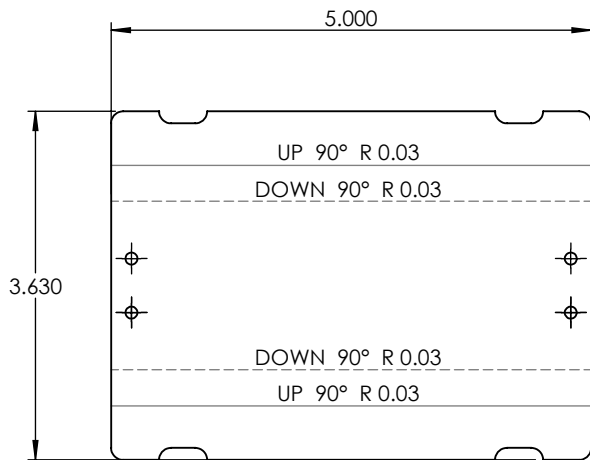
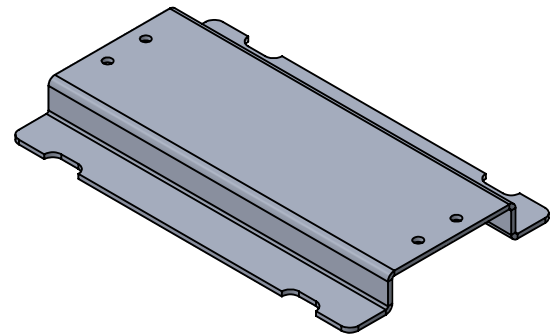

PROPRIETARY AND CONFIDENTIAL
 THE INFORMATION CONTAINED IN THIS DRAWING IS THE SOLE PROPERTY OF <INSERT COMPANY NAME HERE>. ANY REPRODUCTION IN PART OR AS A WHOLE WITHOUT THE WRITTEN PERMISSION OF <INSERT COMPANY NAME HERE> IS PROHIBITED.

NEXT ASSY	USED ON
APPLICATION	

UNLESS OTHERWISE SPECIFIED:
DIMENSIONS ARE IN INCHES TOLERANCES: FRACTIONAL ± ANGULAR: MACH ± BEND ± TWO PLACE DECIMAL ± THREE PLACE DECIMAL ±
INTERPRET GEOMETRIC TOLERANCING PER:
MATERIAL
FINISH
DO NOT SCALE DRAWING

NAME	DATE
DRAWN	
CHECKED	
ENG APPR.	
MFG APPR.	
Q.A.	
COMMENTS:	

ALUMINUM 0.0635"		
TITLE: EC-BOL-2PLR-20W		
SIZE A	DWG. NO.	REV
SCALE: 1:2	WEIGHT:	SHEET 8 OF 10

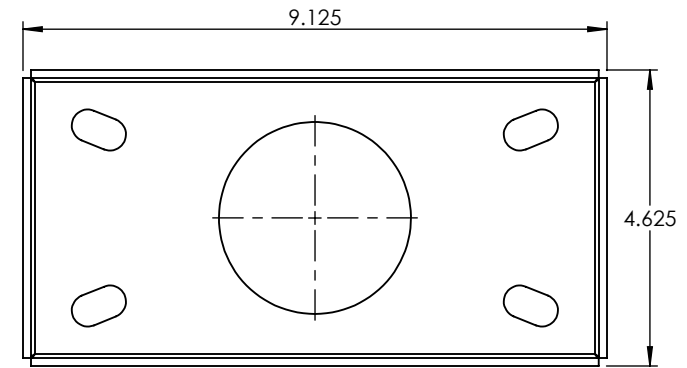
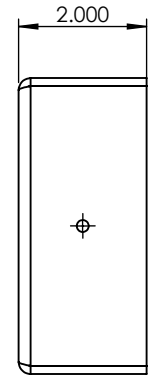
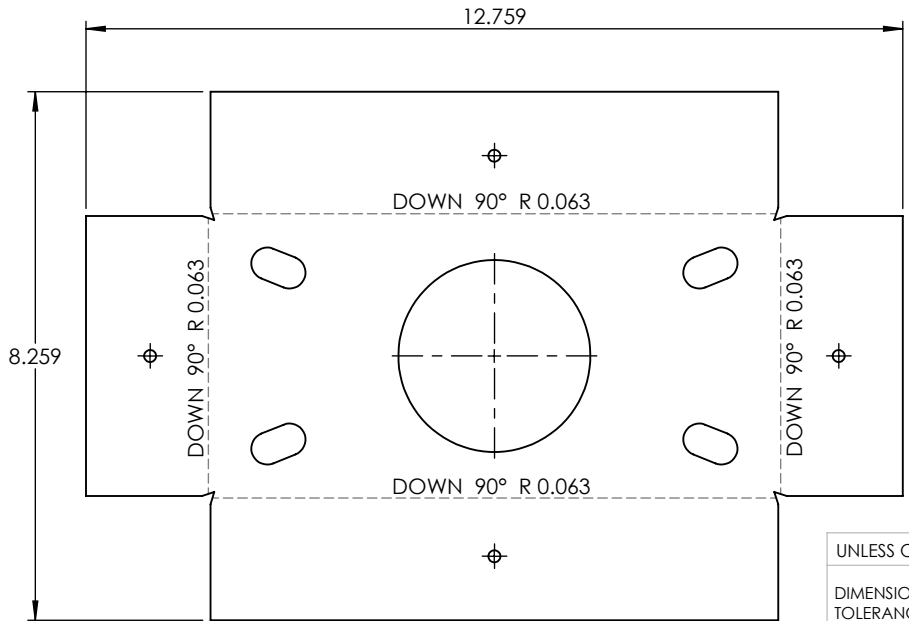
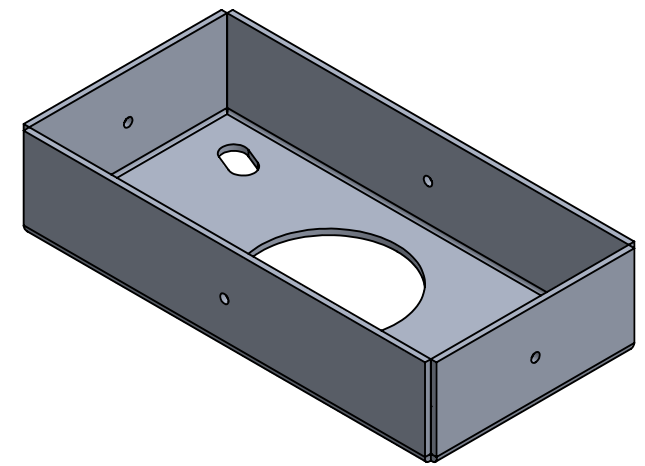
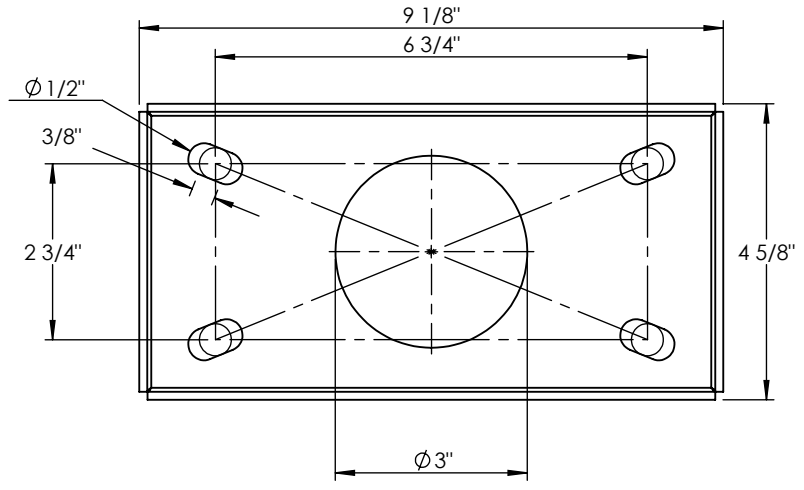

UNLESS OTHERWISE SPECIFIED:

DIMENSIONS ARE IN INCHES
 TOLERANCES:
 FRACTIONAL ±
 ANGULAR: MACH ± BEND ±
 TWO PLACE DECIMAL ±
 THREE PLACE DECIMAL ±

INTERPRET GEOMETRIC TOLERANCING PER:

MATERIAL

FINISH

DO NOT SCALE DRAWING

	NAME	DATE
DRAWN		
CHECKED		
ENG APPR.		
MFG APPR.		
Q.A.		

COMMENTS:

ALUMINUM 0.125" PLATE

TITLE:

EC-BOL-2PLR-20W

SIZE	DWG. NO.	REV
A		
SCALE: 1:3	WEIGHT:	SHEET 9 OF 10

PROPRIETARY AND CONFIDENTIAL
 THE INFORMATION CONTAINED IN THIS DRAWING IS THE SOLE PROPERTY OF <INSERT COMPANY NAME HERE>. ANY REPRODUCTION IN PART OR AS A WHOLE WITHOUT THE WRITTEN PERMISSION OF <INSERT COMPANY NAME HERE> IS PROHIBITED.

NEXT ASSY	USED ON	APPLICATION

5

4

3

2

1

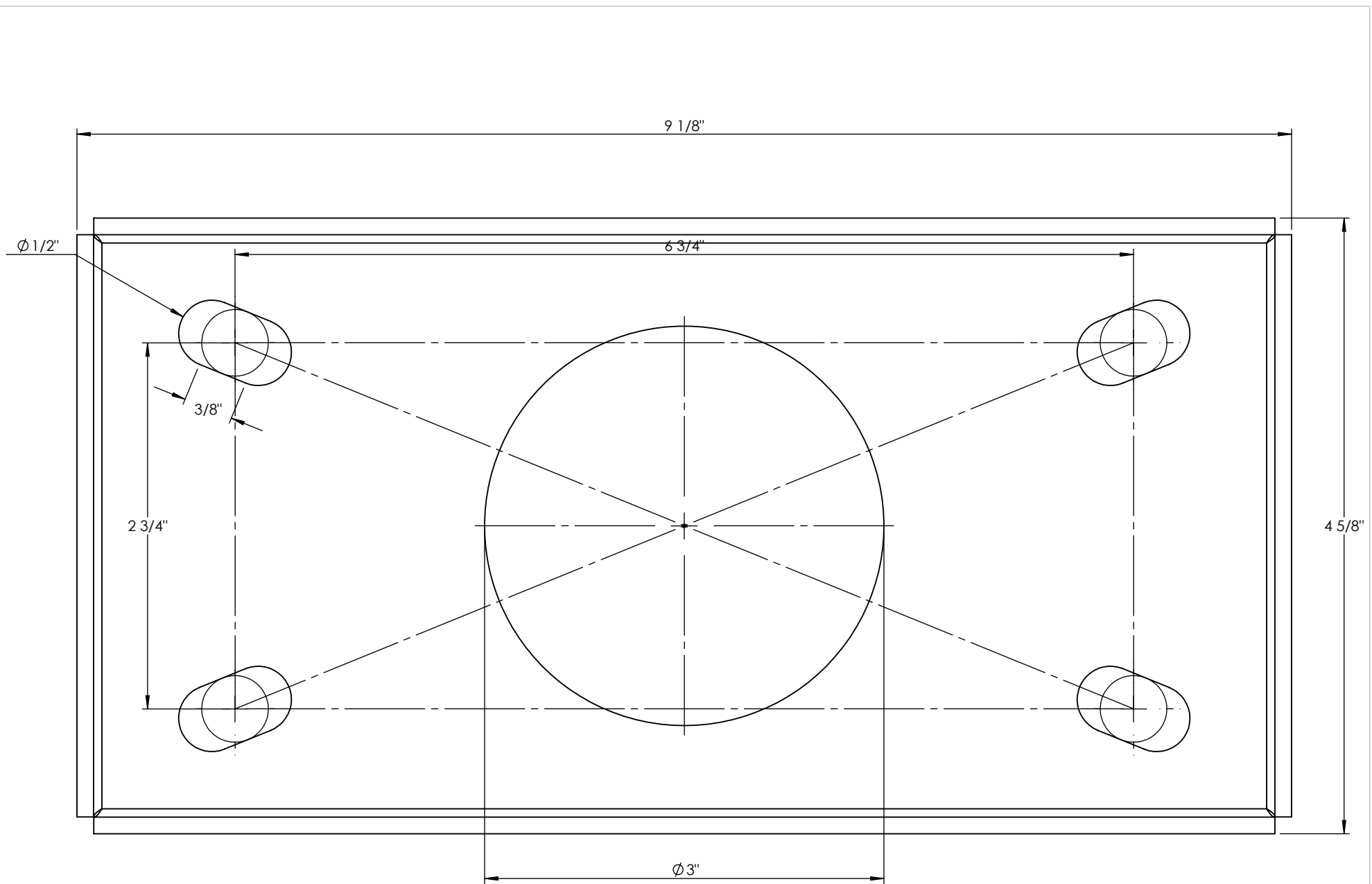

**3/8" X 12" LONG
ANCHOR BOLT SIZE**