

ITEM NO.	PART NUMBER	DESCRIPTION	QTY.	CUT
1	EC-BX-CAV-12W-FRAME TUBE	5"X5" ALUMINUM POST	1	
2	EC-BX-CAV-12W-ANCHOR PLATE	ALUMINUM 0.125" PLATE	1	
3	EC-BX-CAV-12W-TOP PLATE	ALUMINUM 0.125" PLATE	1	
4	EC-BX-CAV-12W-OPEN SPACE SIDE PLATE	ALUMINUM 0.125" PLATE	1	
5	EC-BX-CAV-12W-TOP PLATE BRACKET	ALUMINUM 00635"	1	
6	EC-BX-CAV-12W-FRAME PLATE BRACKET	ALUMINUM 0.0635"	1	
7	EC-BX-CAV-12W-LED PLATE	ALUMINUM 0.0635"	1	
8	EC-BX-CAV-12W-DRIVER BRACKET	ALUMINUM 0.0635"	1	
9	EC-BX-CAV-12W-ACRYLIC	ACRYLIC	1	
10	55MM HEXAGON HEAT SINK	HEAT SINK	1	
11	DS-15W-350C1542010-3001	DRIVER	1	
12	Altailed_PCN_D1500_110B-10 WATT	LED	1	

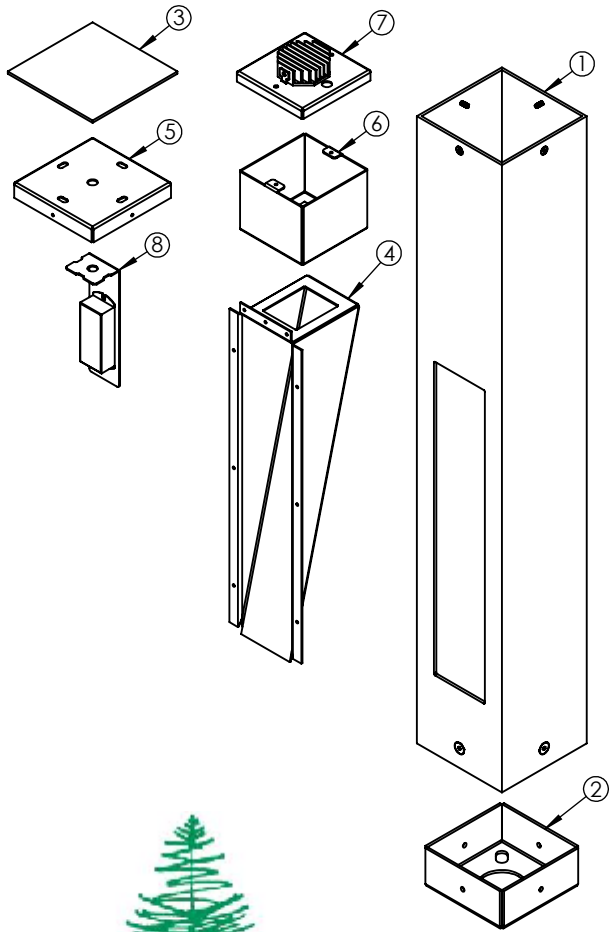

**EVERGREEN LIGHTING**

ALL BEND RADIUS .030"

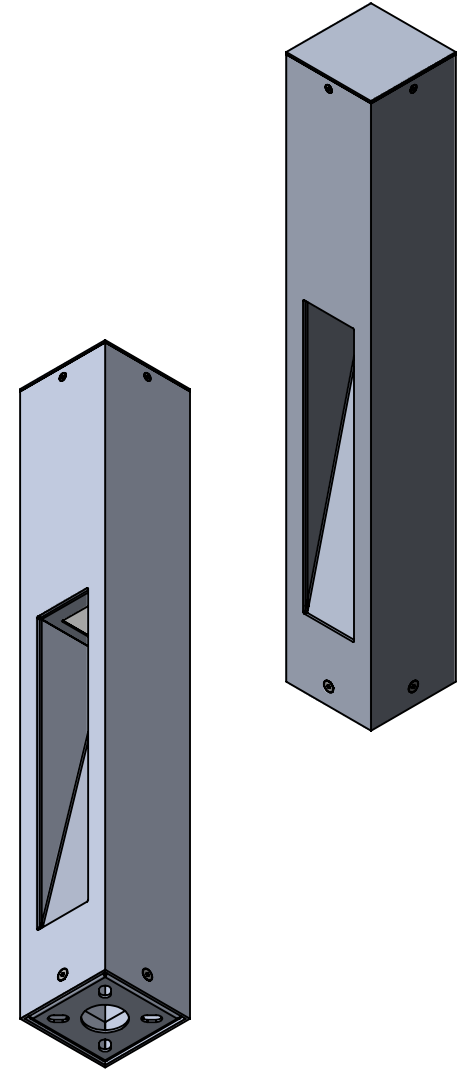
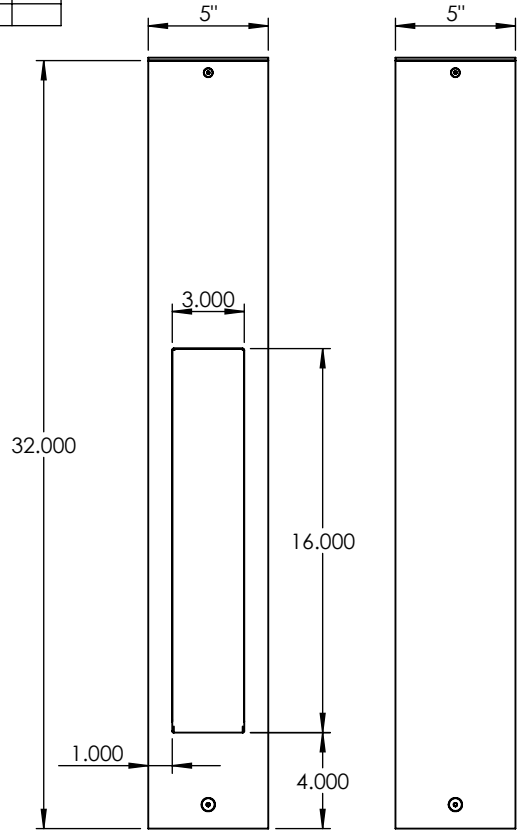

UNLESS OTHERWISE SPECIFIED:		NAME	DATE	TITLE:  EC-BX-CAV-12W	
DIMENSIONS ARE IN INCHES TOLERANCES: FRACTIONAL ± .003 ANGULAR: MACH ± .01 BEND ± TWO PLACE DECIMAL ± THREE PLACE DECIMAL ±.001		DRAWN			
INTERPRET GEOMETRIC TOLERANCING PER:		CHECKED		A	
MATERIAL		ENG APPR.			
FINISH		MFG APPR.		SHEET 1 OF 9	
APPLICATION		Q.A.			
DO NOT SCALE DRAWING		COMMENTS:			

5

4

3

2

1

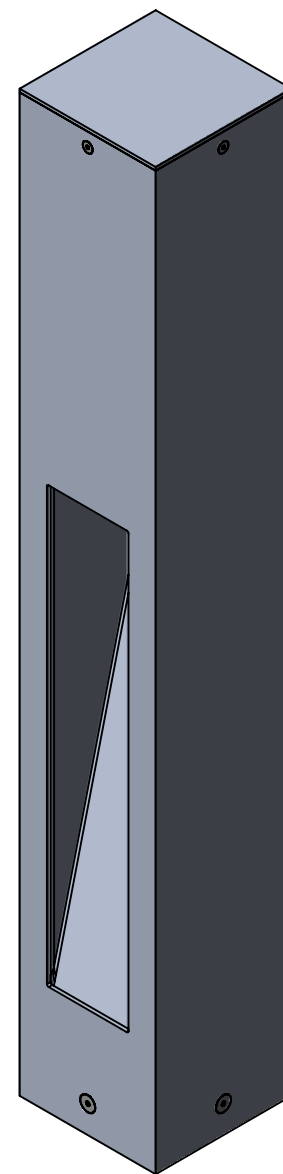
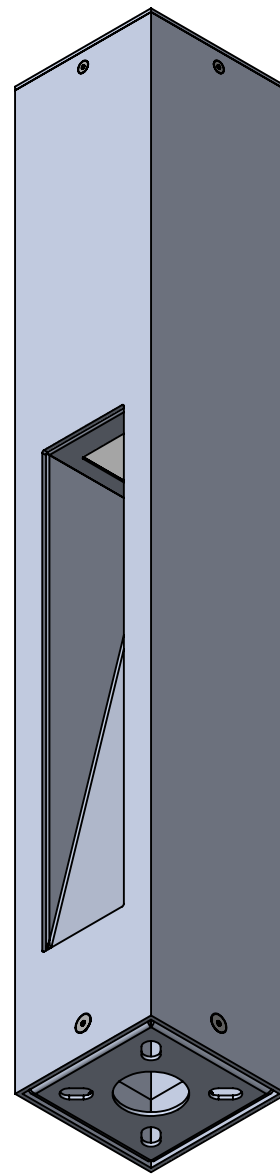
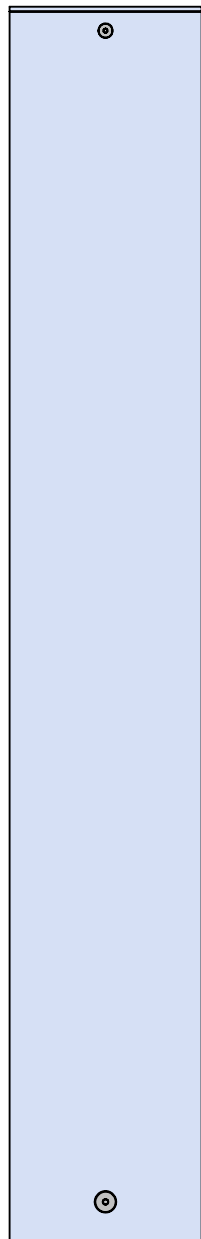
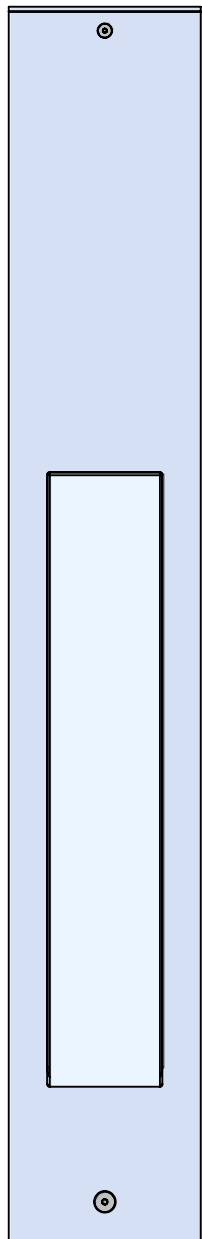

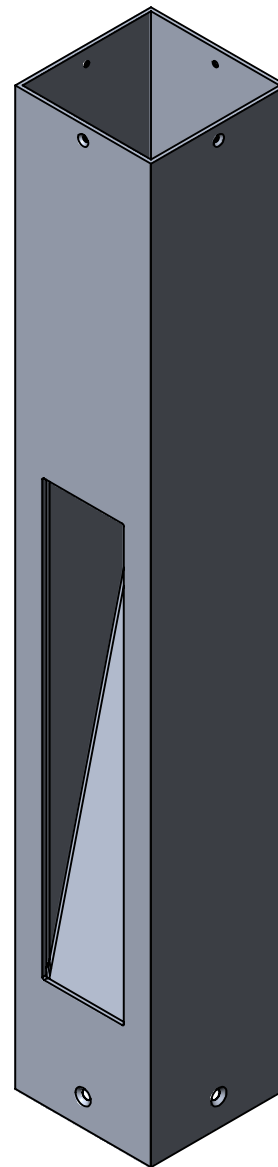
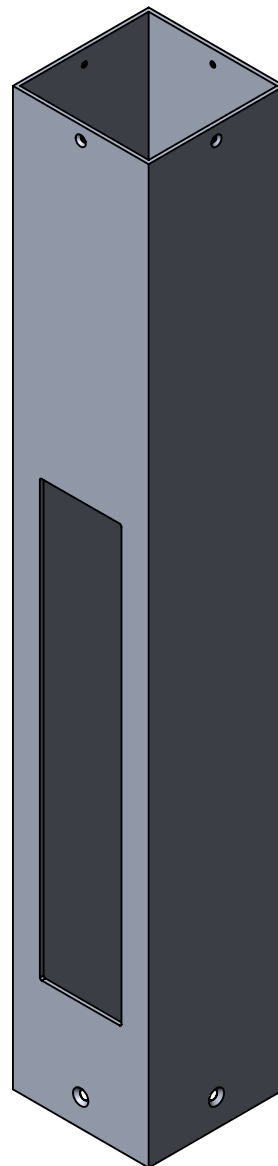
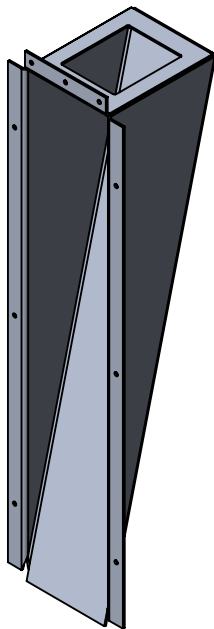
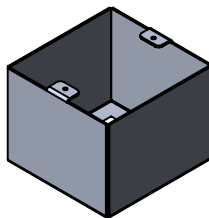
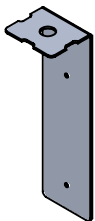
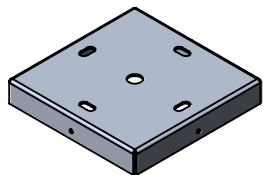
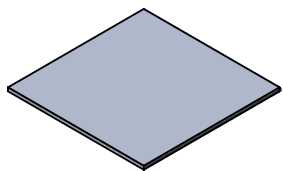
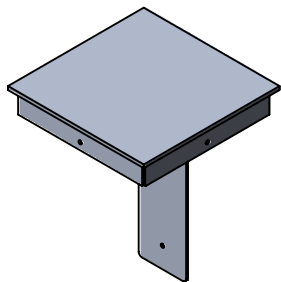

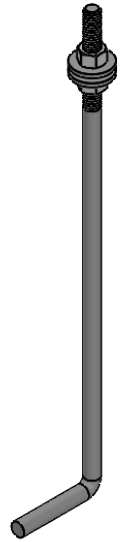
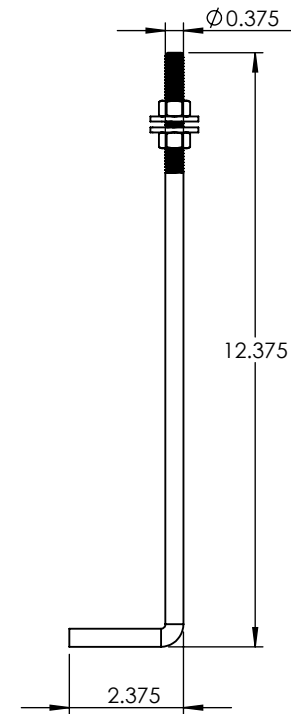
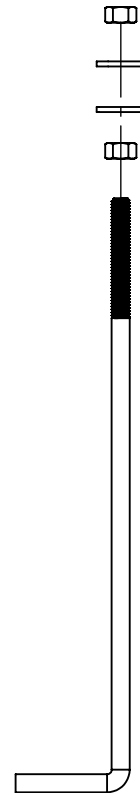
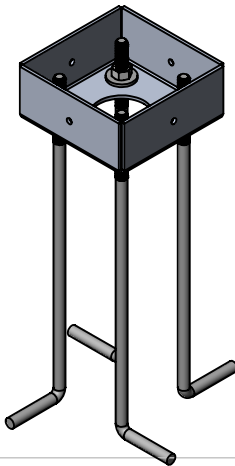
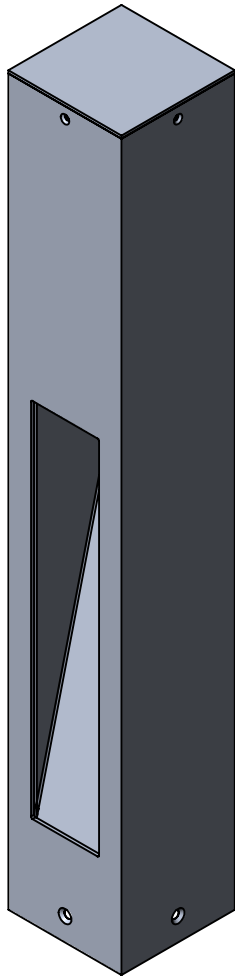

**3/8" X 12" LONG  
ANCHOR BOLT SIZE**

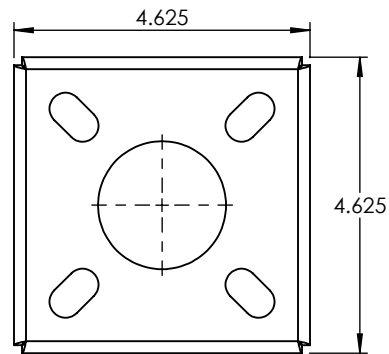
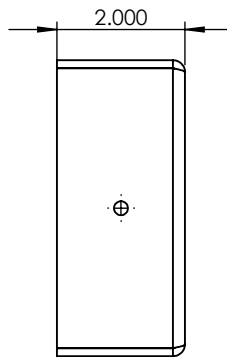
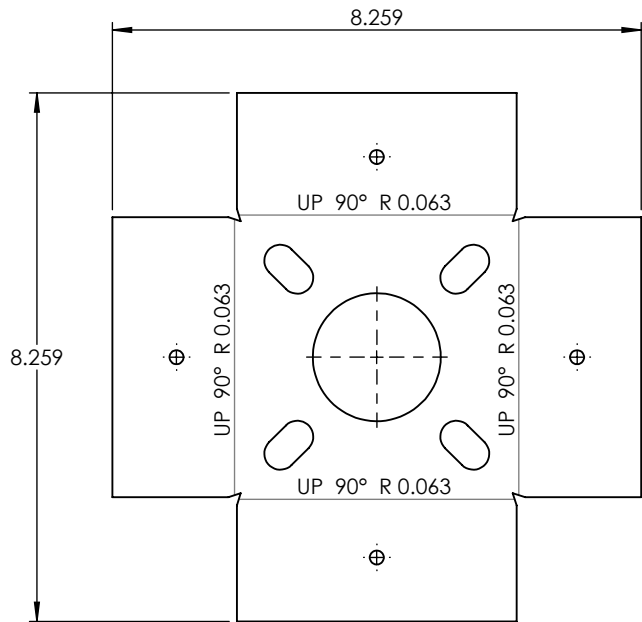
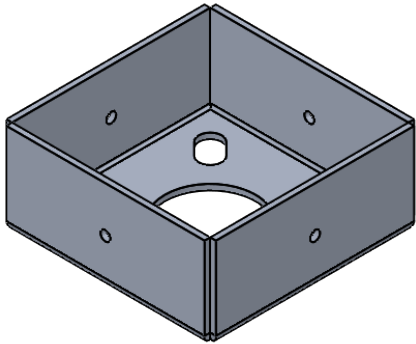

**PROPRIETARY AND CONFIDENTIAL**  
 THE INFORMATION CONTAINED IN THIS DRAWING IS THE SOLE PROPERTY OF <INSERT COMPANY NAME HERE>. ANY REPRODUCTION IN PART OR AS A WHOLE WITHOUT THE WRITTEN PERMISSION OF <INSERT COMPANY NAME HERE> IS PROHIBITED.

		UNLESS OTHERWISE SPECIFIED:		NAME	DATE
		DIMENSIONS ARE IN INCHES	DRAWN		
		TOLERANCES:	CHECKED		
		FRACTIONAL ±	ENG APPR.		
		ANGULAR: MACH ± BEND ±	MFG APPR.		
		TWO PLACE DECIMAL ±	Q.A.		
		THREE PLACE DECIMAL ±	COMMENTS:		
		INTERPRET GEOMETRIC TOLERANCING PER:			
		MATERIAL			
NEXT ASSY	USED ON	FINISH			
APPLICATION		DO NOT SCALE DRAWING			

**ALUMINUM 0.125" PLATE**

TITLE:  
 EC-BX-CAV-12W

SIZE	DWG. NO.	REV
<b>A</b>		
SCALE: 1:3	WEIGHT:	SHEET 5 OF 9

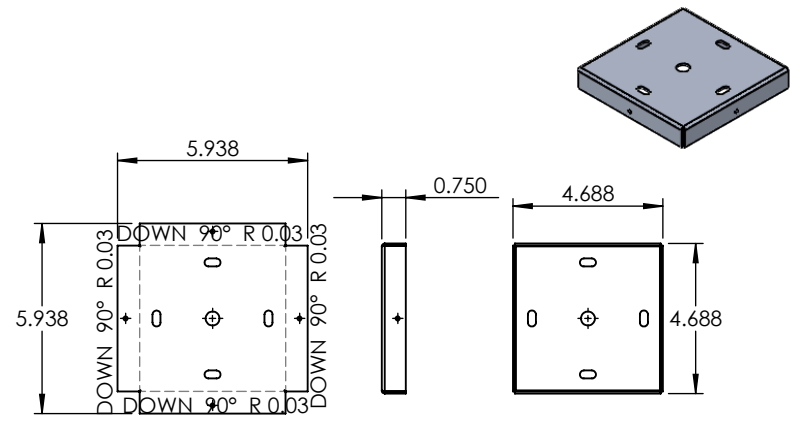
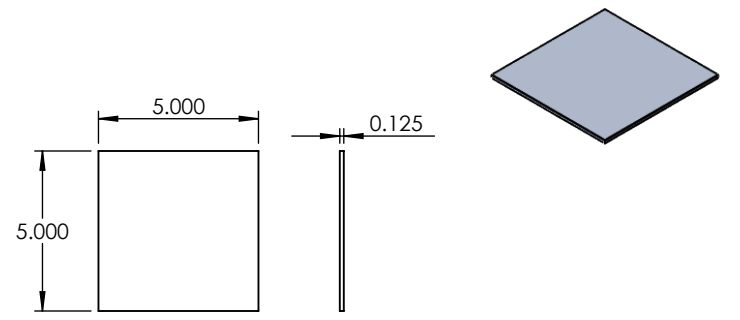
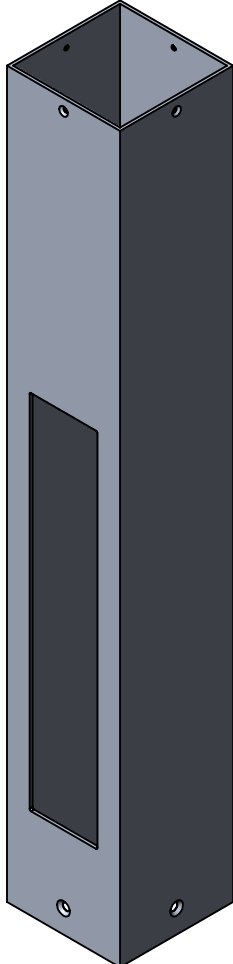
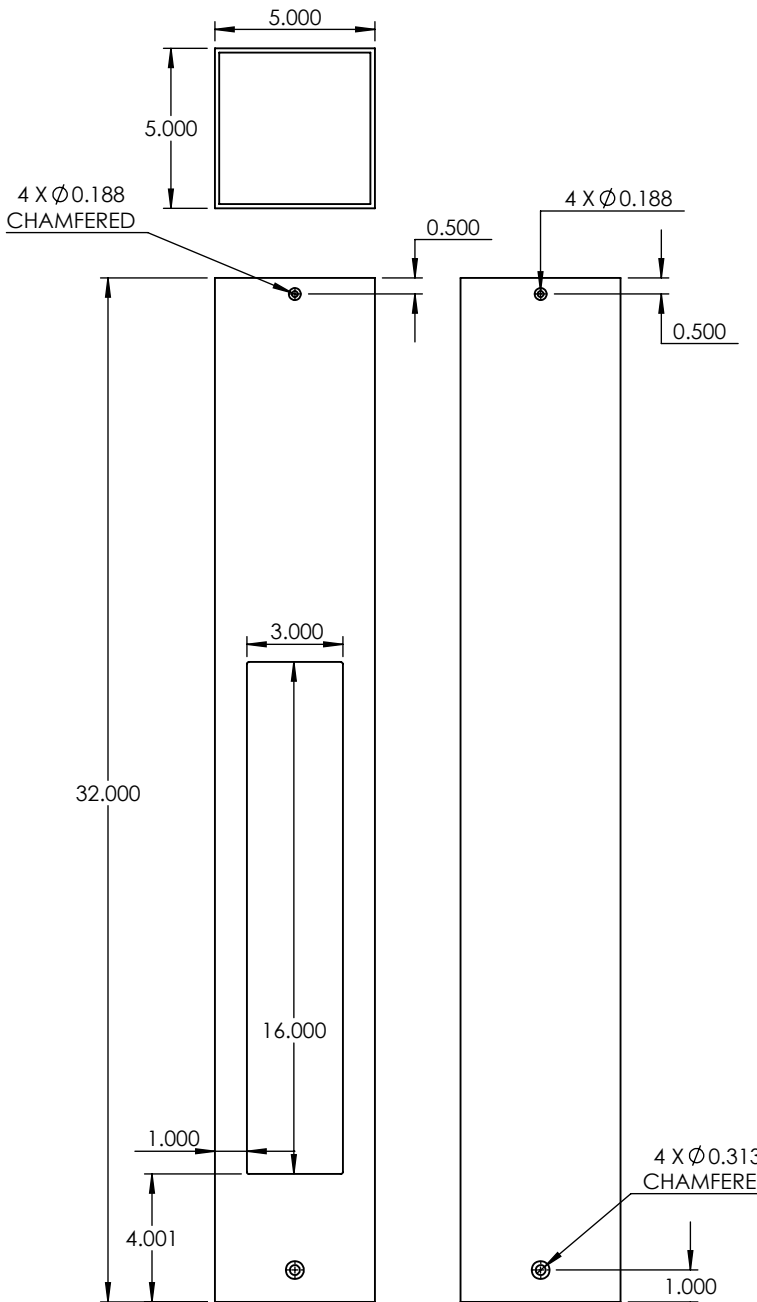

**PROPRIETARY AND CONFIDENTIAL**  
 THE INFORMATION CONTAINED IN THIS DRAWING IS THE SOLE PROPERTY OF <INSERT COMPANY NAME HERE>. ANY REPRODUCTION IN PART OR AS A WHOLE WITHOUT THE WRITTEN PERMISSION OF <INSERT COMPANY NAME HERE> IS PROHIBITED.

NEXT ASSY	USED ON
APPLICATION	

UNLESS OTHERWISE SPECIFIED:	NAME	DATE
DIMENSIONS ARE IN INCHES	DRAWN	
TOLERANCES:	CHECKED	
FRACTIONAL ±	ENG APPR.	
ANGULAR: MACH ± BEND ±	MFG APPR.	
TWO PLACE DECIMAL ±	Q.A.	
THREE PLACE DECIMAL ±	COMMENTS:	
INTERPRET GEOMETRIC TOLERANCING PER:		
MATERIAL		
FINISH		
DO NOT SCALE DRAWING		

<b>5"X5" ALUMINUM POST</b>		
TITLE:		
<b>EC-BX-CAV-12W</b>		
SIZE	DWG. NO.	REV
<b>A</b>		
SCALE: 1:6	WEIGHT:	SHEET 6 OF 9

5

4

3

2

1

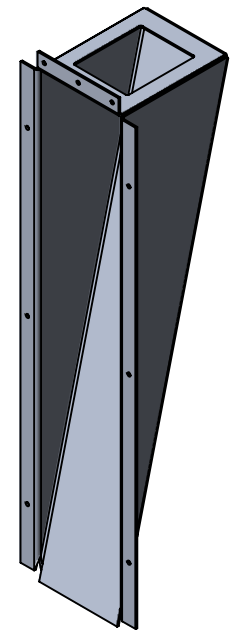
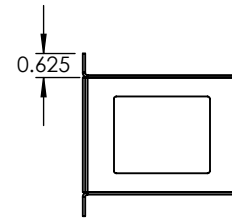
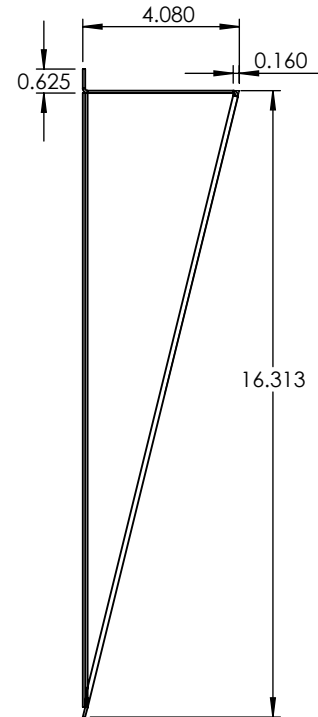
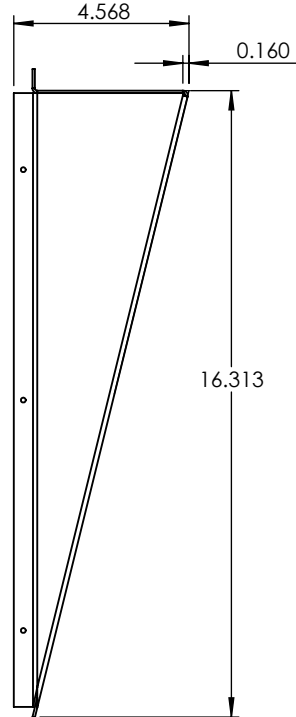
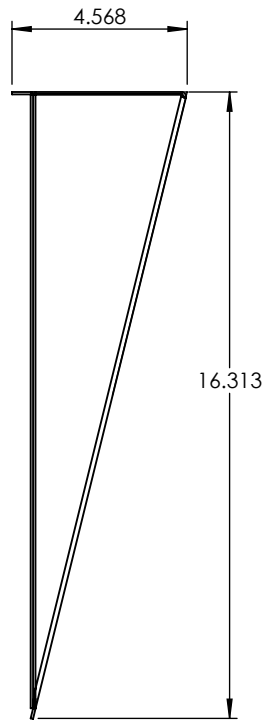
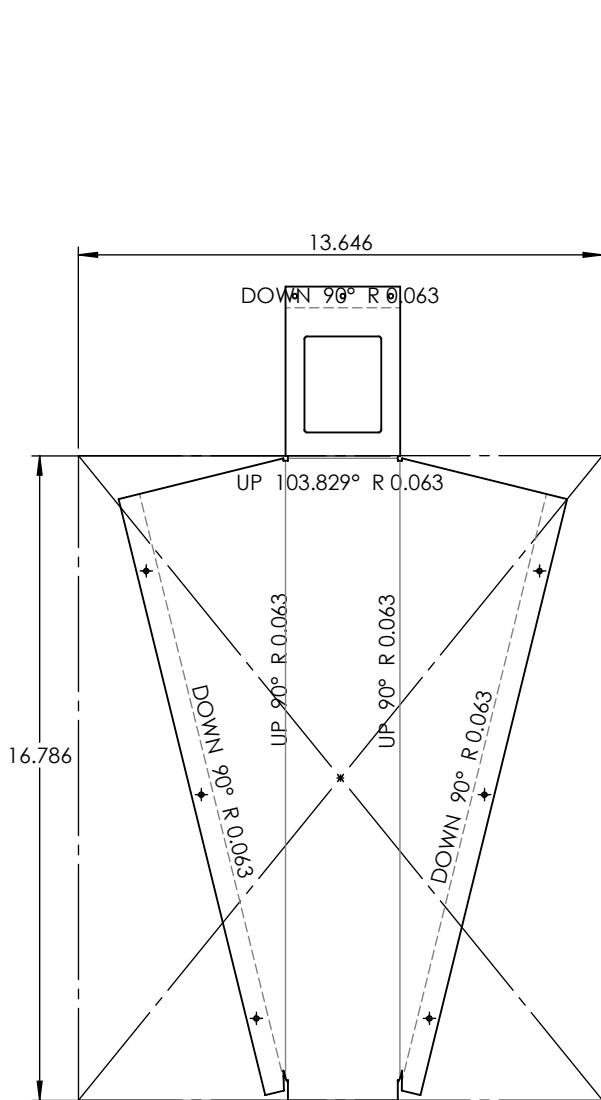

UNLESS OTHERWISE SPECIFIED:		NAME	DATE	ALUMINUM 0.125" PLATE	
DIMENSIONS ARE IN INCHES		DRAWN		TITLE:  EC-BX-CAV-12W	
TOLERANCES:		CHECKED			
FRACTIONAL ±		ENG APPR.			
ANGULAR: MACH ± BEND ±		MFG APPR.			
TWO PLACE DECIMAL ±		Q.A.		SIZE	DWG. NO.
THREE PLACE DECIMAL ±		COMMENTS:		<b>A</b>	
INTERPRET GEOMETRIC TOLERANCING PER:				SCALE: 1:5	WEIGHT:
MATERIAL					SHEET 7 OF 9
FINISH					
APPLICATION					
DO NOT SCALE DRAWING					

**PROPRIETARY AND CONFIDENTIAL**  
 THE INFORMATION CONTAINED IN THIS DRAWING IS THE SOLE PROPERTY OF <INSERT COMPANY NAME HERE>. ANY REPRODUCTION IN PART OR AS A WHOLE WITHOUT THE WRITTEN PERMISSION OF <INSERT COMPANY NAME HERE> IS PROHIBITED.

NEXT ASSY	USED ON
APPLICATION	
DO NOT SCALE DRAWING	

5

4

3

2

1

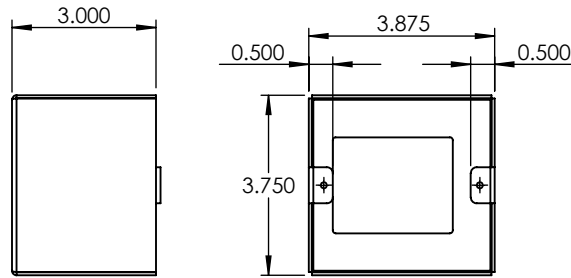
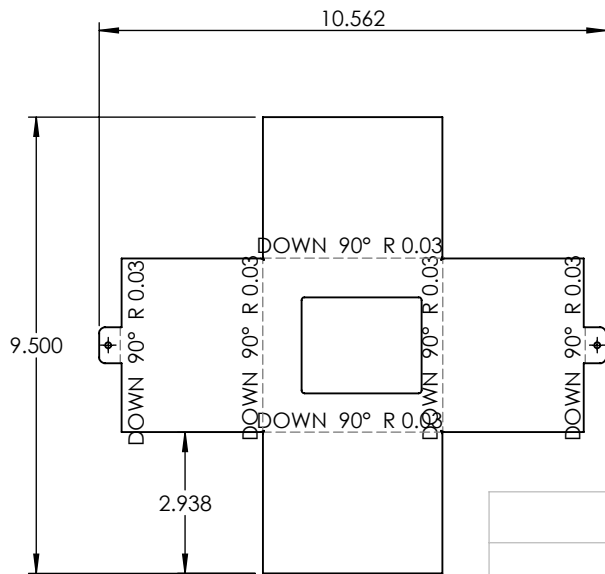
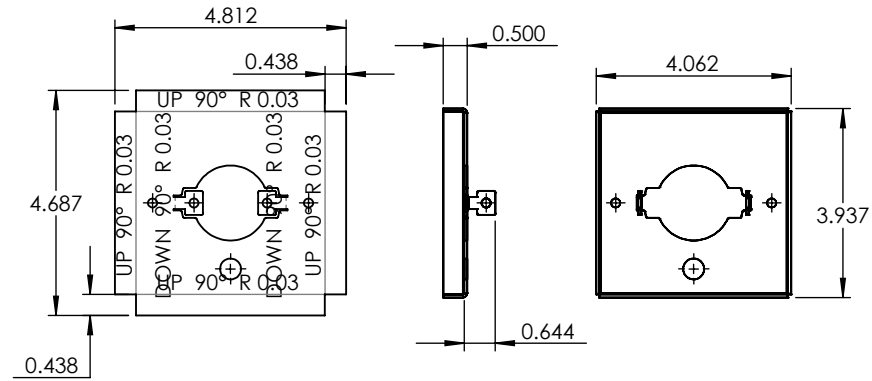
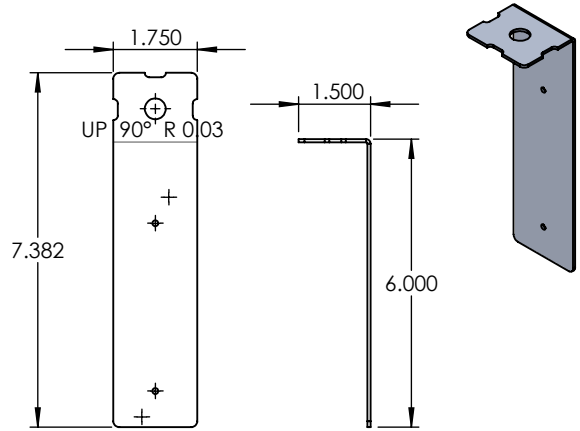

**PROPRIETARY AND CONFIDENTIAL**  
 THE INFORMATION CONTAINED IN THIS DRAWING IS THE SOLE PROPERTY OF <INSERT COMPANY NAME HERE>. ANY REPRODUCTION IN PART OR AS A WHOLE WITHOUT THE WRITTEN PERMISSION OF <INSERT COMPANY NAME HERE> IS PROHIBITED.

		UNLESS OTHERWISE SPECIFIED:		NAME	DATE	ALUMINUM 0.0635"		
		DIMENSIONS ARE IN INCHES		DRAWN		TITLE:		
		TOLERANCES:		CHECKED		EC-BX-CAV-12W		
		FRACTIONAL ±		ENG APPR.		SIZE DWG. NO. REV		
		ANGULAR: MACH ± BEND ±		MFG APPR.		SCALE: 1:4 WEIGHT: SHEET 8 OF 9		
		TWO PLACE DECIMAL ±		Q.A.				
		THREE PLACE DECIMAL ±		COMMENTS:				
		INTERPRET GEOMETRIC TOLERANCING PER:						
		MATERIAL						
		FINISH						
	NEXT ASSY	USED ON						
	APPLICATION	DO NOT SCALE DRAWING						

5

4

3

2

1



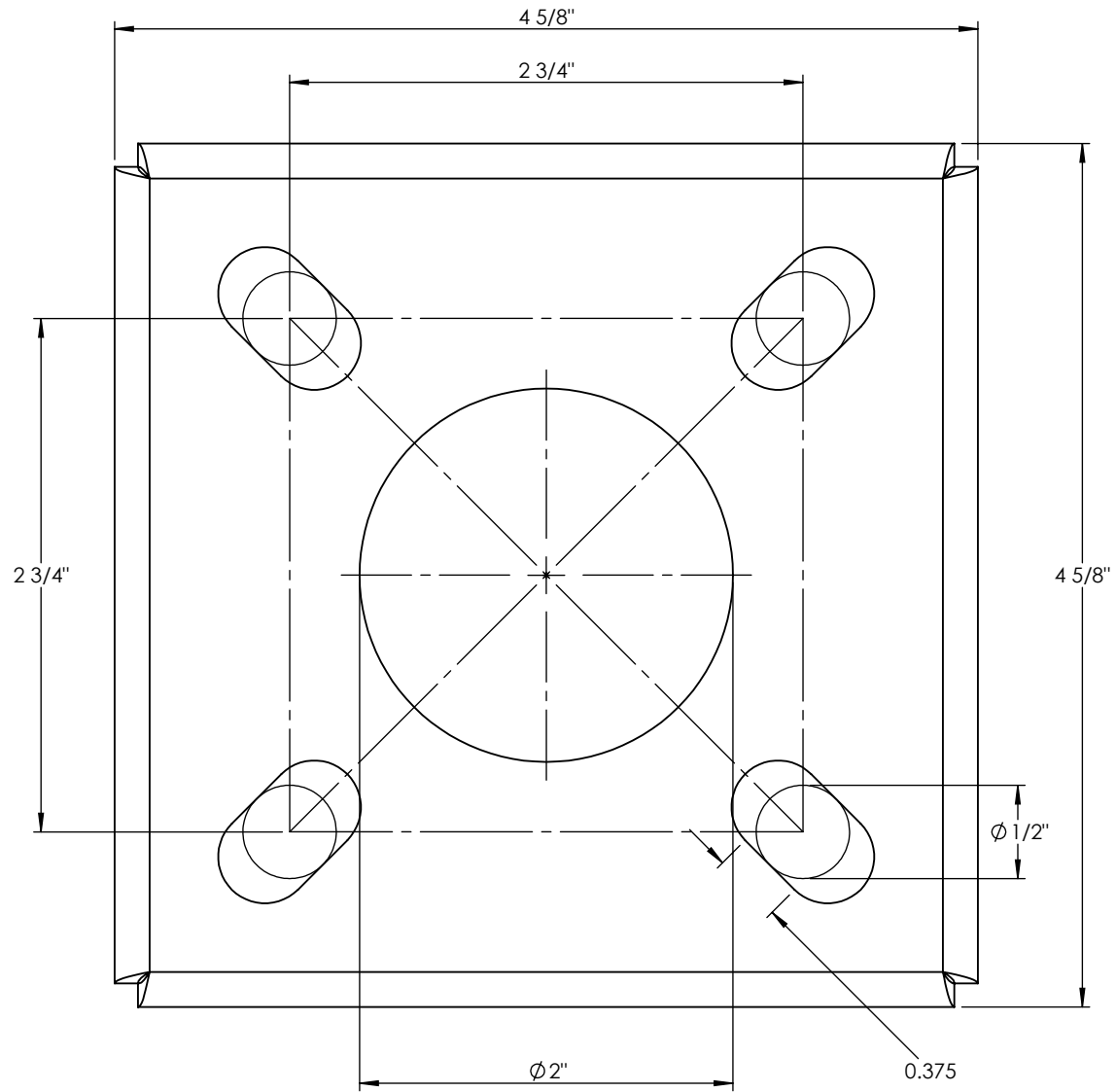

**3/8" X 12" LONG  
ANCHOR BOLT SIZE**