

ITEM NO.	PART NUMBER	DESCRIPTION	QTY.	CUT
1	EC-BX-CAV-20W-FRAME TUBE	5"X5" ALUMINUM POST	1	
2	EC-BX-CAV-20W-ANCHOR PLATE	ALUMINUM 0.125" PLATE	1	
3	EC-BX-CAV-20W-TOP PLATE	ALUMINUM 0.125" PLATE	1	
4	EC-BX-CAV-20W-OPEN SPACE SIDE PLATE	ALUMINUM 0.125" PLATE	1	
5	EC-BX-CAV-20W-TOP PLATE BRACKET	ALUMINUM 00635"	1	
6	EC-BX-CAV-20W-FRAME PLATE BRACKET	ALUMINUM 0.0635"	1	
7	EC-BX-CAV-20W-LED PLATE	ALUMINUM 0.0635"	1	
8	EC-BX-CAV-20W-DRIVER BRACKET	ALUMINUM 0.0635"	1	
9	EC-BX-CAV-20W-ACRYLIC	ACRYLIC	1	
10	TALLX20W HEXAGON HEAT SINK	HEAT SINK	1	
11	ESPEL29070MVH-1	DRIVER	1	
12	AITAILLED_PCN_D2000-20W	LED	1	

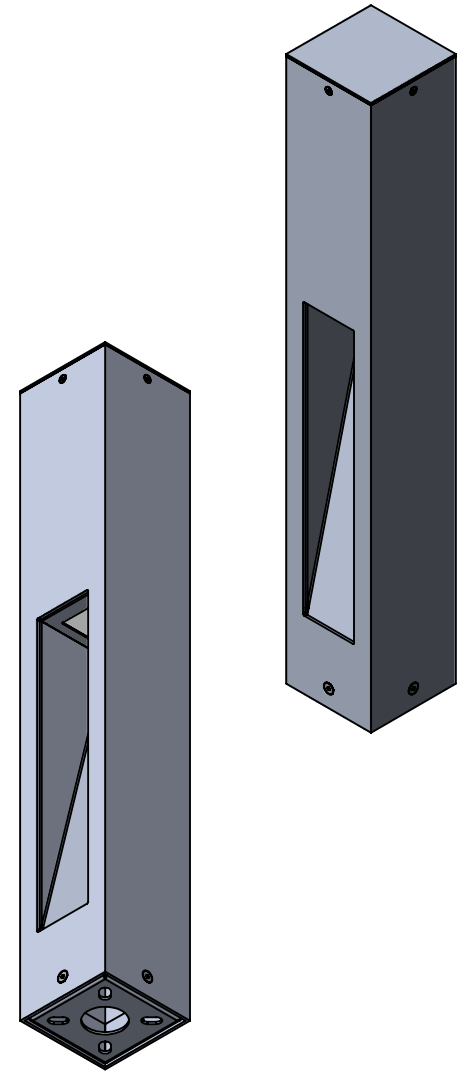
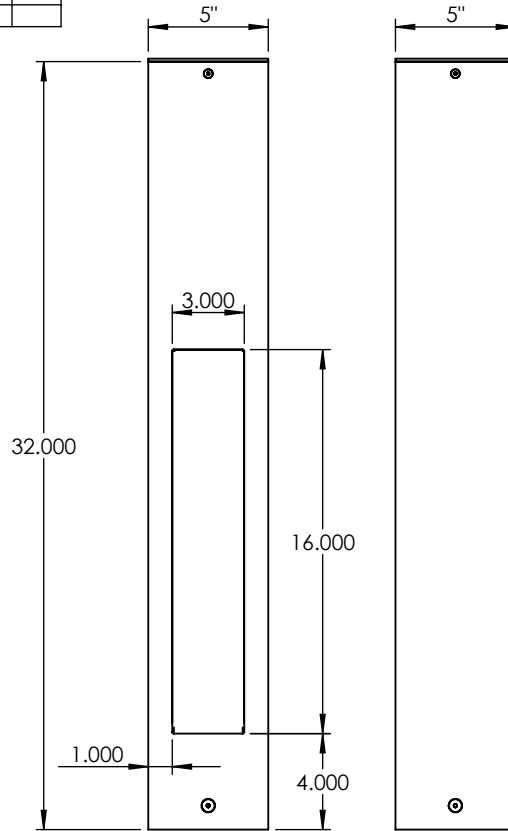
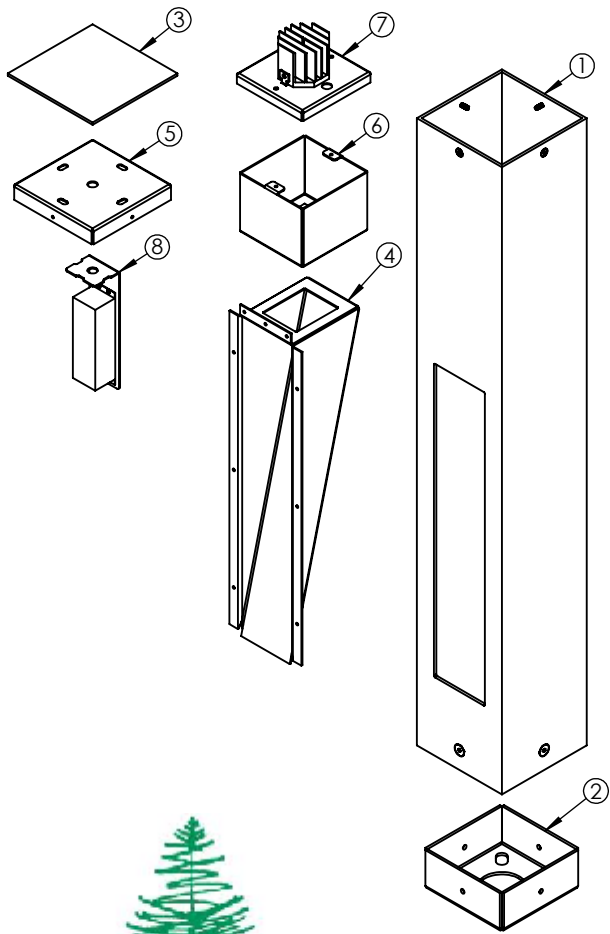

ALL BEND RADIUS .030"

UNLESS OTHERWISE SPECIFIED:

DIMENSIONS ARE IN INCHES
TOLERANCES:
FRACTIONAL ± .003
ANGULAR: MACH ±.01 BEND ±
TWO PLACE DECIMAL ±
THREE PLACE DECIMAL ±.001

INTERPRET GEOMETRIC
TOLERANCING PER:

MATERIAL

FINISH

DRAWN

CHECKED

ENG APPR.

MFG APPR.

Q.A.

COMMENTS:

NAME

DATE

TITLE:

EC-BX-CAV-20W

SIZE DWG. NO.

REV

A

SCALE: 1:8 WEIGHT:

SHEET 1 OF 9

APPLICATION

DO NOT SCALE DRAWING

5

4

3

2

1

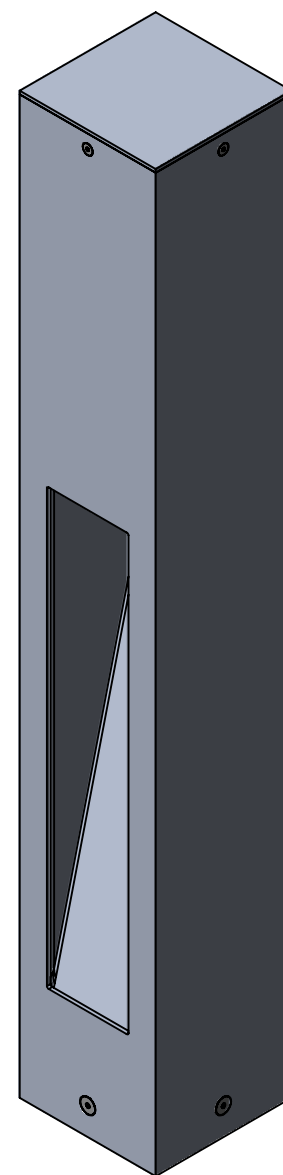
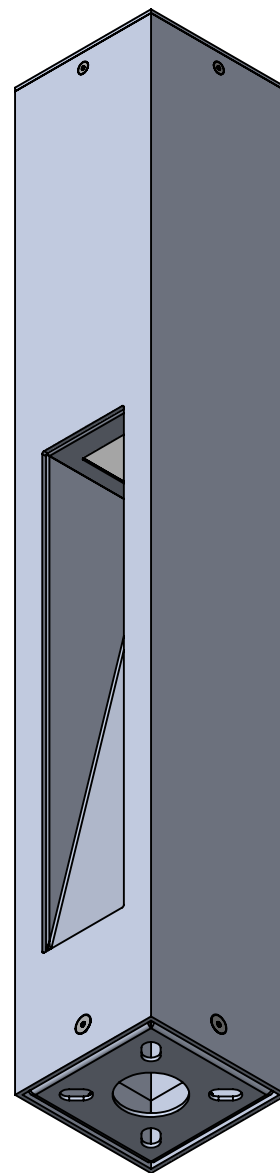
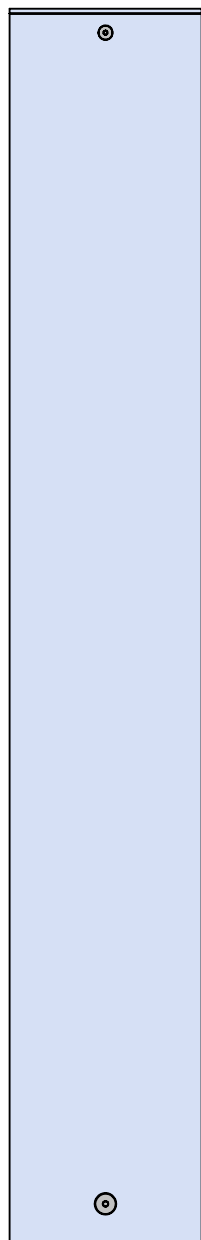
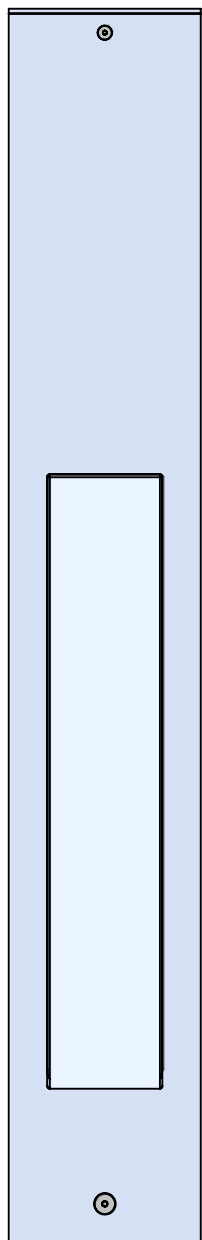

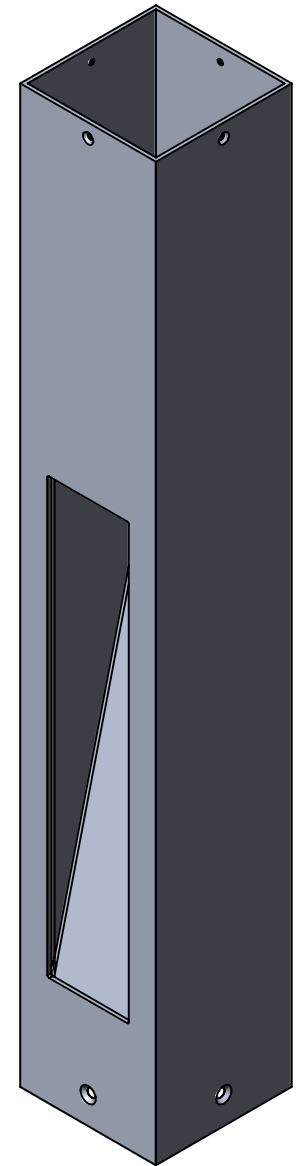
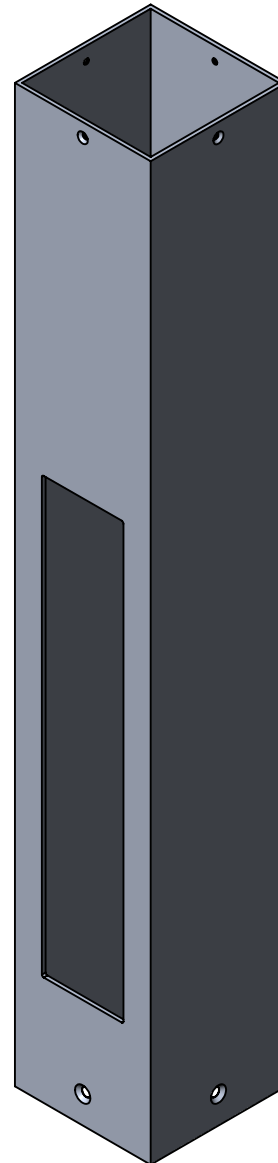
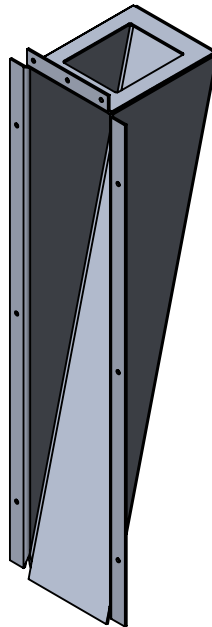
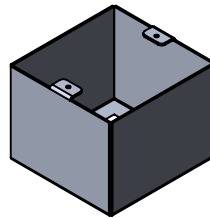
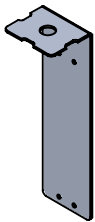
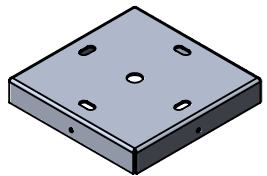
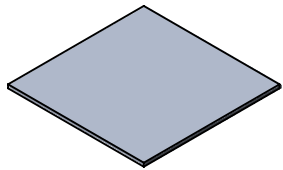
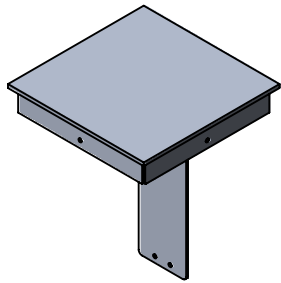

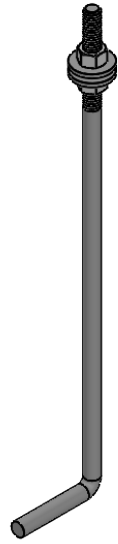
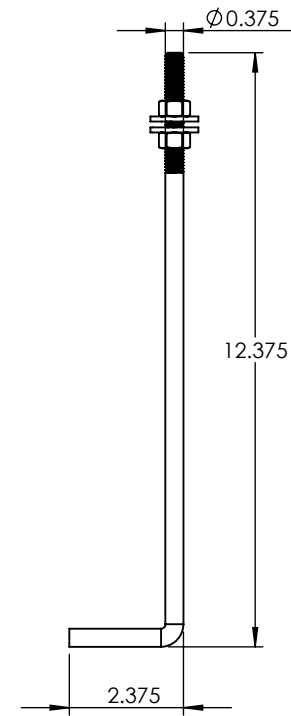
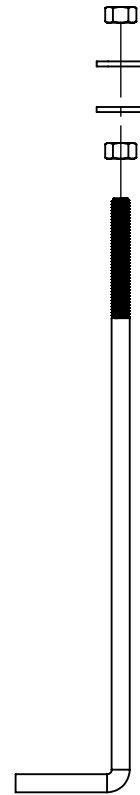
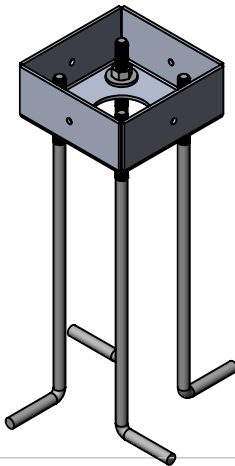
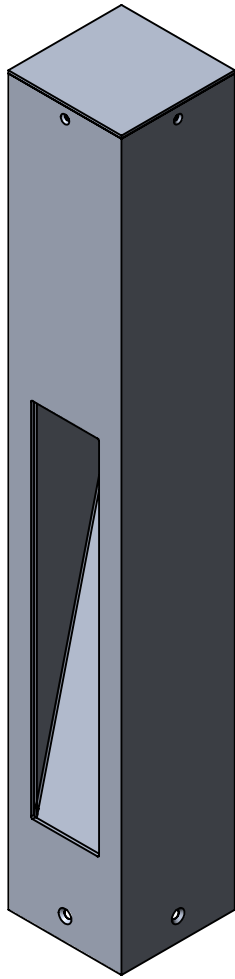

**3/8" X 12" LONG
ANCHOR BOLT SIZE**

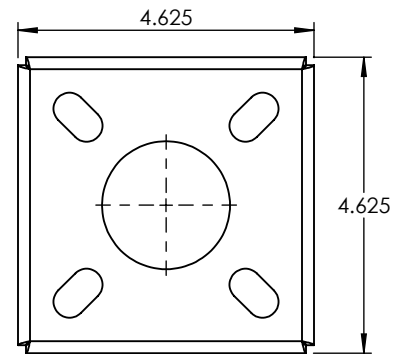
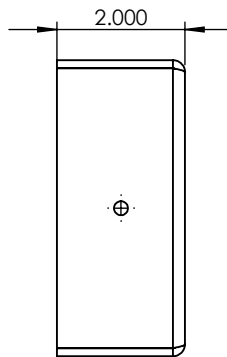
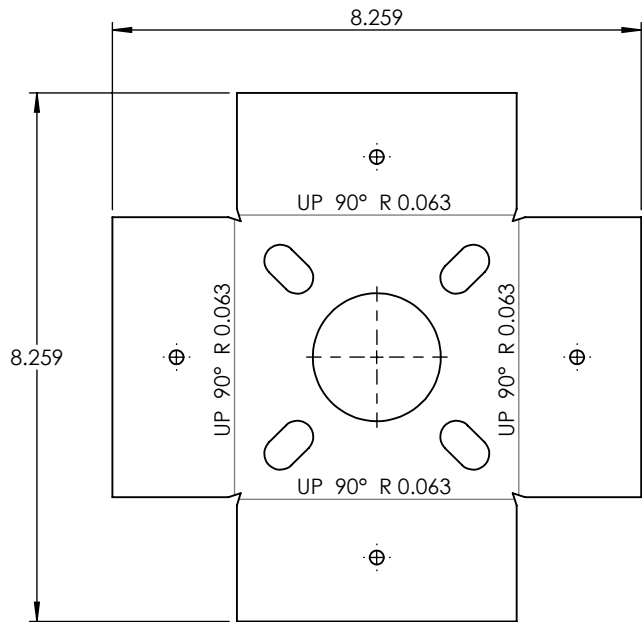
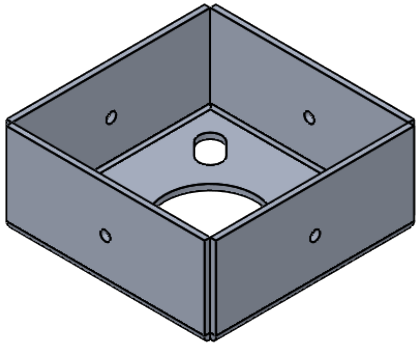

PROPRIETARY AND CONFIDENTIAL
 THE INFORMATION CONTAINED IN THIS DRAWING IS THE SOLE PROPERTY OF <INSERT COMPANY NAME HERE>. ANY REPRODUCTION IN PART OR AS A WHOLE WITHOUT THE WRITTEN PERMISSION OF <INSERT COMPANY NAME HERE> IS PROHIBITED.

		UNLESS OTHERWISE SPECIFIED:		NAME	DATE
		DIMENSIONS ARE IN INCHES	DRAWN		
		TOLERANCES:	CHECKED		
		FRACTIONAL ±	ENG APPR.		
		ANGULAR: MACH ± BEND ±	MFG APPR.		
		TWO PLACE DECIMAL ±	Q.A.		
		THREE PLACE DECIMAL ±	COMMENTS:		
		INTERPRET GEOMETRIC TOLERANCING PER:			
		MATERIAL			
NEXT ASSY	USED ON	FINISH			
APPLICATION		DO NOT SCALE DRAWING			

ALUMINUM 0.125" PLATE

TITLE:
 EC-BX-CAV-20W

SIZE	DWG. NO.	REV
A		
SCALE: 1:3	WEIGHT:	SHEET 5 OF 9

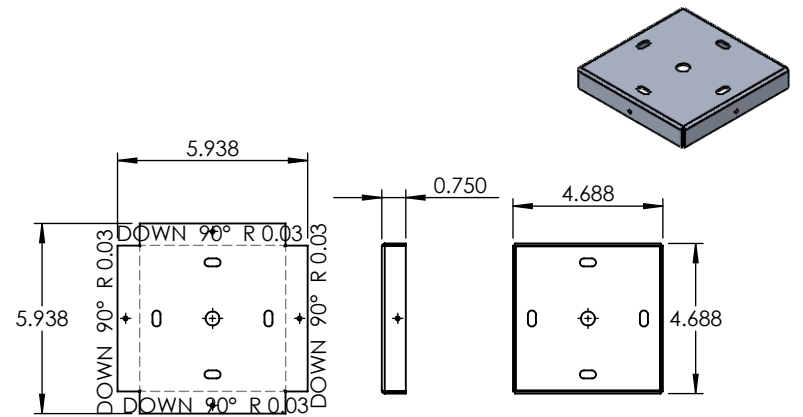
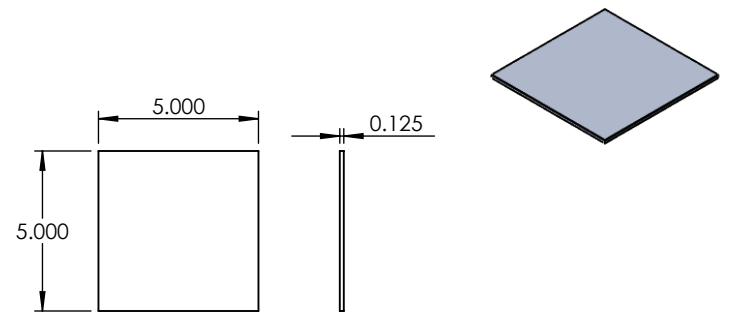
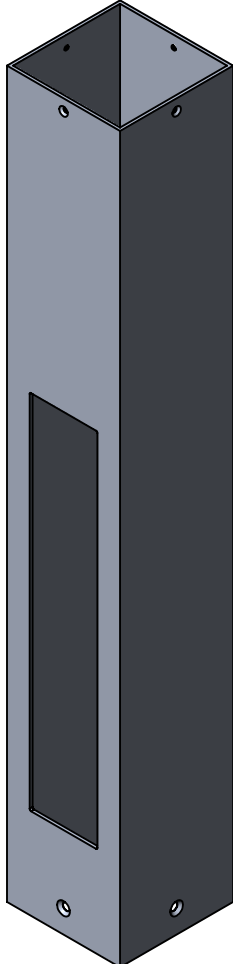
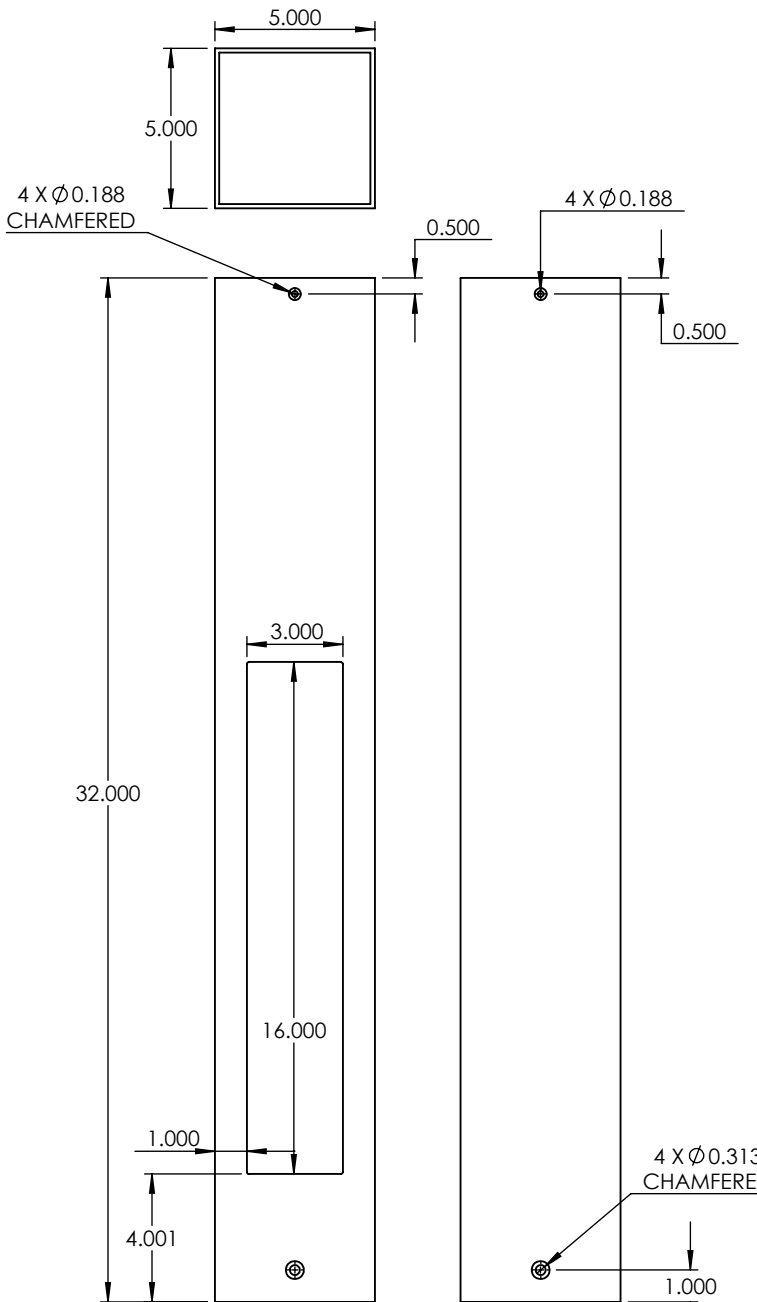

PROPRIETARY AND CONFIDENTIAL
 THE INFORMATION CONTAINED IN THIS DRAWING IS THE SOLE PROPERTY OF <INSERT COMPANY NAME HERE>. ANY REPRODUCTION IN PART OR AS A WHOLE WITHOUT THE WRITTEN PERMISSION OF <INSERT COMPANY NAME HERE> IS PROHIBITED.

NEXT ASSY	USED ON
APPLICATION	

UNLESS OTHERWISE SPECIFIED:	NAME	DATE
DIMENSIONS ARE IN INCHES	DRAWN	
TOLERANCES:	CHECKED	
FRACTIONAL ±	ENG APPR.	
ANGULAR: MACH ± BEND ±	MFG APPR.	
TWO PLACE DECIMAL ±	Q.A.	
THREE PLACE DECIMAL ±	COMMENTS:	
INTERPRET GEOMETRIC TOLERANCING PER:		
MATERIAL		
FINISH		
DO NOT SCALE DRAWING		

5"X5" ALUMINUM POST		
TITLE:		
EC-BX-CAV-20W		
SIZE	DWG. NO.	REV
A		
SCALE: 1:6	WEIGHT:	SHEET 6 OF 9

5

4

3

2

1

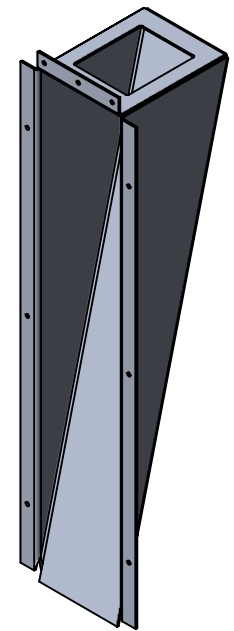
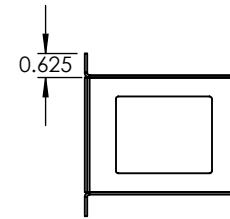
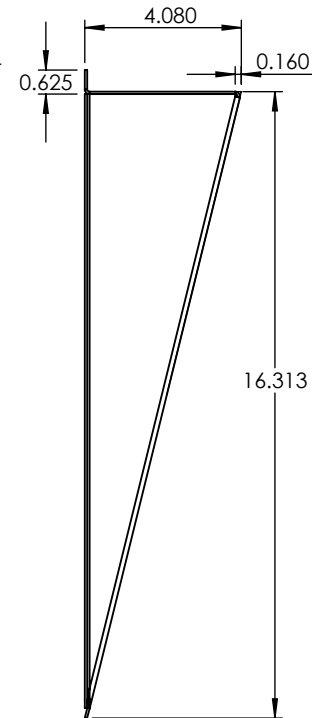
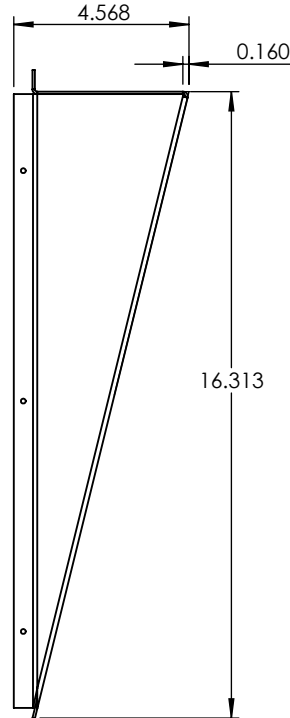
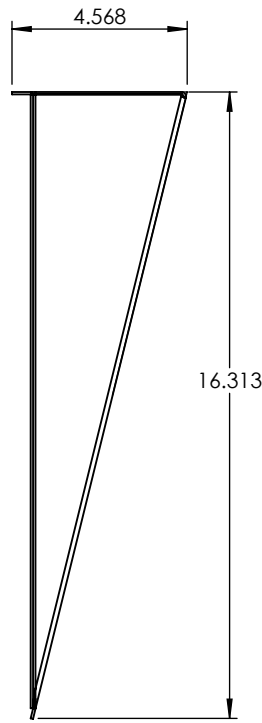
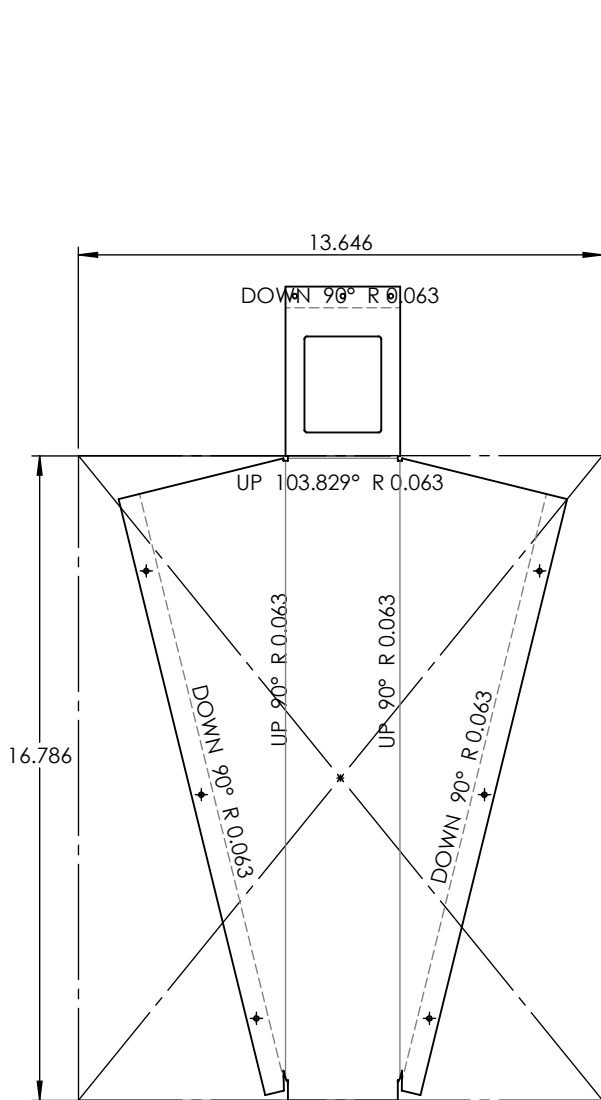

PROPRIETARY AND CONFIDENTIAL
 THE INFORMATION CONTAINED IN THIS DRAWING IS THE SOLE PROPERTY OF <INSERT COMPANY NAME HERE>. ANY REPRODUCTION IN PART OR AS A WHOLE WITHOUT THE WRITTEN PERMISSION OF <INSERT COMPANY NAME HERE> IS PROHIBITED.

NEXT ASSY	USED ON	FINISH
APPLICATION		DO NOT SCALE DRAWING

UNLESS OTHERWISE SPECIFIED:	NAME	DATE
DIMENSIONS ARE IN INCHES	DRAWN	
TOLERANCES:	CHECKED	
FRACTIONAL ±	ENG APPR.	
ANGULAR: MACH ± BEND ±	MFG APPR.	
TWO PLACE DECIMAL ±	Q.A.	
THREE PLACE DECIMAL ±	COMMENTS:	

ALUMINUM 0.125" PLATE		
TITLE:		
EC-BX-CAV-20W		
SIZE	DWG. NO.	REV
A		
SCALE: 1:5	WEIGHT:	SHEET 7 OF 9

5

4

3

2

1

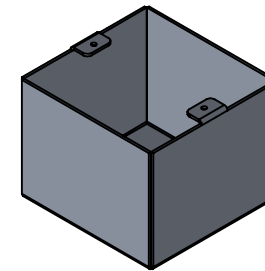
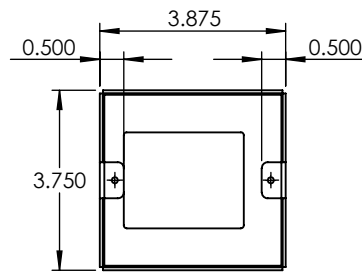
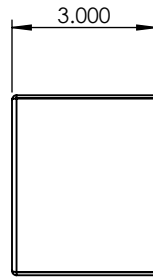
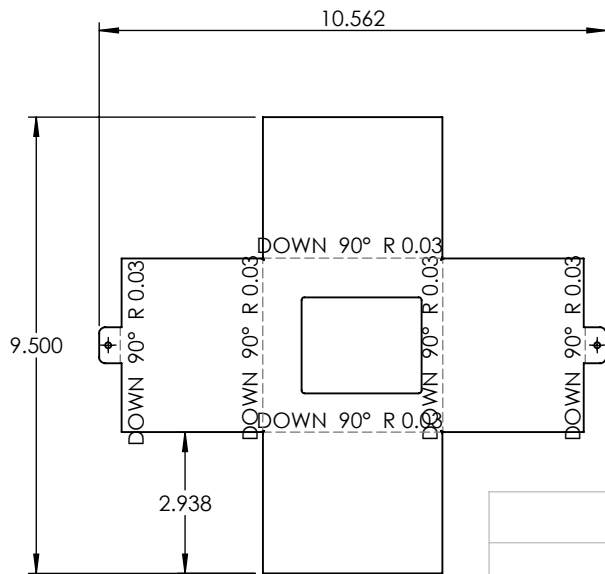
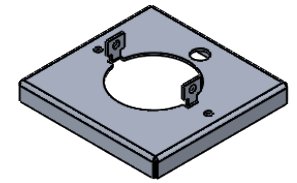
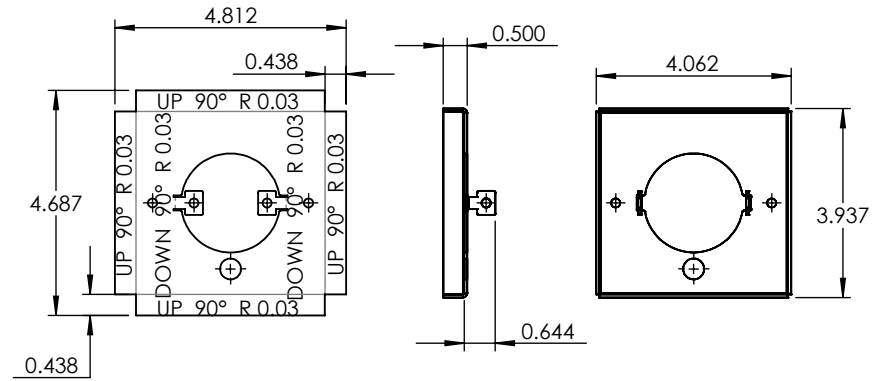
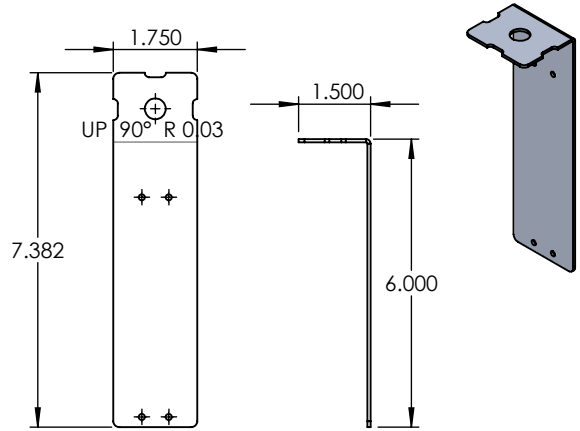

PROPRIETARY AND CONFIDENTIAL
 THE INFORMATION CONTAINED IN THIS DRAWING IS THE SOLE PROPERTY OF <INSERT COMPANY NAME HERE>. ANY REPRODUCTION IN PART OR AS A WHOLE WITHOUT THE WRITTEN PERMISSION OF <INSERT COMPANY NAME HERE> IS PROHIBITED.

		UNLESS OTHERWISE SPECIFIED:	NAME	DATE	ALUMINUM 0.0635"	
		DIMENSIONS ARE IN INCHES	DRAWN		TITLE:	
		TOLERANCES:	CHECKED		EC-BX-CAV-20W	
		FRACTIONAL ±	ENG APPR.		SIZE DWG. NO. REV	
		ANGULAR: MACH ± BEND ±	MFG APPR.		SCALE: 1:4 WEIGHT: SHEET 8 OF 9	
		TWO PLACE DECIMAL ±	Q.A.			
		THREE PLACE DECIMAL ±	COMMENTS:			
		INTERPRET GEOMETRIC TOLERANCING PER:				
		MATERIAL				
		FINISH				
NEXT ASSY	USED ON					
APPLICATION		DO NOT SCALE DRAWING				

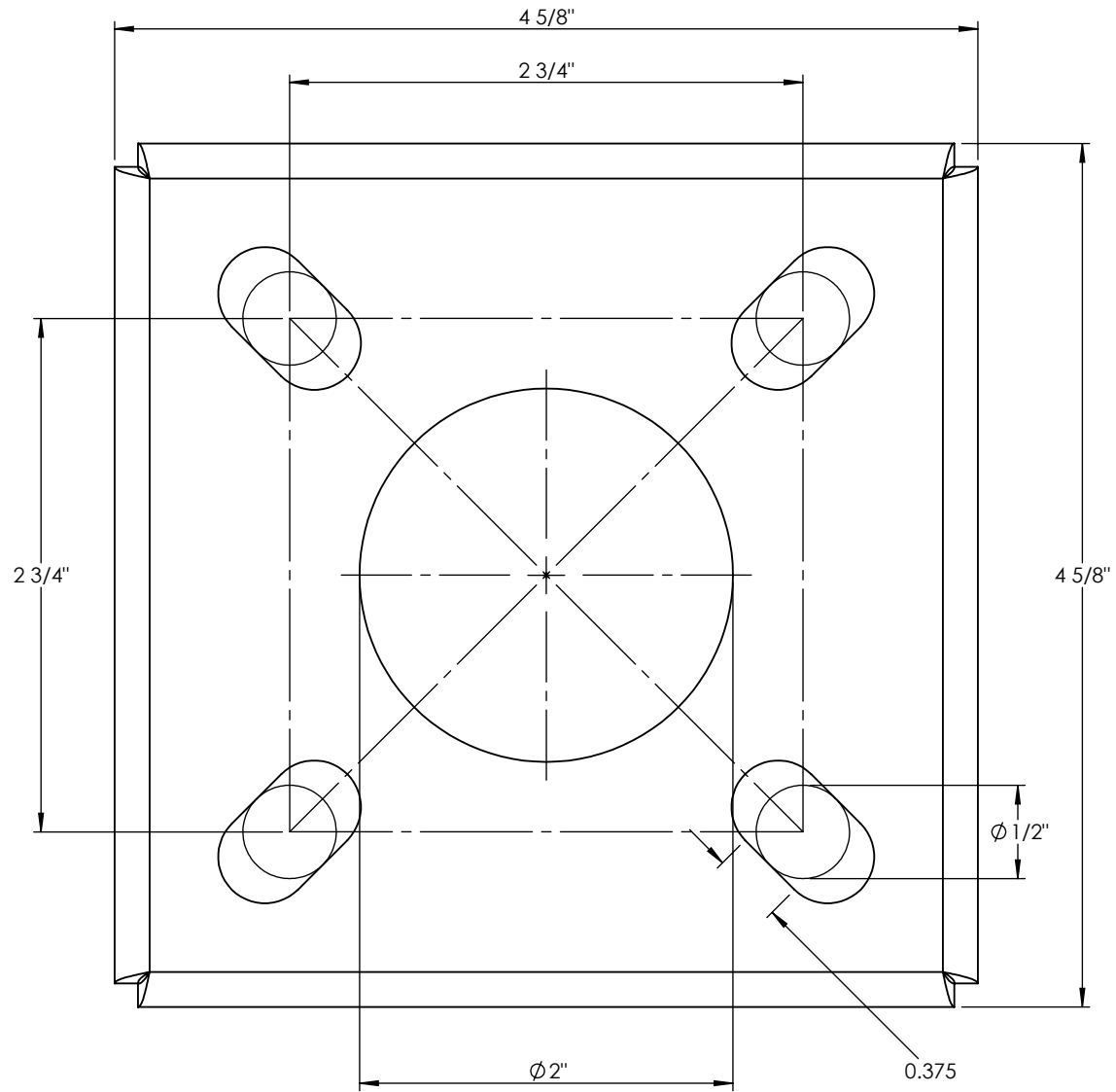

**3/8" X 12" LONG
ANCHOR BOLT SIZE**