

| ITEM NO. | PART NUMBER | DESCRIPTION | QTY. | CUT |
|----------|---|-----------------------|------|-----|
| 1 | EC-LM-BOL8X3-20W-ANCHOR PLATE | ALUMINUM 0.125" PLATE | 1 | |
| 2 | EC-LM-BOL8X3-20W-HEAD | ALUMINUM 0.125" PLATE | 1 | |
| 3 | EC-LM-BOL8X3-20W-HEAD-BOTTOM PLATE | ALUMINUM 0.125" PLATE | 1 | |
| 4 | EC-LM-BOL8X3-20W-LENS PLATE | ALUMINUM 0.125" PLATE | 1 | |
| 5 | LM-BOL8X3-40W-MBK-CA-40"-DIM-30K-VERTICAL REC TUBE BACK PLATE | ALUMINUM 0.125" PLATE | 2 | |
| 6 | EC-LM-BOL8X3-20W-VERTICAL REC TUBE SIDES PLATE | ALUMINUM 0.125" PLATE | 2 | |
| 7 | EC-LM-BOL8X3-20W-DOOR PLATE | ALUMINUM 0.125" PLATE | 1 | |
| 8 | EC-LM-BOL8X3-20W-DOOR BRACKET PLATE | ALUMINUM 0.0635" | 1 | |
| 9 | EC-LM-BOL8X3-20W-DRIVER BRACKET | ALUMINUM 0.0635" | 1 | |
| 10 | EC-LM-BOL8X3-20W-REGRESSED PLATE | ALUMINUM 0.0635" | 1 | |
| 11 | EC-LM-BOL8X3-20W-LED PLATE | ALUMINUM 0.0635" | 1 | |
| 12 | EC-LM-BOL8X3-20W-ACRYLIC | ACRYLIC | 1 | |
| 14 | Altgl_LED_PN1019_SHIM PLATE | ALUMINUM 0.125" PLATE | 2 | |
| 15 | ESPEN VEL29070MVH-1 | DRIVER | 1 | |
| 16 | Altgl_LED_PN1019_RevC | LED | 2 | |

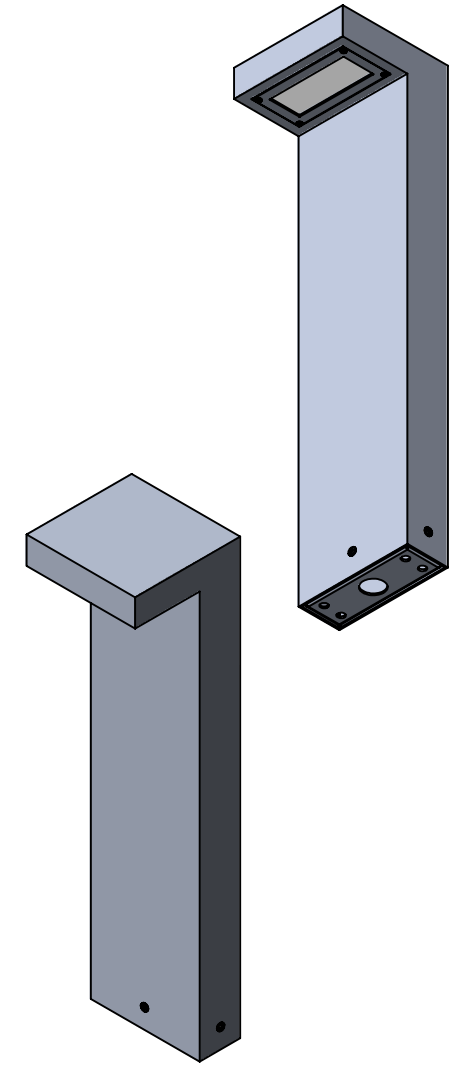
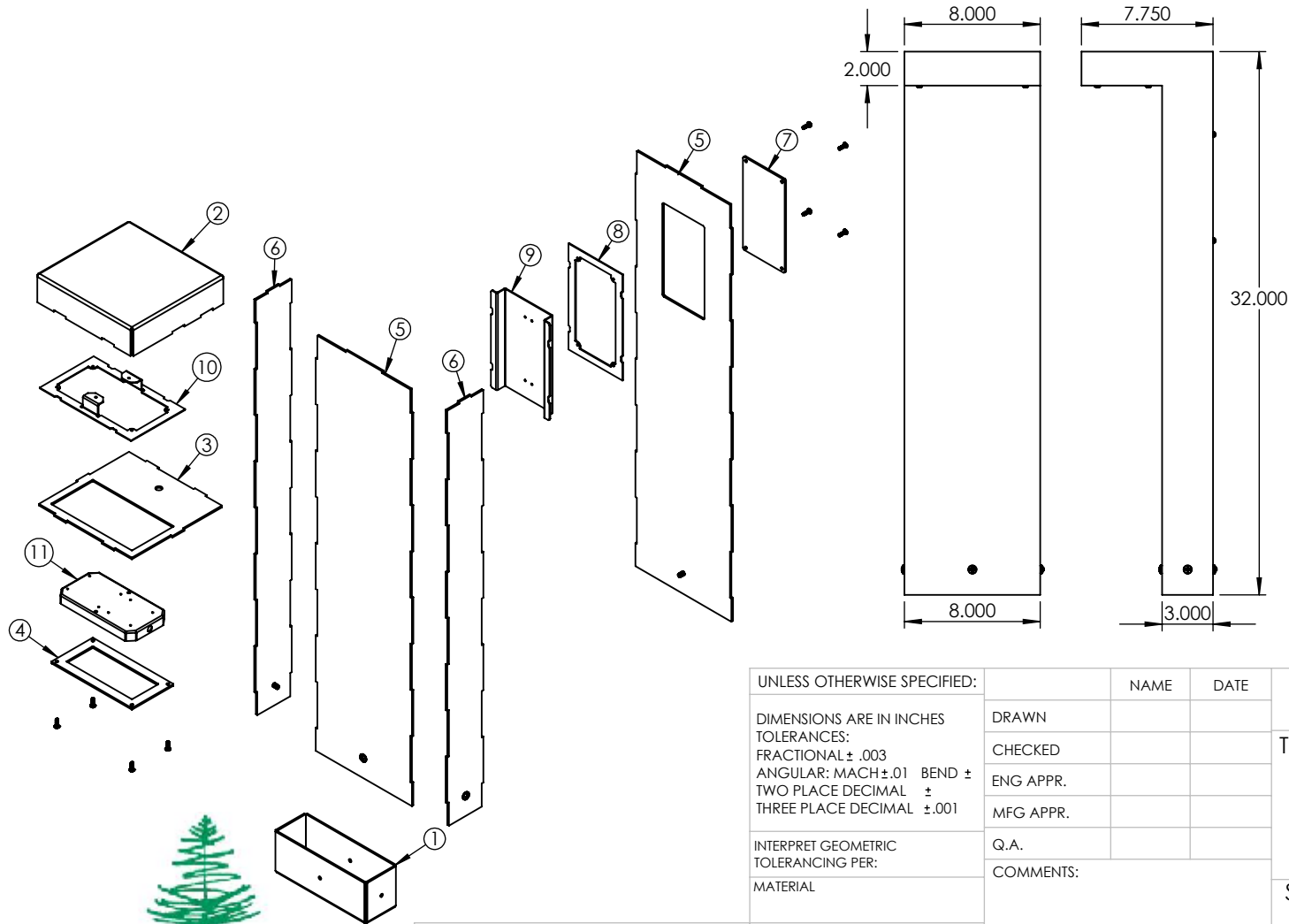

ALL BEND RADIUS .030"

| | | |
|--------------------------------------|-----------|------|
| UNLESS OTHERWISE SPECIFIED: | NAME | DATE |
| DIMENSIONS ARE IN INCHES | DRAWN | |
| TOLERANCES: | CHECKED | |
| FRACTIONAL ± .003 | ENG APPR. | |
| ANGULAR: MACH ± .01 BEND ± | MFG APPR. | |
| TWO PLACE DECIMAL ± | Q.A. | |
| THREE PLACE DECIMAL ±.001 | COMMENTS: | |
| INTERPRET GEOMETRIC TOLERANCING PER: | | |
| MATERIAL | | |
| FINISH | | |

| | | |
|------------------|----------|---------------|
| TITLE: | | |
| EC-LM-BOL8X3-20W | | |
| SIZE | DWG. NO. | REV |
| A | | |
| SCALE: 1:10 | WEIGHT: | SHEET 1 OF 10 |

5

4

3

2

1

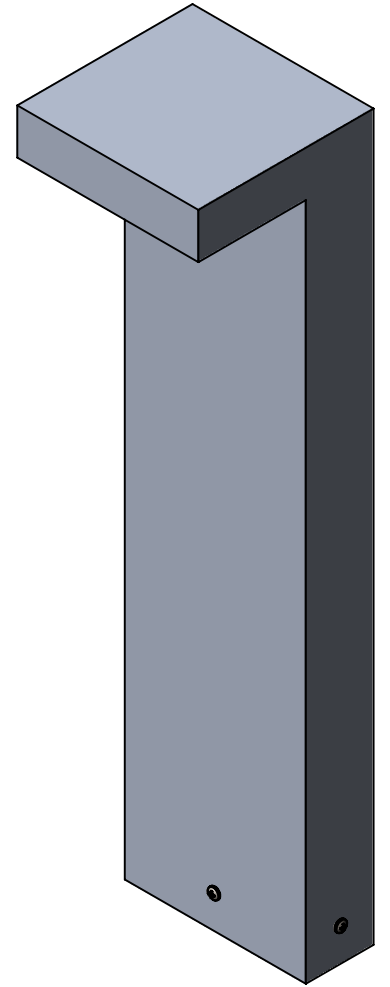
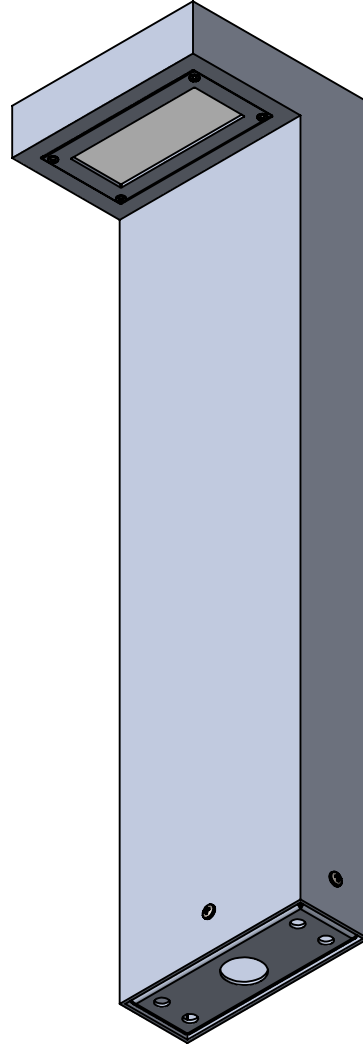
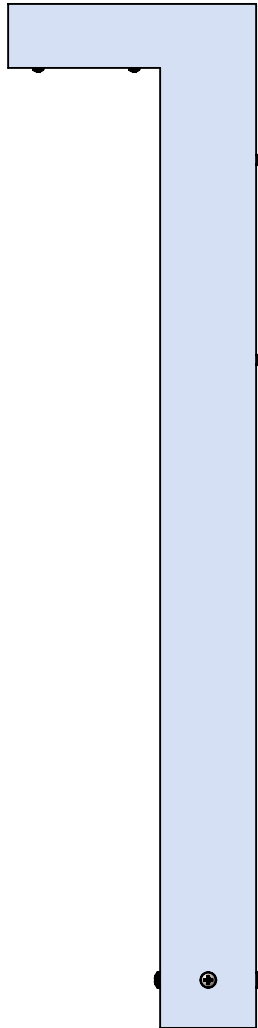
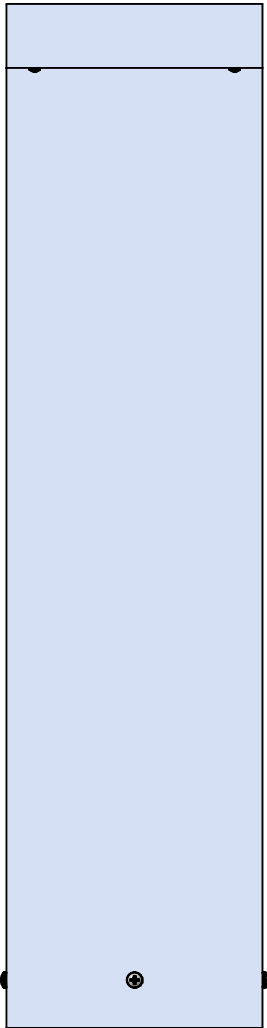
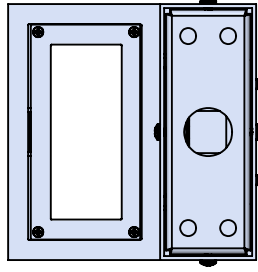
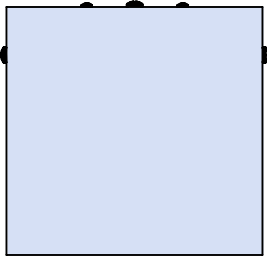

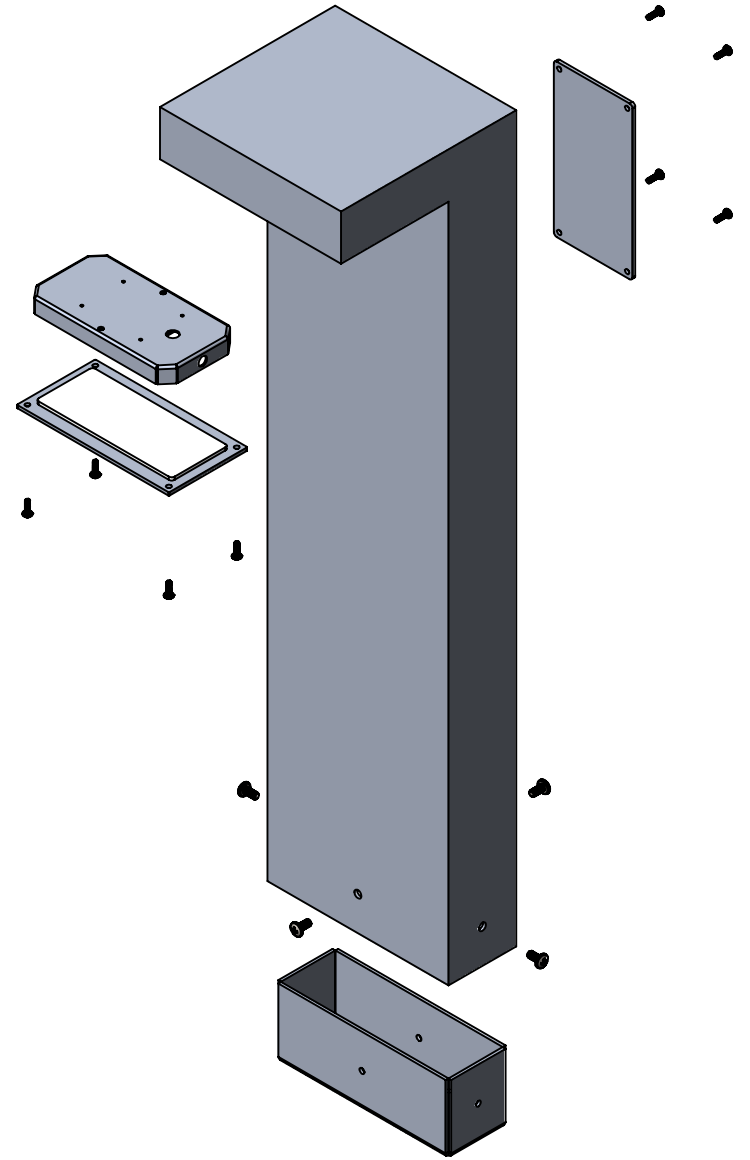
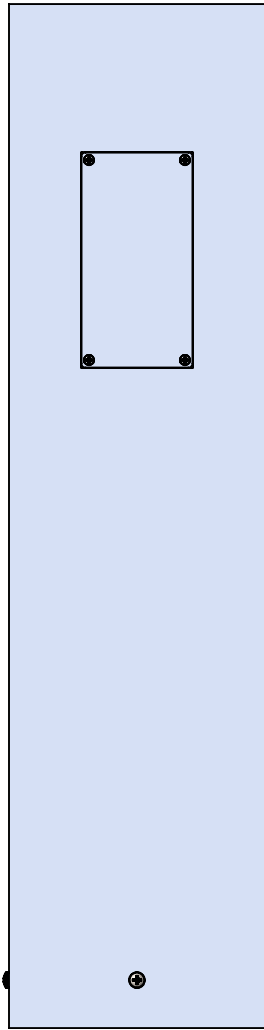
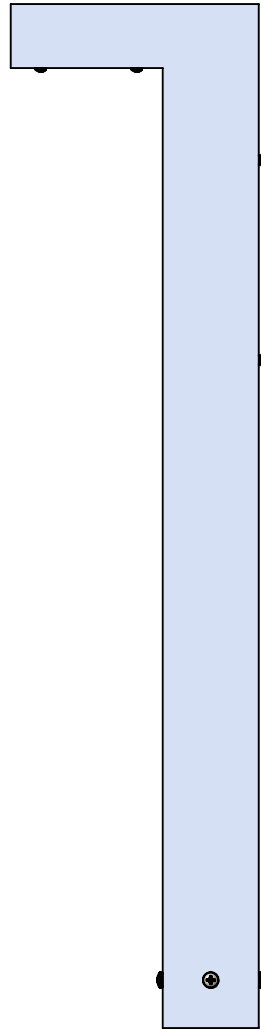
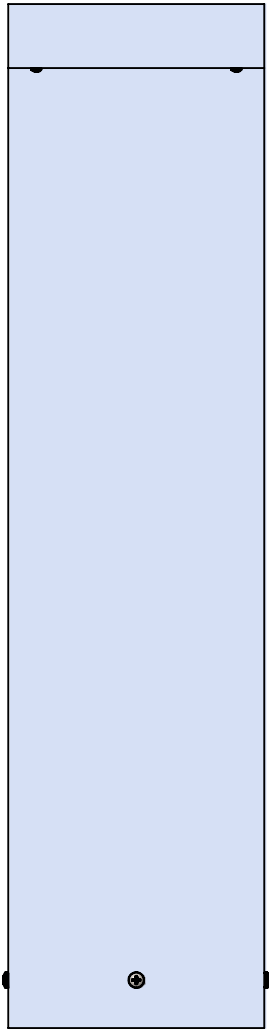

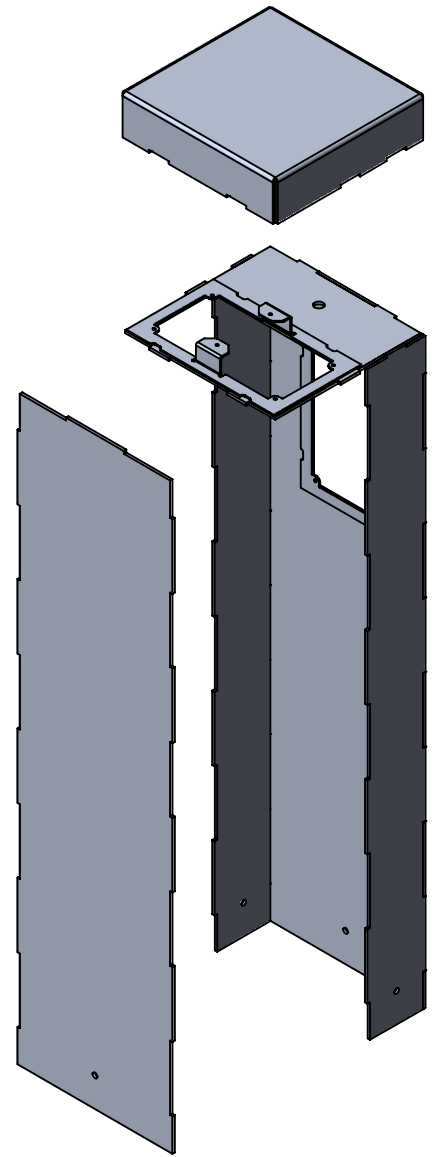
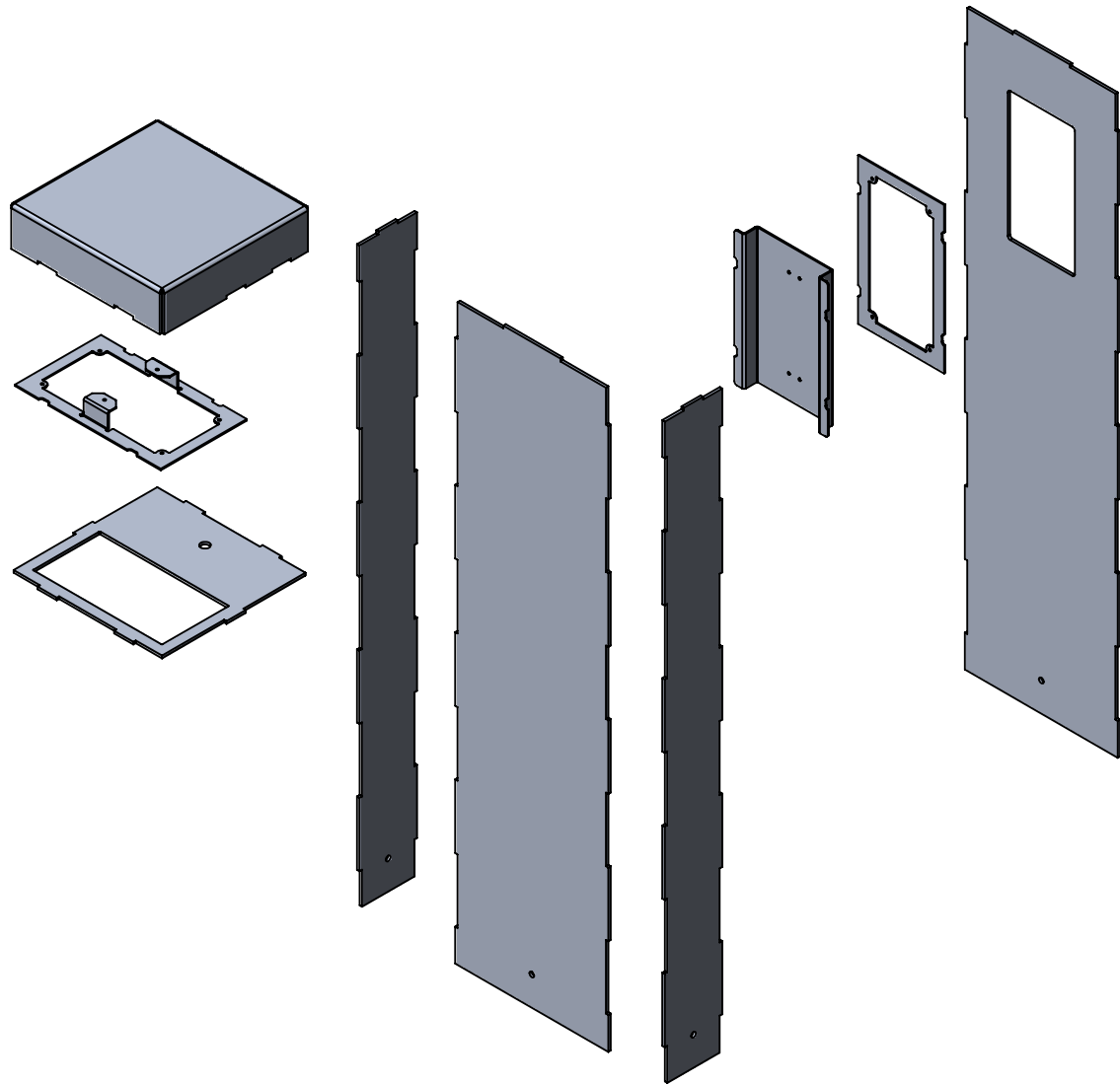

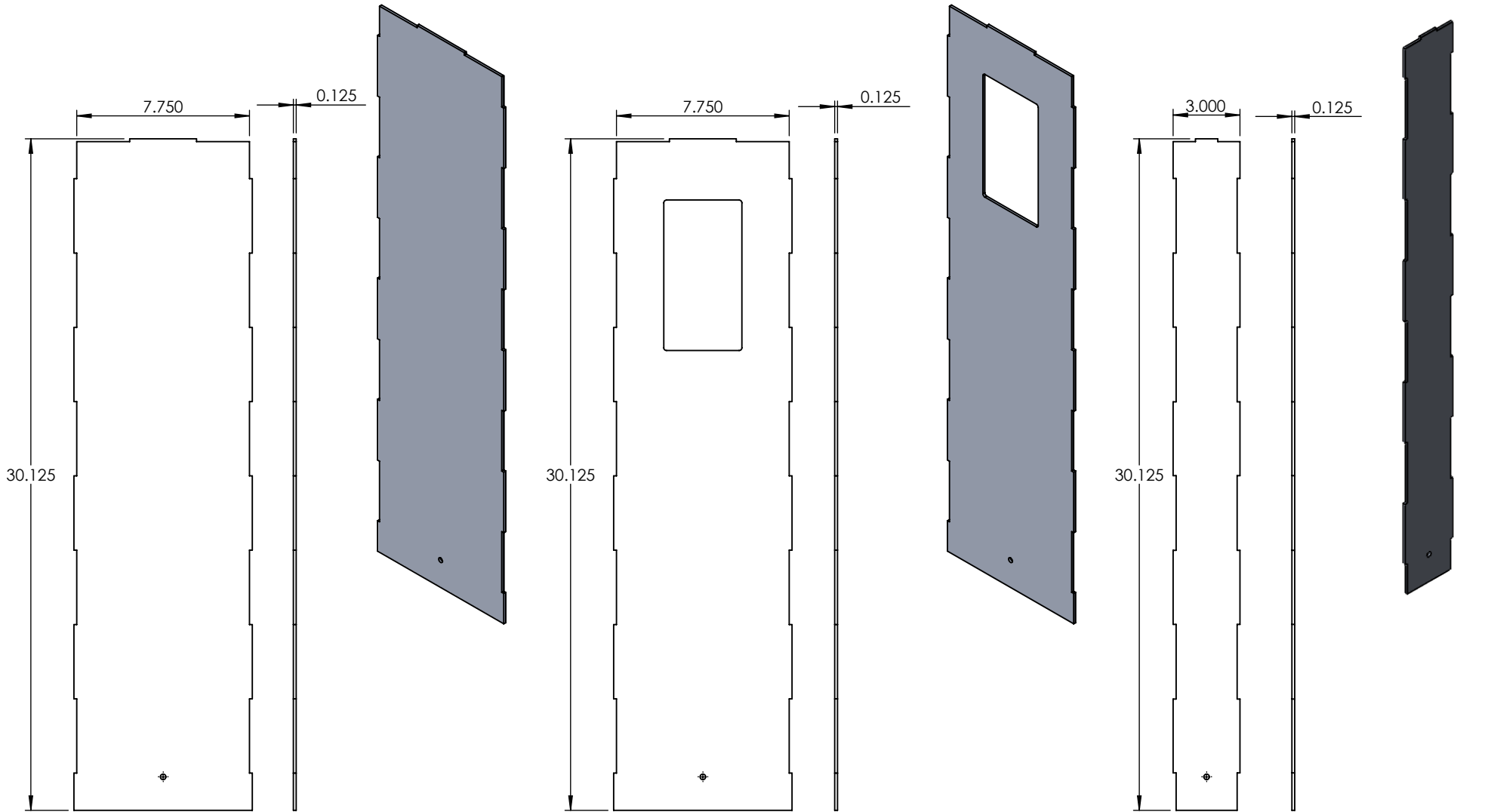

UNLESS OTHERWISE SPECIFIED:

DIMENSIONS ARE IN INCHES
 TOLERANCES:
 FRACTIONAL ±
 ANGULAR: MACH ± BEND ±
 TWO PLACE DECIMAL ±
 THREE PLACE DECIMAL ±

INTERPRET GEOMETRIC
 TOLERANCING PER:

MATERIAL

FINISH

DO NOT SCALE DRAWING

NAME DATE

8"x4" ALUMINUM TUBE 1/4" WALL THICKNESS

TITLE:

EC-LM-BOL8X3-20W

SIZE DWG. NO. REV

A

SCALE: 1:6.5 WEIGHT:

SHEET 5 OF 10

PROPRIETARY AND CONFIDENTIAL
 THE INFORMATION CONTAINED IN THIS
 DRAWING IS THE SOLE PROPERTY OF
 <INSERT COMPANY NAME HERE>. ANY
 REPRODUCTION IN PART OR AS A WHOLE
 WITHOUT THE WRITTEN PERMISSION OF
 <INSERT COMPANY NAME HERE> IS
 PROHIBITED.

NEXT ASSY

USED ON

APPLICATION

5

4

3

2

1

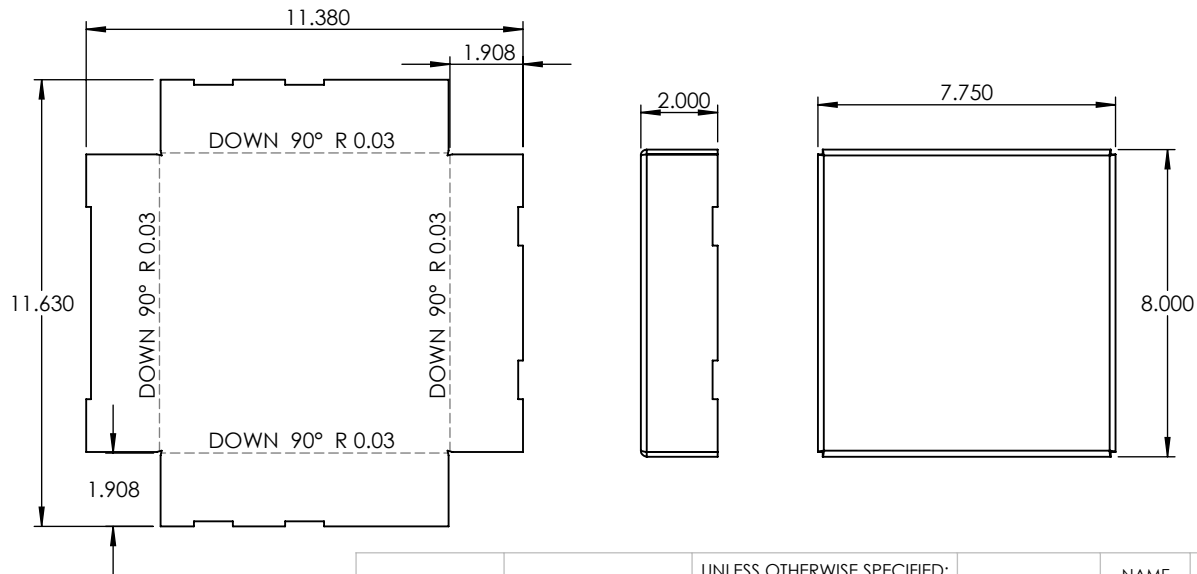
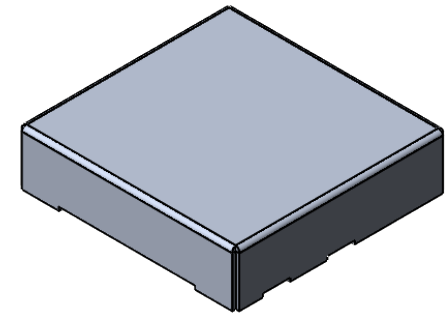
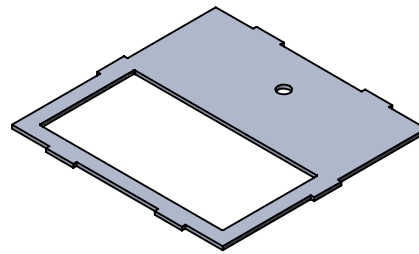
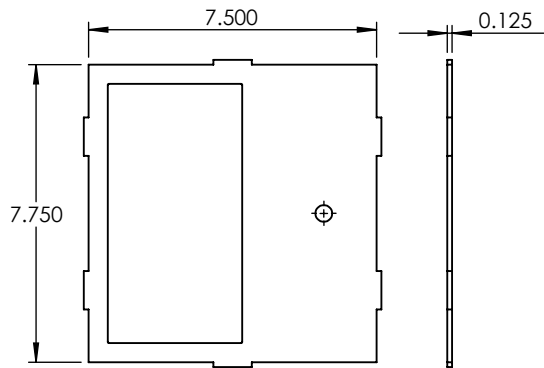

PROPRIETARY AND CONFIDENTIAL
 THE INFORMATION CONTAINED IN THIS DRAWING IS THE SOLE PROPERTY OF <INSERT COMPANY NAME HERE>. ANY REPRODUCTION IN PART OR AS A WHOLE WITHOUT THE WRITTEN PERMISSION OF <INSERT COMPANY NAME HERE> IS PROHIBITED.

| | | | | | |
|-------------|---------|--------------------------------------|-----------|------|------|
| | | UNLESS OTHERWISE SPECIFIED: | | NAME | DATE |
| | | DIMENSIONS ARE IN INCHES | DRAWN | | |
| | | TOLERANCES: | CHECKED | | |
| | | FRACTIONAL ± | ENG APPR. | | |
| | | ANGULAR: MACH ± BEND ± | MFG APPR. | | |
| | | TWO PLACE DECIMAL ± | Q.A. | | |
| | | THREE PLACE DECIMAL ± | COMMENTS: | | |
| | | INTERPRET GEOMETRIC TOLERANCING PER: | | | |
| | | MATERIAL | | | |
| NEXT ASSY | USED ON | FINISH | | | |
| APPLICATION | | DO NOT SCALE DRAWING | | | |

| | | |
|-----------------------|----------|---------------|
| ALUMINUM 0.125" PLATE | | |
| TITLE: | | |
| EC-LM-BOL8X3-20W | | |
| SIZE | DWG. NO. | REV |
| A | | |
| SCALE: 1:5 | WEIGHT: | SHEET 6 OF 10 |

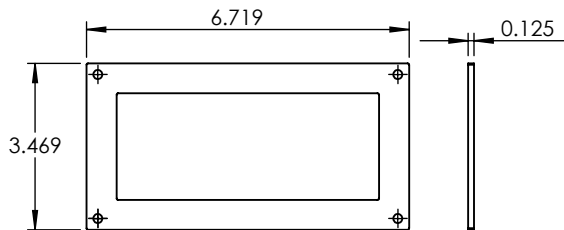
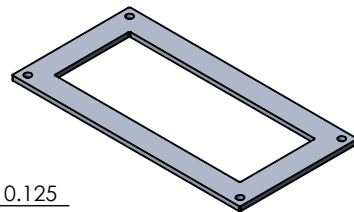
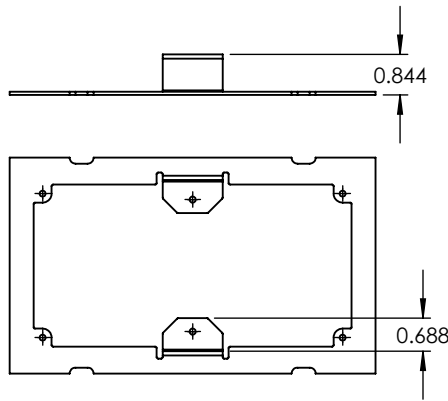
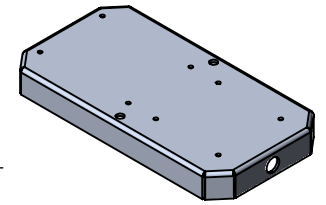
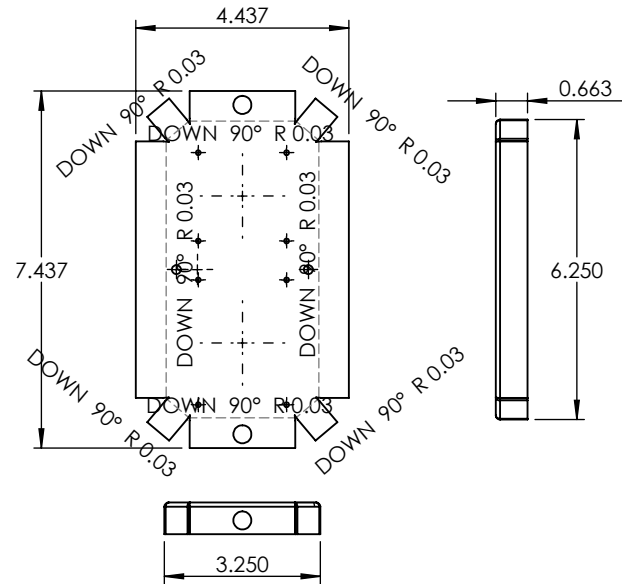
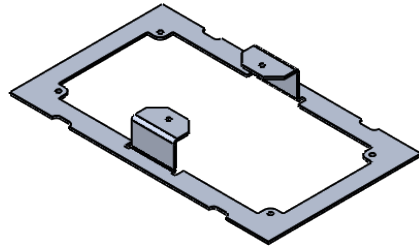
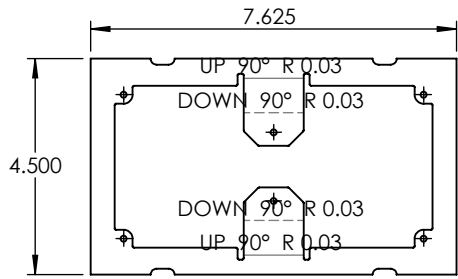

UNLESS OTHERWISE SPECIFIED:

DIMENSIONS ARE IN INCHES
 TOLERANCES:
 FRACTIONAL ±
 ANGULAR: MACH ± BEND ±
 TWO PLACE DECIMAL ±
 THREE PLACE DECIMAL ±

INTERPRET GEOMETRIC
 TOLERANCING PER:

MATERIAL

FINISH

DO NOT SCALE DRAWING

| | NAME | DATE |
|-----------|------|------|
| DRAWN | | |
| CHECKED | | |
| ENG APPR. | | |
| MFG APPR. | | |
| Q.A. | | |
| COMMENTS: | | |

ALUMINUM 0.0635"

TITLE:

EC-LM-BOL8X3-20W

| SIZE | DWG. NO. | REV |
|------------|----------|---------------|
| A | | |
| SCALE: 1:4 | WEIGHT: | SHEET 7 OF 10 |

PROPRIETARY AND CONFIDENTIAL
 THE INFORMATION CONTAINED IN THIS
 DRAWING IS THE SOLE PROPERTY OF
 <INSERT COMPANY NAME HERE>. ANY
 REPRODUCTION IN PART OR AS A WHOLE
 WITHOUT THE WRITTEN PERMISSION OF
 <INSERT COMPANY NAME HERE> IS
 PROHIBITED.

| NEXT ASSY | USED ON | APPLICATION |
|-----------|---------|-------------|
| | | |

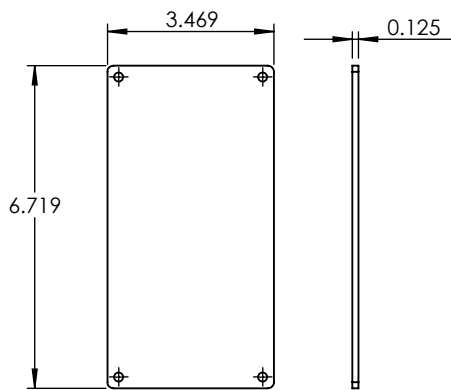
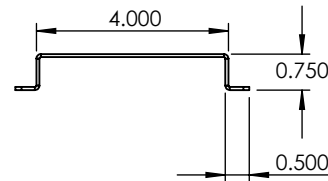
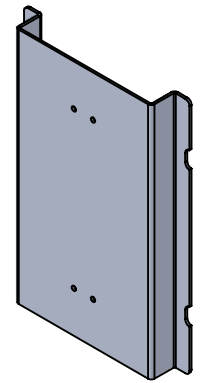
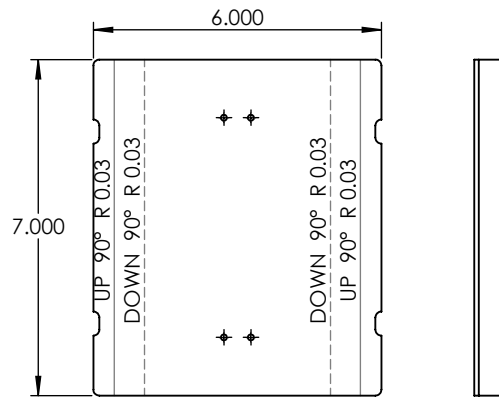
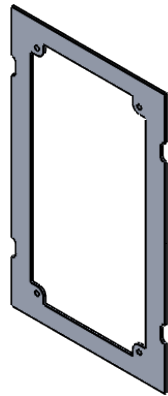
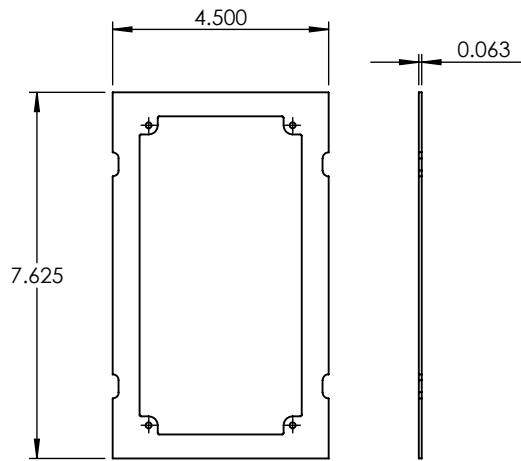

| | | | | | |
|--------------------------------------|--|----------------------|------|----------------------------------|--|
| UNLESS OTHERWISE SPECIFIED: | | NAME | DATE | ALUMINUM 0.0635" | |
| DIMENSIONS ARE IN INCHES | | DRAWN | | TITLE: EC-LM-BOL8X3-20W | |
| TOLERANCES: | | CHECKED | | | |
| FRACTIONAL ± | | ENG APPR. | | | |
| ANGULAR: MACH ± BEND ± | | MFG APPR. | | | |
| TWO PLACE DECIMAL ± | | Q.A. | | SIZE DWG. NO. REV | |
| THREE PLACE DECIMAL ± | | COMMENTS: | | SCALE: 1:4 WEIGHT: SHEET 8 OF 10 | |
| INTERPRET GEOMETRIC TOLERANCING PER: | | | | | |
| MATERIAL | | | | | |
| FINISH | | | | | |
| NEXT ASSY USED ON | | | | | |
| APPLICATION | | DO NOT SCALE DRAWING | | | |

PROPRIETARY AND CONFIDENTIAL
 THE INFORMATION CONTAINED IN THIS DRAWING IS THE SOLE PROPERTY OF <INSERT COMPANY NAME HERE>. ANY REPRODUCTION IN PART OR AS A WHOLE WITHOUT THE WRITTEN PERMISSION OF <INSERT COMPANY NAME HERE> IS PROHIBITED.

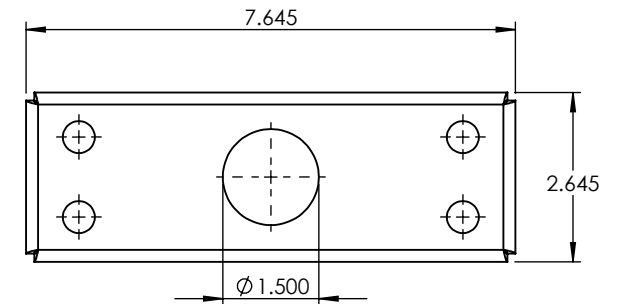
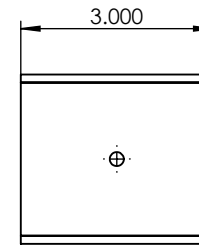
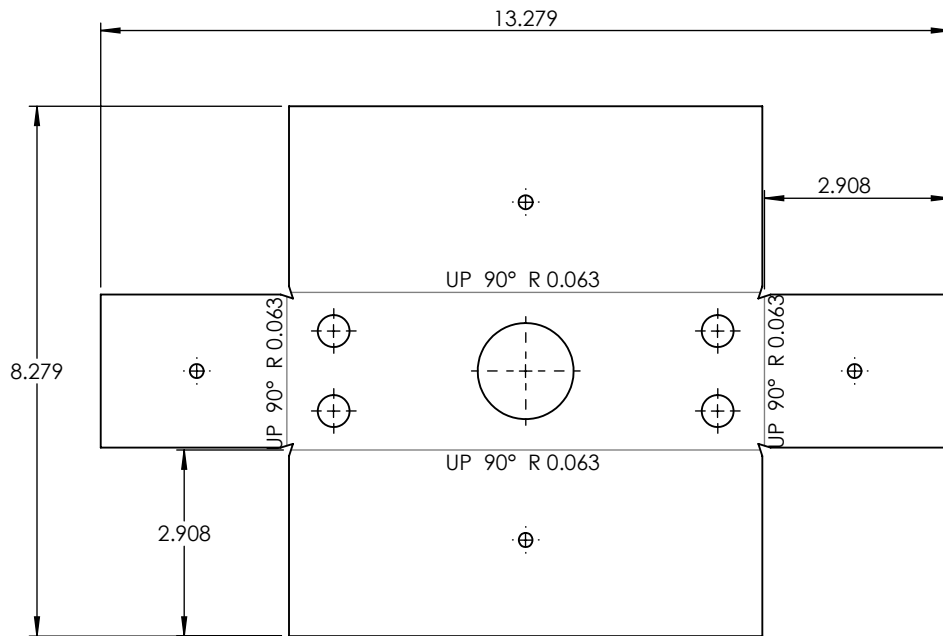
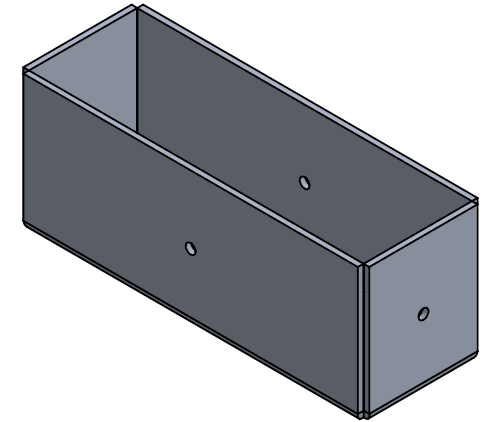
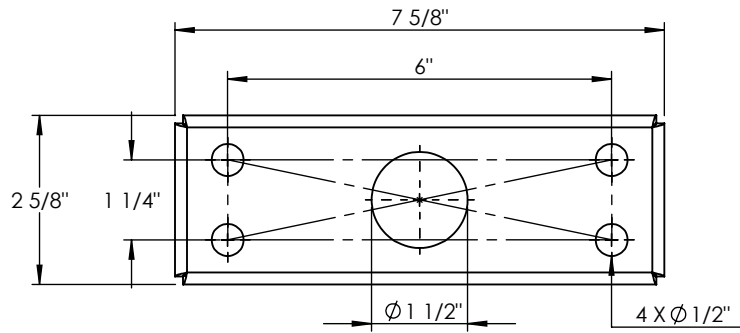

PROPRIETARY AND CONFIDENTIAL
 THE INFORMATION CONTAINED IN THIS DRAWING IS THE SOLE PROPERTY OF <INSERT COMPANY NAME HERE>. ANY REPRODUCTION IN PART OR AS A WHOLE WITHOUT THE WRITTEN PERMISSION OF <INSERT COMPANY NAME HERE> IS PROHIBITED.

| | | | | | |
|-------------|---------|--------------------------------------|-----------|------|------|
| | | UNLESS OTHERWISE SPECIFIED: | | NAME | DATE |
| | | DIMENSIONS ARE IN INCHES | DRAWN | | |
| | | TOLERANCES: | CHECKED | | |
| | | FRACTIONAL ± | ENG APPR. | | |
| | | ANGULAR: MACH ± BEND ± | MFG APPR. | | |
| | | TWO PLACE DECIMAL ± | Q.A. | | |
| | | THREE PLACE DECIMAL ± | COMMENTS: | | |
| | | INTERPRET GEOMETRIC TOLERANCING PER: | | | |
| | | MATERIAL | | | |
| NEXT ASSY | USED ON | FINISH | | | |
| APPLICATION | | DO NOT SCALE DRAWING | | | |

ALUMINUM 0.125" PLATE

TITLE:

EC-LM-BOL8X3-20W

| | | |
|------------|----------|---------------|
| SIZE | DWG. NO. | REV |
| A | | |
| SCALE: 1:3 | WEIGHT: | SHEET 9 OF 10 |

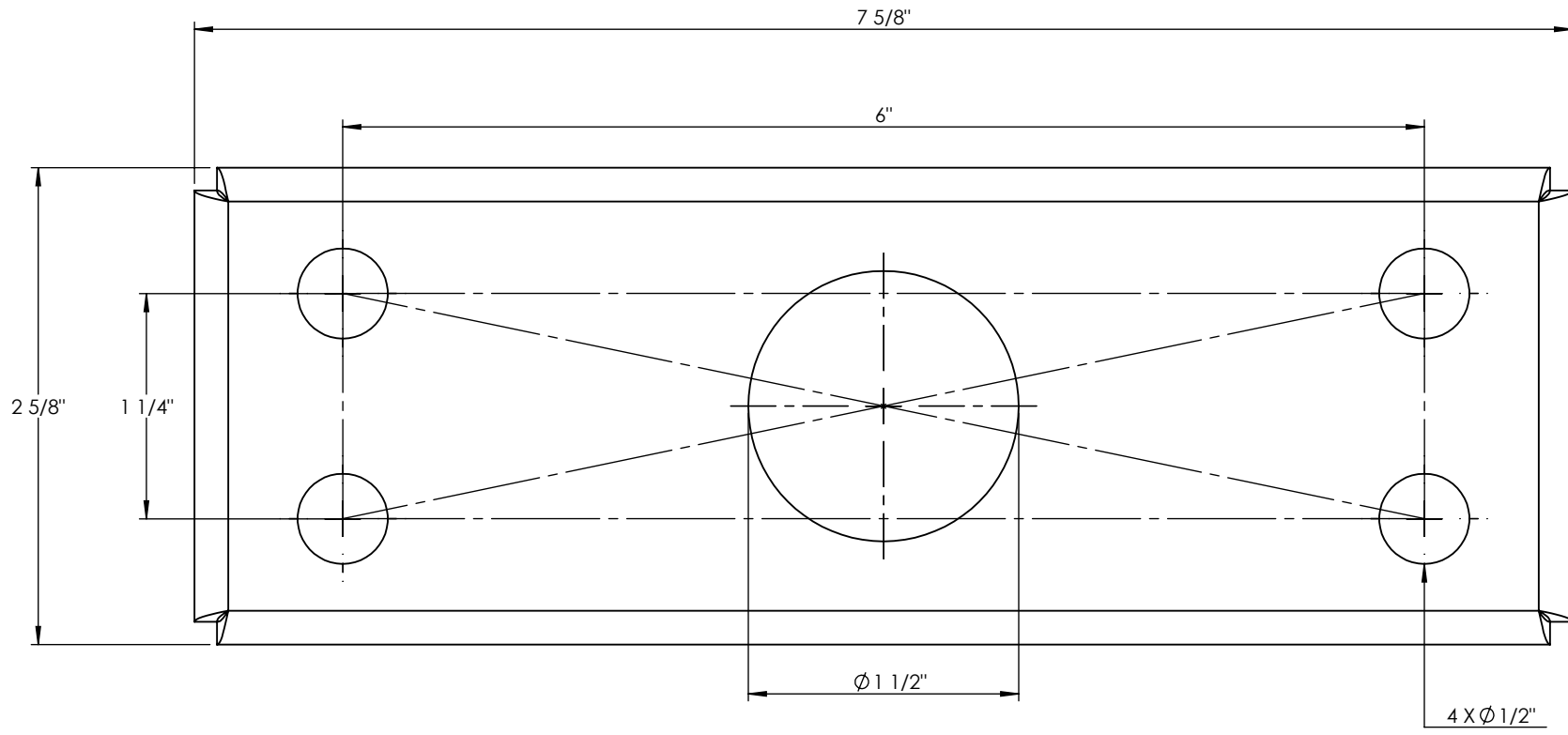

**3/16" X 12" LONG
ANCHOR BOLT SIZE**