

ITEM NO.	PART NUMBER	DESCRIPTION	QTY.	CUT
1	EC-STR-B-32-12W-9-CF-CYLINDER TUBE	5" CYLINDER TUBE	1	
2	EC-STR-B-32-12W-9-CF-ANCHOR PLATE TAB	ALUMINUM 0.500" PLATE	4	
3	EC-STR-B-32-12W-9-CF-ANCHOR PLATE	ALUMINUM 0.500" PLATE	1	
4	EC-STR-B-32-12W-9-CF-LED PLATE	ALUMINUM 0.125" PLATE	1	
5	EC-STR-B-32-12W-9-CF-SPUN TOP CAP	SPUN ALUMINUM 0.080"	1	
6	EC-STR-B-32-12W-9-CF-TUBE SLEEVE	SPUN ALUMINUM 0.080"	1	
7	EC-STR-B-32-12W-9-CF-SPUN CONE SEAT	SPUN ALUMINUM 0.080"	1	
8	EC-STR-B-32-12W-9-CF-SPUN LENS CAP	SPUN ALUMINUM 0.080"	2	
9	EC-STR-B-32-12W-9-CF-REFLECTOR LOUVER	SPUN ALUMINUM 0.0635"	6	
10	EC-STR-B-32-12W-9-CF-TUBE BRACKET	ALUMINUM 0.0635"	1	
11	EC-STR-B-32-12W-9-CF-DRIVER BRACKET	ALUMINUM 0.0635"	1	
12	EC-STR-B-32-12W-9-CF-REFLECTOR SUPPORT	1/4" THREADED ROD	4	
13	EC-STR-B-32-12W-9-CF-0.375" REFLECTOR SPACER	3/8" ALUMINUM CYLINDER	28	
14	EC-STR-B-32-12W-9-CF-SQUARE TUBE	1" SQUARE ALUMINUM TUBE	1	
15	EC-STR-B-32-12W-9-CF-3" LENS	ACRYLIC	1	
16	8-32 SS Hex Drive Flat Head	8-32 FLAT HEAD SCREW	4	
17	Espen VEL19070MVH-1	DRIVER	1	
18	Alttailed PN1012 RevD	LED	4	

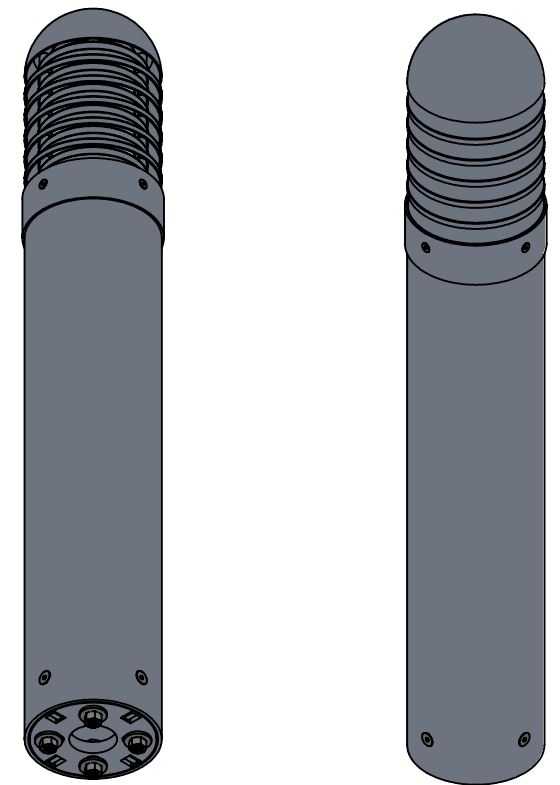
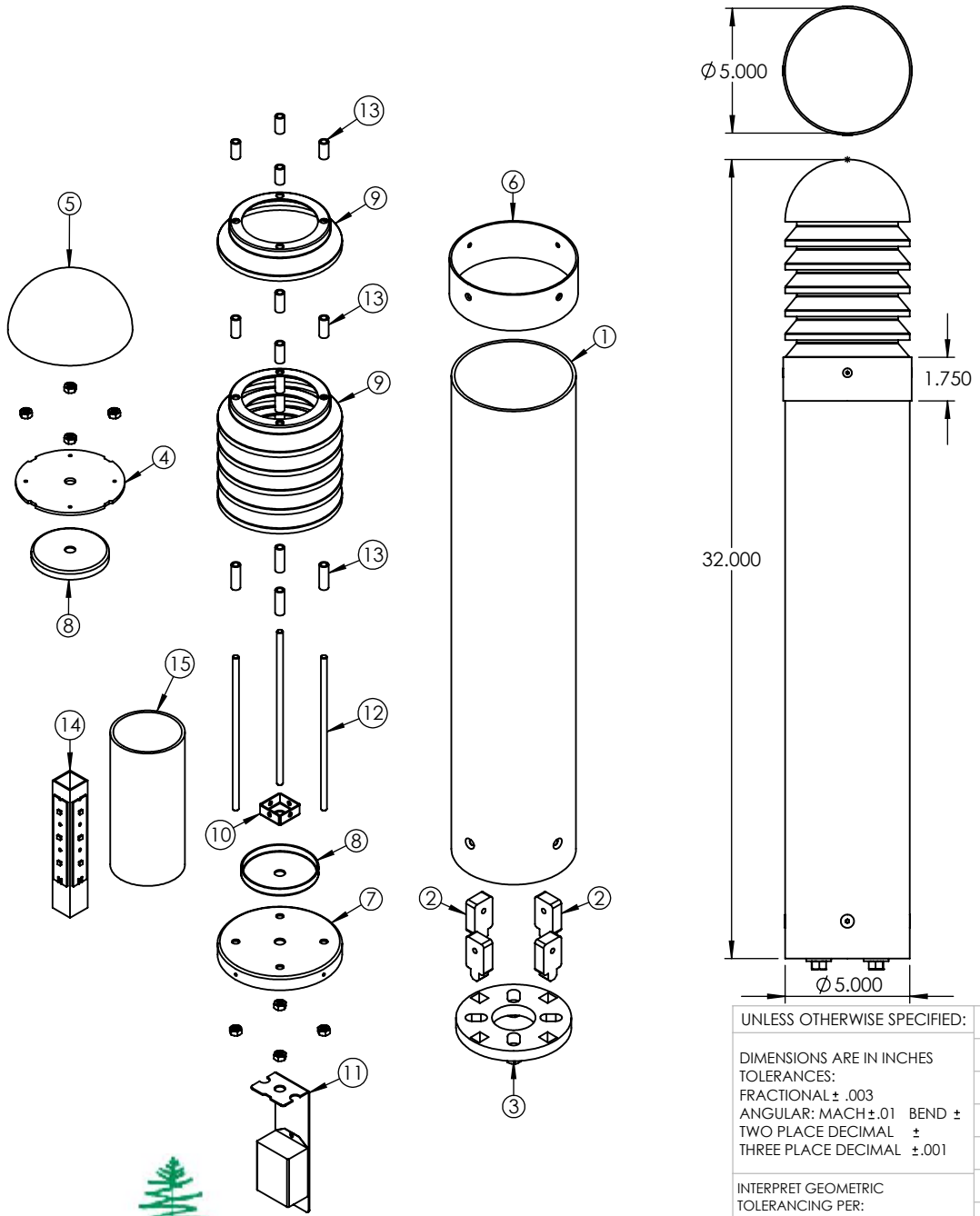

UNLESS OTHERWISE SPECIFIED:

DIMENSIONS ARE IN INCHES
TOLERANCES:
FRACTIONAL ± .003
ANGULAR: MACH ± .01 BEND ±
TWO PLACE DECIMAL ±
THREE PLACE DECIMAL ±.001

INTERPRET GEOMETRIC
TOLERANCING PER:

MATERIAL

FINISH

APPLICATION

DO NOT SCALE DRAWING

	NAME	DATE
DRAWN		
CHECKED		
ENG APPR.		
MFG APPR.		
Q.A.		
COMMENTS:		

TITLE:		
EC-STR-B-32-12W-9-CF		
SIZE	DWG. NO.	REV
A		
SCALE: 1:7	WEIGHT:	SHEET 1 OF 18



5

4

3

2

1

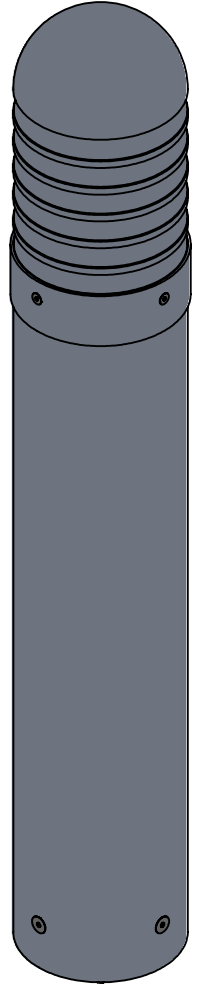
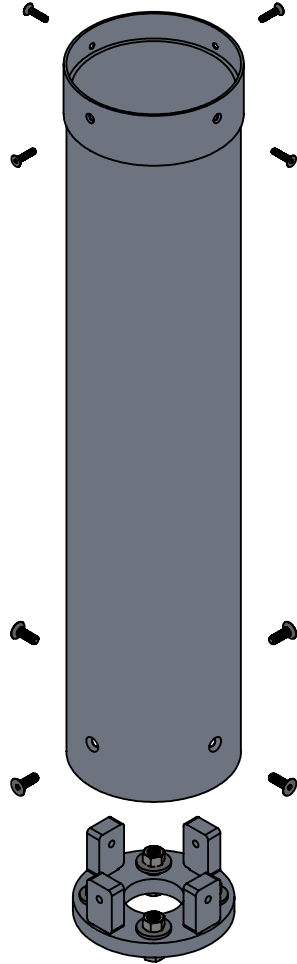
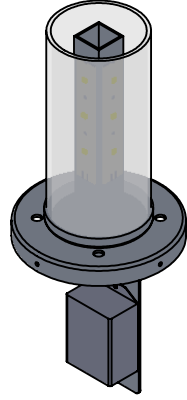
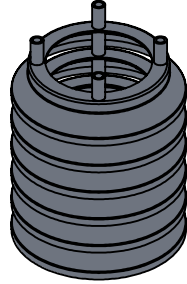
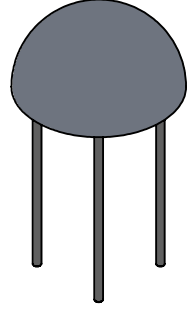
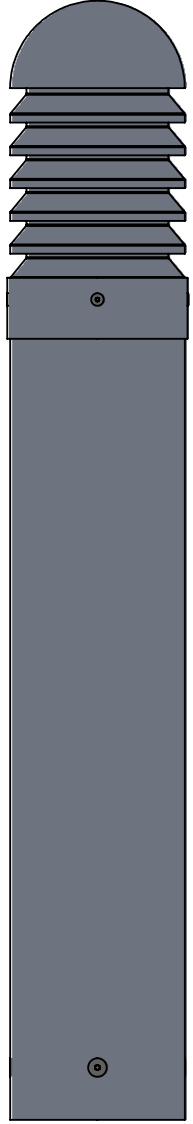
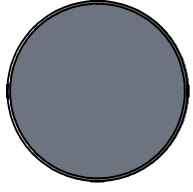

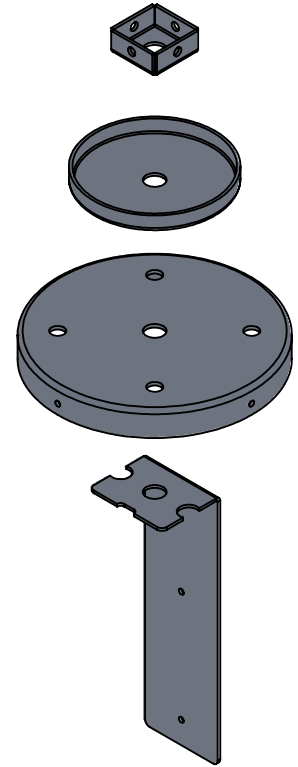
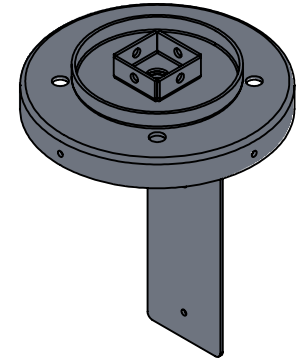
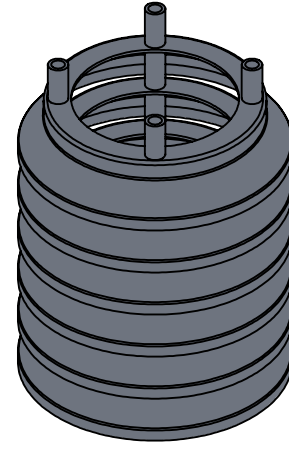
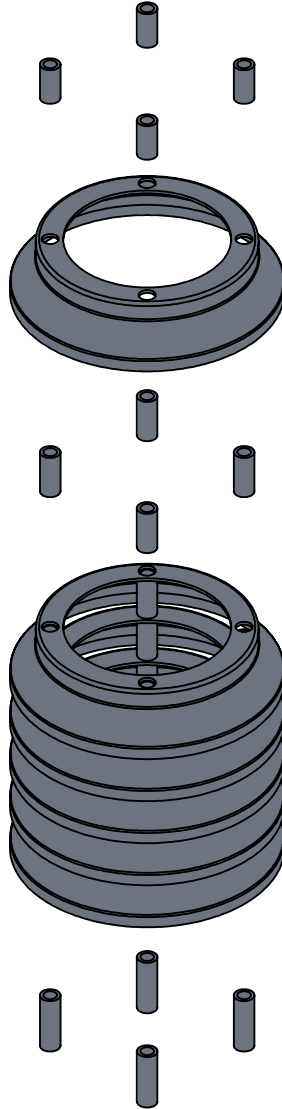
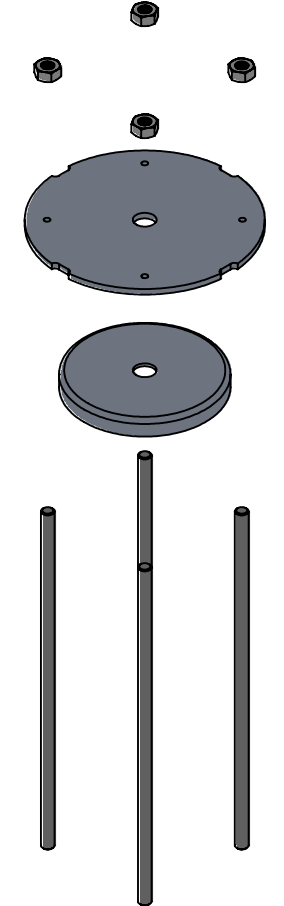
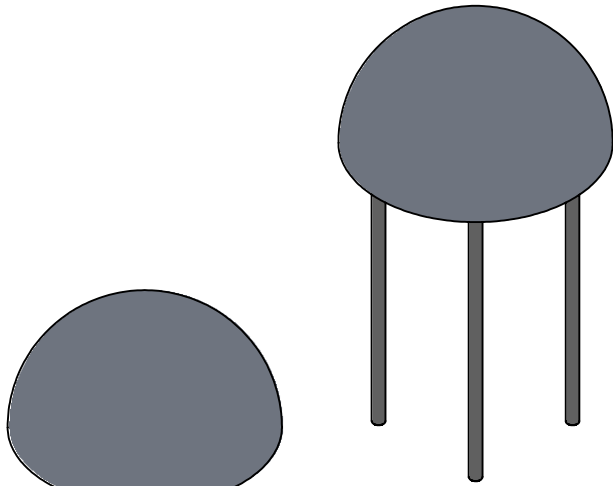

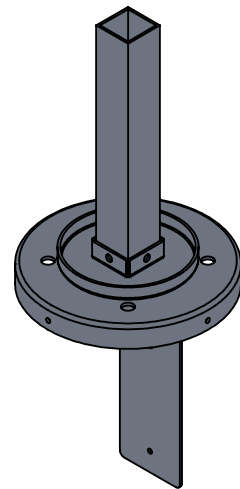
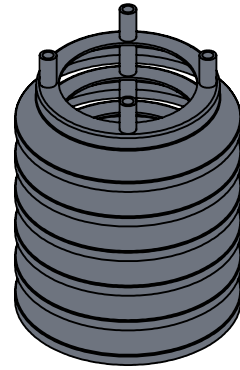
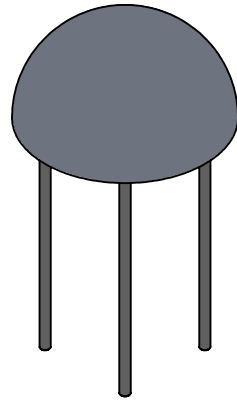

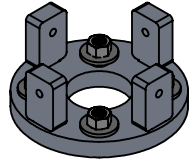
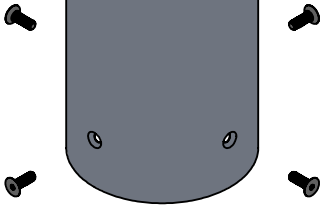
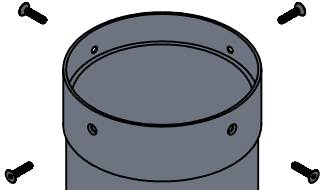
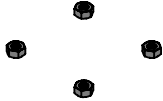
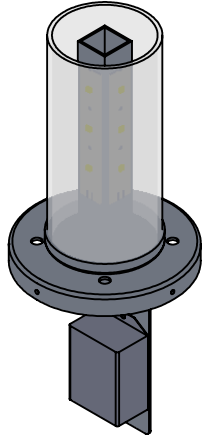
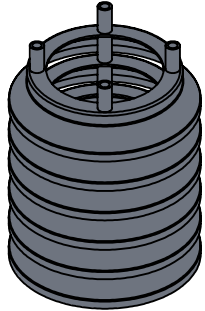
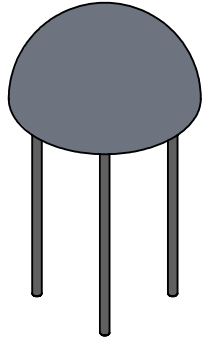

- ALL MEASUREMENTS FROM TOP RIM OF CYLINDER

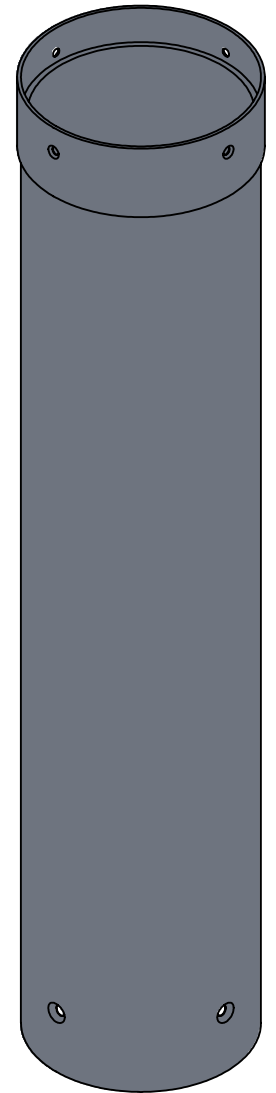
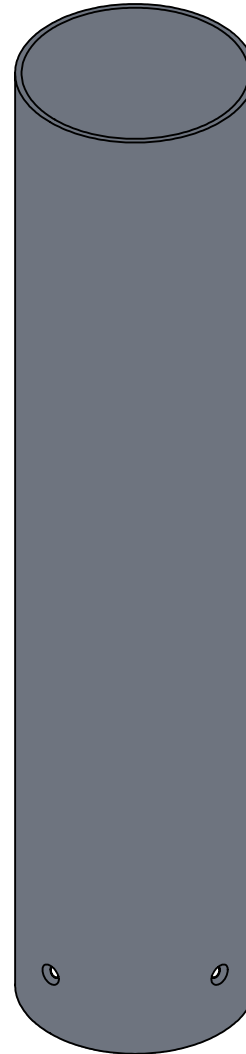
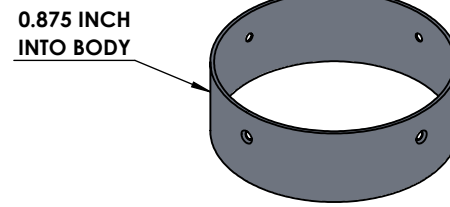
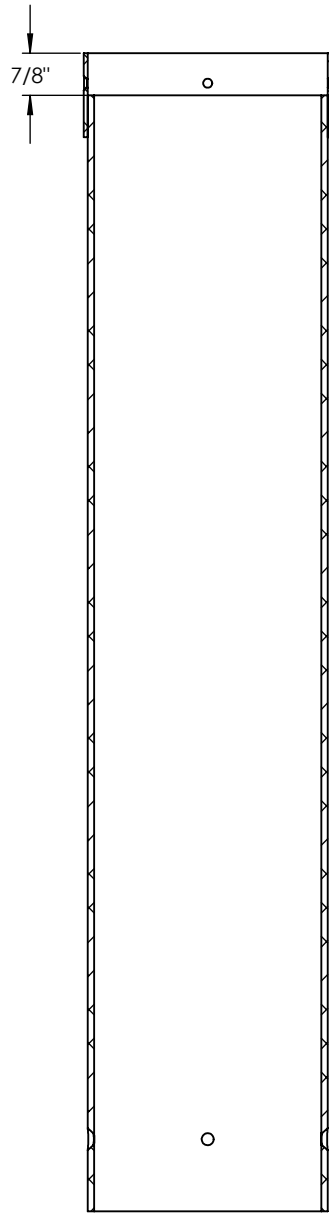
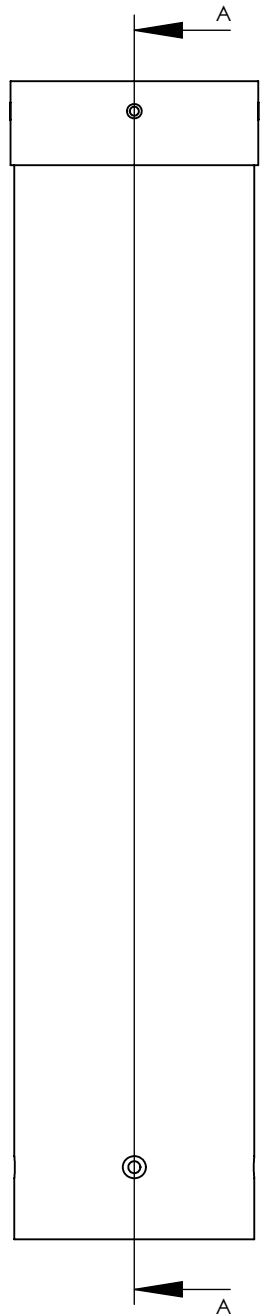

SECTION A-A

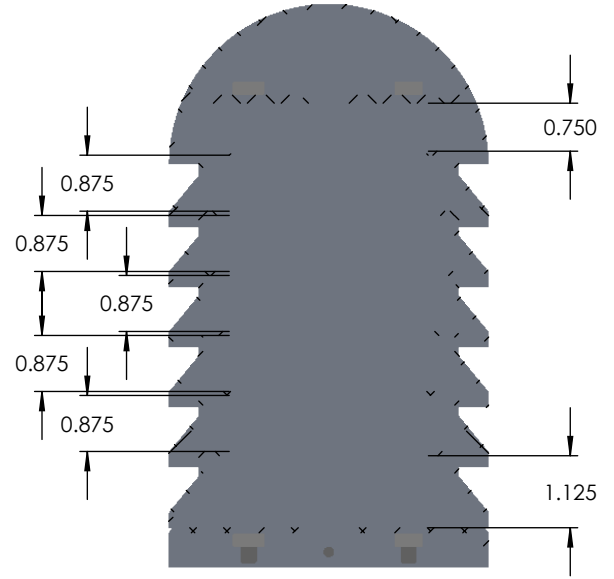
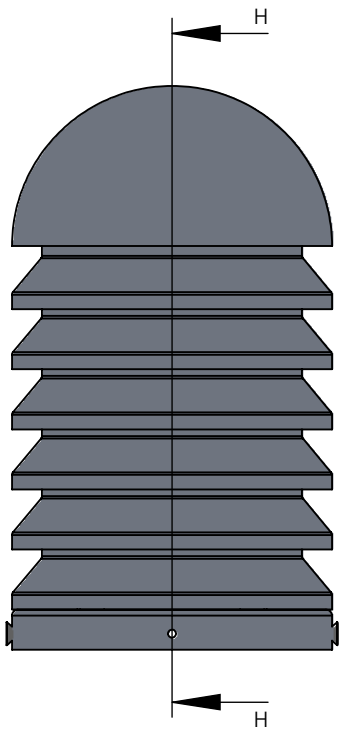

SECTION H-H
SCALE 1 : 3

0.75 INCHES
X
4

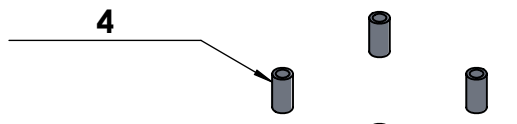

0.875 INCH
X
20

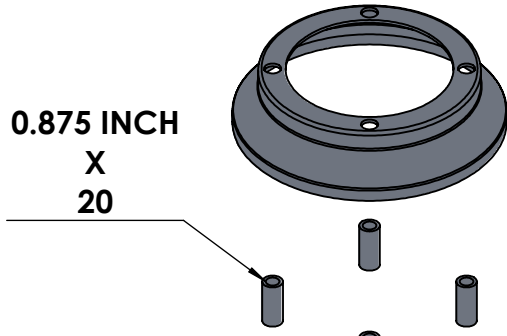

1-1/8 INCHES
X
4

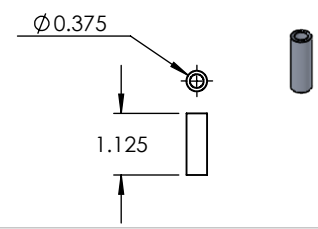
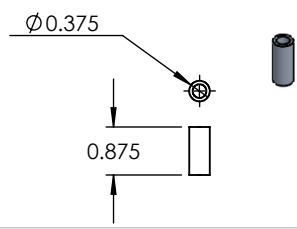
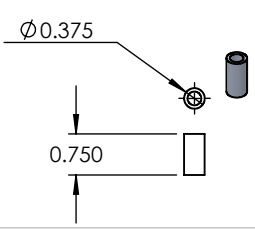
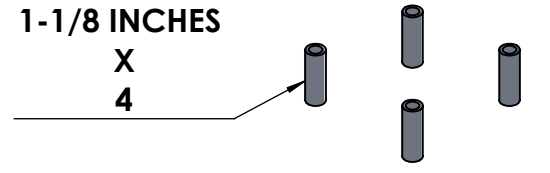

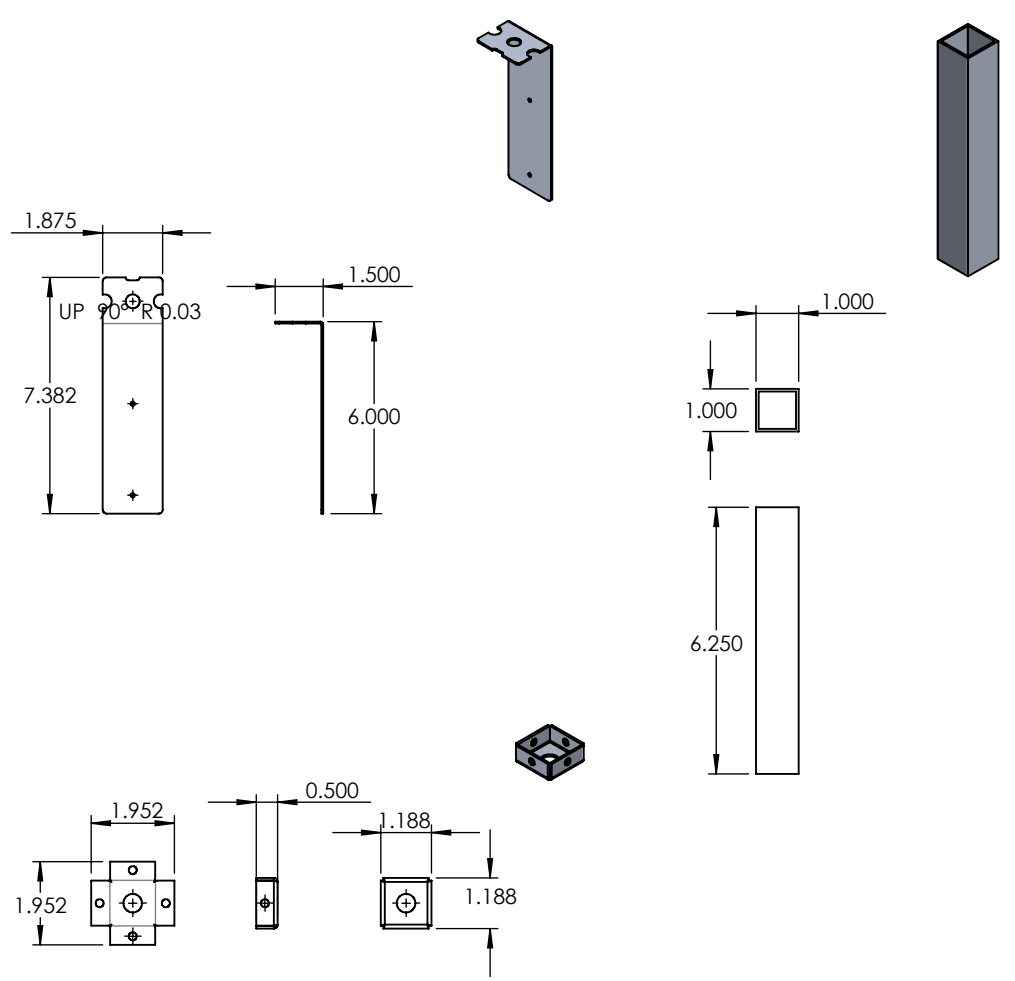
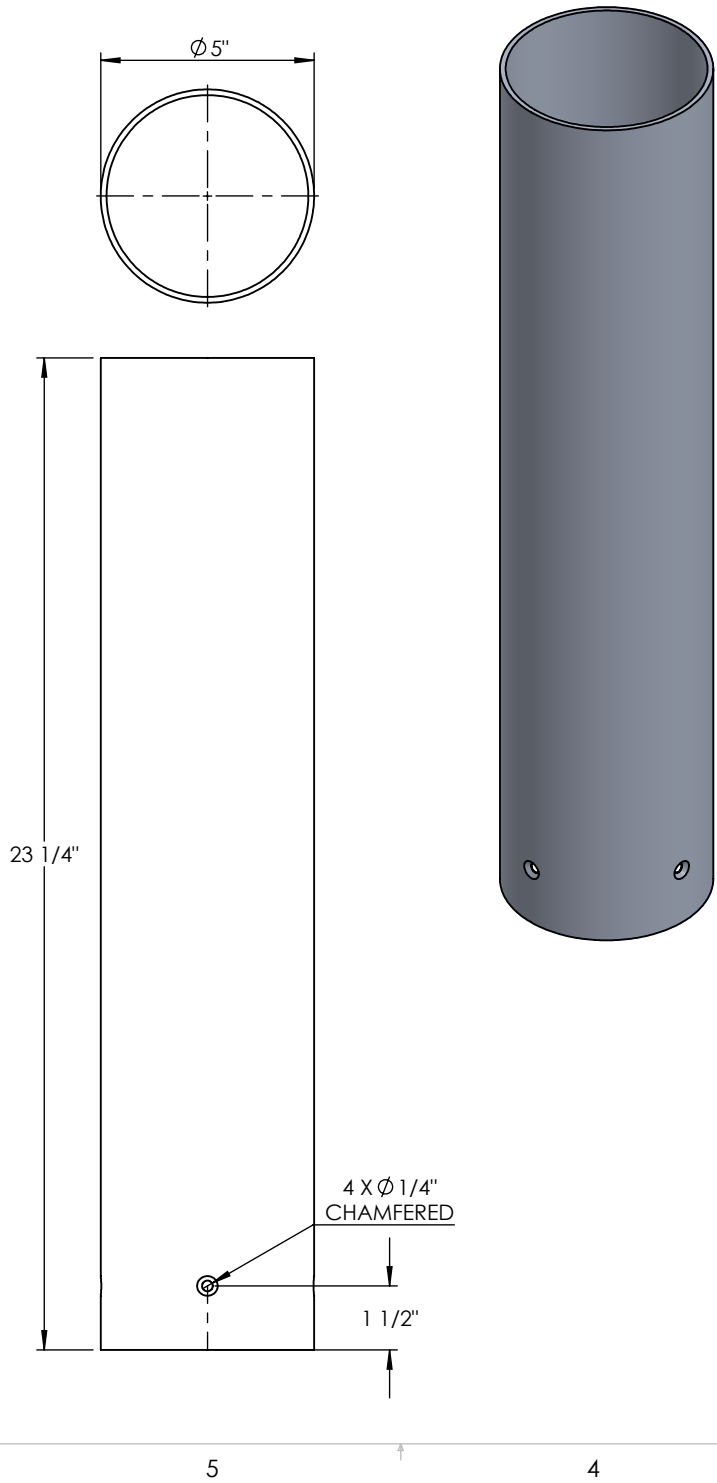

UNLESS OTHERWISE SPECIFIED:		NAME	DATE	5" CYLINDER TUBE	
DIMENSIONS ARE IN INCHES		DRAWN			
TOLERANCES:		CHECKED		EC-STR-B-32-12W-9-CF	
FRACTIONAL ±		ENG APPR.			
ANGULAR: MACH ± BEND ±		MFG APPR.		A	
TWO PLACE DECIMAL ±		Q.A.			
THREE PLACE DECIMAL ±		COMMENTS:			
INTERPRET GEOMETRIC TOLERANCING PER:					
MATERIAL					
FINISH					
DO NOT SCALE DRAWING					

5

4

3

2

1

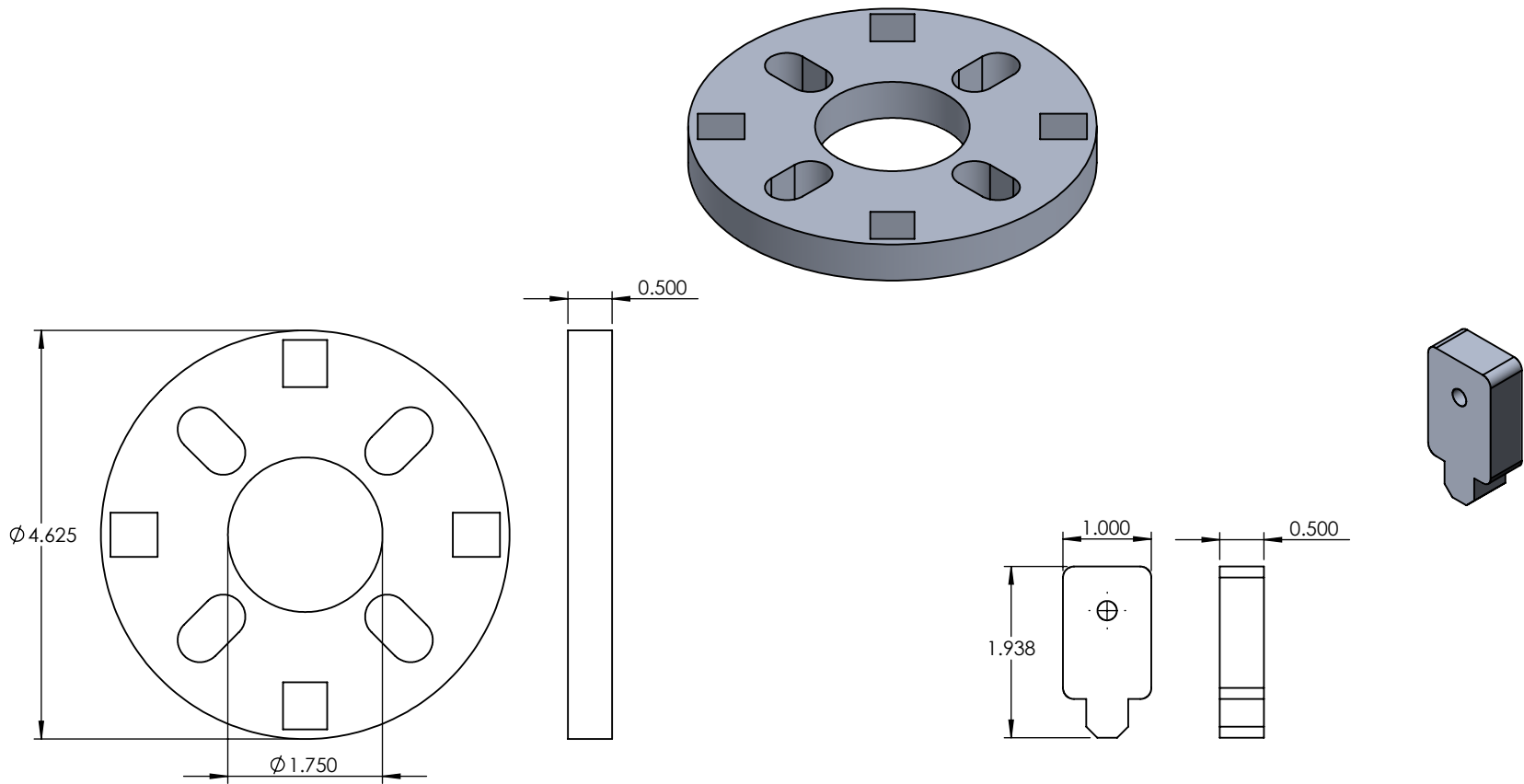

		UNLESS OTHERWISE SPECIFIED:	NAME	DATE	ALUMINUM 0.500" PLATE	
		DIMENSIONS ARE IN INCHES	DRAWN		TITLE:	
		TOLERANCES:	CHECKED		EC-STR-B-32-12W-9-CF	
		FRACTIONAL ±	ENG APPR.		SIZE	DWG. NO.
		ANGULAR: MACH ± BEND ±	MFG APPR.		A	REV
		TWO PLACE DECIMAL ±	Q.A.		SCALE: 1:2	WEIGHT:
		THREE PLACE DECIMAL ±	COMMENTS:		SHEET 9 OF 18	
		INTERPRET GEOMETRIC TOLERANCING PER:				
		MATERIAL				
NEXT ASSY	USED ON	FINISH				
APPLICATION		DO NOT SCALE DRAWING				

5

4

3

2

1

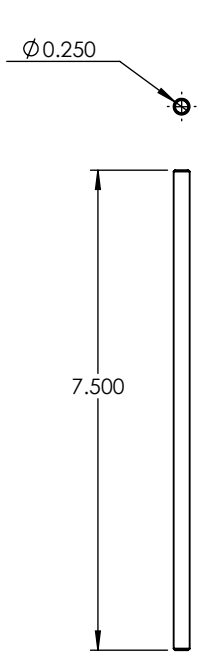
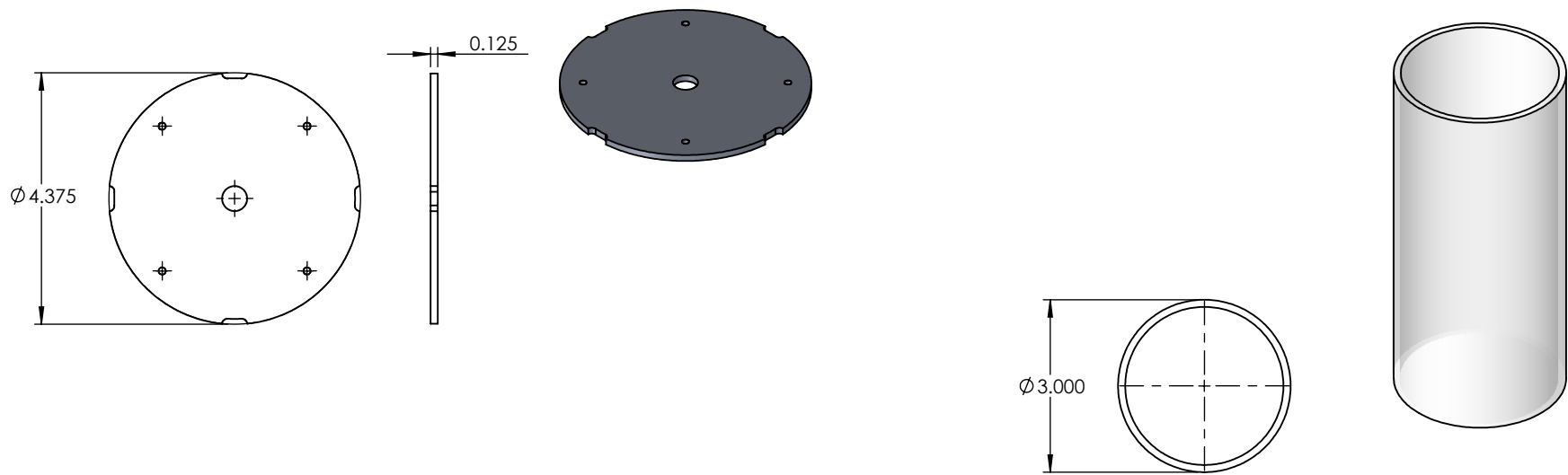

THREADED ROD

PROPRIETARY AND CONFIDENTIAL
 THE INFORMATION CONTAINED IN THIS DRAWING IS THE SOLE PROPERTY OF <INSERT COMPANY NAME HERE>. ANY REPRODUCTION IN PART OR AS A WHOLE WITHOUT THE WRITTEN PERMISSION OF <INSERT COMPANY NAME HERE> IS PROHIBITED.

		UNLESS OTHERWISE SPECIFIED:	NAME	DATE	ACRYLIC	
		DIMENSIONS ARE IN INCHES TOLERANCES: FRACTIONAL ± ANGULAR: MACH ± BEND ± TWO PLACE DECIMAL ± THREE PLACE DECIMAL ±	DRAWN			
		INTERPRET GEOMETRIC TOLERANCING PER:	CHECKED		EC-STR-B-32-12W-9-CF	
		MATERIAL	ENG APPR.			
		FINISH	MFG APPR.		SIZE	DWG. NO.
NEXT ASSY	USED ON		Q.A.		A	
APPLICATION		DO NOT SCALE DRAWING	COMMENTS:		SCALE: 1:3	WEIGHT:
5	4	3	2	1	SHEET 10 OF 18	

ITEM NO.	PART NUMBER	DESCRIPTION	QTY.
1	EC-STR-B-32-12W-9-CF-SPUN TOP CAP	SPUN ALUMINUM 0.080"	1

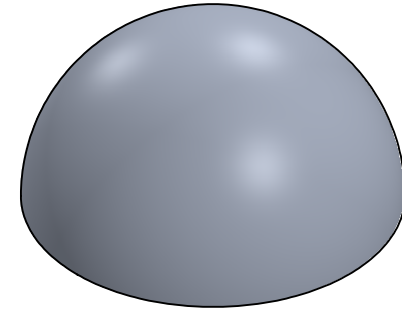
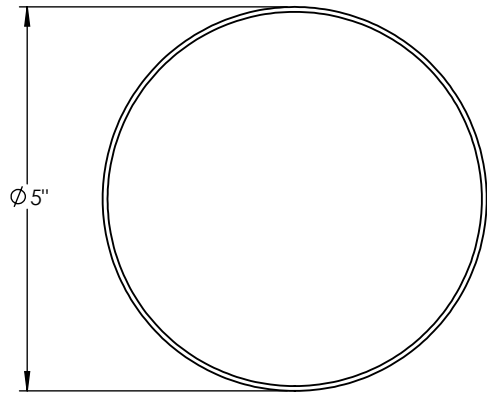
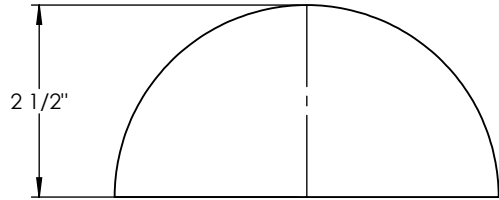

PROPRIETARY AND CONFIDENTIAL
 THE INFORMATION CONTAINED IN THIS DRAWING IS THE SOLE PROPERTY OF <INSERT COMPANY NAME HERE>. ANY REPRODUCTION IN PART OR AS A WHOLE WITHOUT THE WRITTEN PERMISSION OF <INSERT COMPANY NAME HERE> IS PROHIBITED.

		UNLESS OTHERWISE SPECIFIED:	NAME	DATE
		DIMENSIONS ARE IN INCHES TOLERANCES: FRACTIONAL ± ANGULAR: MACH ± BEND ± TWO PLACE DECIMAL ± THREE PLACE DECIMAL ±	DRAWN	
		INTERPRET GEOMETRIC TOLERANCING PER:	CHECKED	
		MATERIAL	ENG APPR.	
		FINISH	MFG APPR.	
NEXT ASSY	USED ON		Q.A.	
APPLICATION		DO NOT SCALE DRAWING	COMMENTS:	

TITLE: SPUN ALUMINUM 0.080"		
EC-STR-B-32-12W-9-CF		
SIZE A	DWG. NO.	REV
SCALE: 1:2.5WEIGHT:		SHEET 11 OF 18

ITEM NO.	PART NUMBER	DESCRIPTION	QTY.
1	EC-STR-B-32-12W-9-CF-SPUN CONE SEAT	SPUN ALUMINUM 0.080"	1

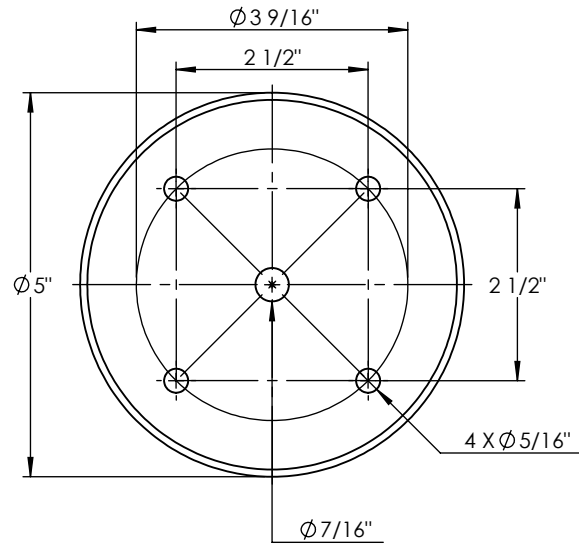
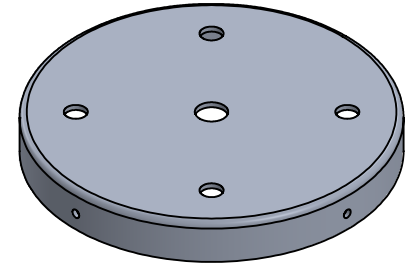
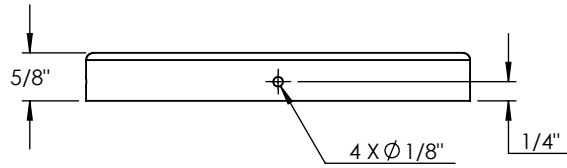

<p>PROPRIETARY AND CONFIDENTIAL</p> <p>THE INFORMATION CONTAINED IN THIS DRAWING IS THE SOLE PROPERTY OF <INSERT COMPANY NAME HERE>. ANY REPRODUCTION IN PART OR AS A WHOLE WITHOUT THE WRITTEN PERMISSION OF <INSERT COMPANY NAME HERE> IS PROHIBITED.</p>			UNLESS OTHERWISE SPECIFIED:		NAME	DATE	SPUN ALUMINUM 0.080"	
			DIMENSIONS ARE IN INCHES				TITLE:	
			TOLERANCES:				EC-STR-B-32-12W-9-CF	
			FRACTIONAL ±		DRAWN		SIZE DWG. NO. REV	
			ANGULAR: MACH ± BEND ±		CHECKED		SCALE: 1:2.5 WEIGHT: SHEET 12 OF 18	
		TWO PLACE DECIMAL ±		ENG APPR.				
		THREE PLACE DECIMAL ±		MFG APPR.				
		INTERPRET GEOMETRIC TOLERANCING PER:		Q.A.				
		MATERIAL		COMMENTS:				
	NEXT ASSY	USED ON	FINISH					
	APPLICATION		DO NOT SCALE DRAWING					

5

4

3

2

1

ITEM NO.	PART NUMBER	DESCRIPTION	QTY.
1	VEN-10-42-8-E26-1-TBK-120V-SPUN CONE SEAT	SPUN ALUMINUM 0.080"	1

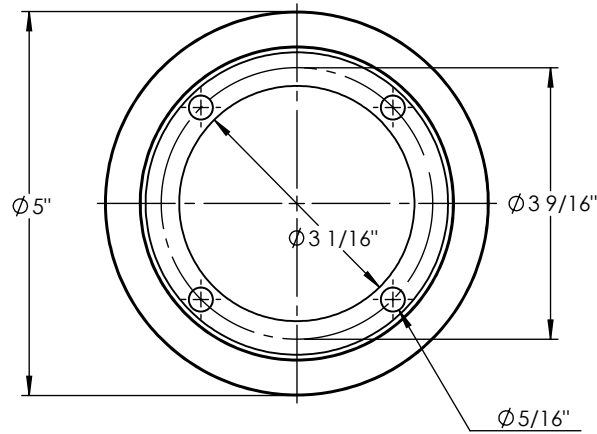
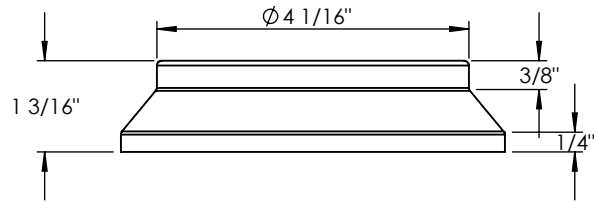
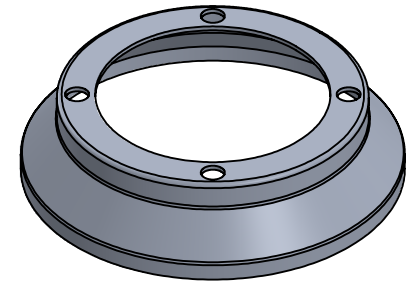

PROPRIETARY AND CONFIDENTIAL
 THE INFORMATION CONTAINED IN THIS DRAWING IS THE SOLE PROPERTY OF <INSERT COMPANY NAME HERE>. ANY REPRODUCTION IN PART OR AS A WHOLE WITHOUT THE WRITTEN PERMISSION OF <INSERT COMPANY NAME HERE> IS PROHIBITED.

		UNLESS OTHERWISE SPECIFIED:		NAME	DATE
		DIMENSIONS ARE IN INCHES	DRAWN		
		TOLERANCES:	CHECKED		
		FRACTIONAL ±	ENG APPR.		
		ANGULAR: MACH ± BEND ±	MFG APPR.		
		TWO PLACE DECIMAL ±	Q.A.		
		THREE PLACE DECIMAL ±	COMMENTS:		
		INTERPRET GEOMETRIC TOLERANCING PER:			
		MATERIAL			
NEXT ASSY	USED ON	FINISH			
APPLICATION		DO NOT SCALE DRAWING			

SPUN ALUMINUM 0.0635"		
TITLE:		
EC-STR-B-32-12W-9-CF		
SIZE	DWG. NO.	REV
A		
SCALE: 1:2.5WEIGHT:		SHEET 13 OF 18

ITEM NO.	PART NUMBER	DESCRIPTION	QTY.
1	EC-STR-B-32-12W-9-CF-SPUN LENS CAP	SPUN ALUMINUM 0.080"	1

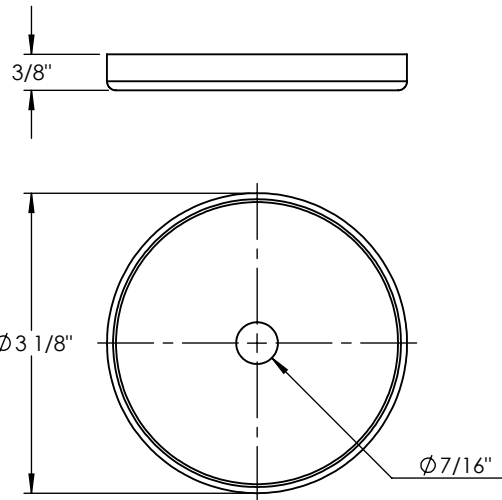
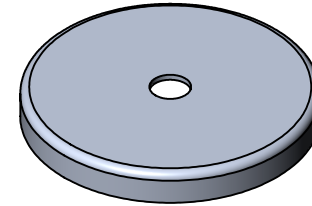

<p>PROPRIETARY AND CONFIDENTIAL THE INFORMATION CONTAINED IN THIS DRAWING IS THE SOLE PROPERTY OF <INSERT COMPANY NAME HERE>. ANY REPRODUCTION IN PART OR AS A WHOLE WITHOUT THE WRITTEN PERMISSION OF <INSERT COMPANY NAME HERE> IS PROHIBITED.</p>			UNLESS OTHERWISE SPECIFIED:		NAME	DATE	SPUN ALUMINUM 0.080"			
			DIMENSIONS ARE IN INCHES	DRAWN			TITLE: EC-STR-B-32-12W-9-CF			
			TOLERANCES:	CHECKED						
			FRACTIONAL ±	ENG APPR.						
			ANGULAR: MACH ± BEND ±	MFG APPR.						
		TWO PLACE DECIMAL ±	Q.A.				SIZE	DWG. NO.	REV	
		THREE PLACE DECIMAL ±	INTERPRET GEOMETRIC TOLERANCING PER:	COMMENTS:			A			
		MATERIAL	FINISH							
	NEXT ASSY	USED ON	APPLICATION	DO NOT SCALE DRAWING			SCALE: 1:2	WEIGHT:	SHEET 14 OF 18	

ITEM NO.	PART NUMBER	DESCRIPTION	QTY.
1	EC-STR-B-32-12W-9-CF-TUBE SLEEVE	SPUN ALUMINUM 0.080"	1

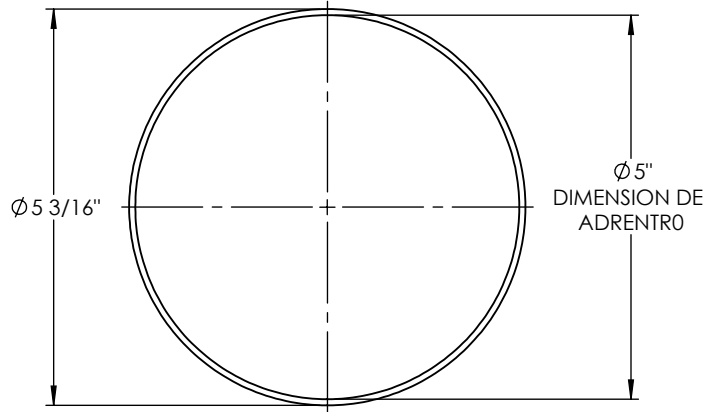
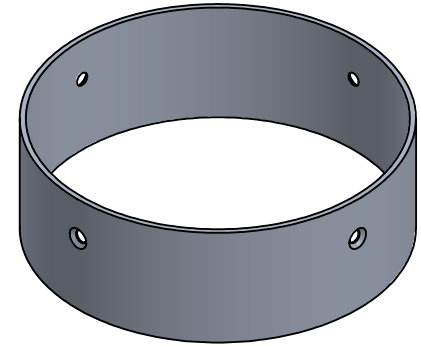
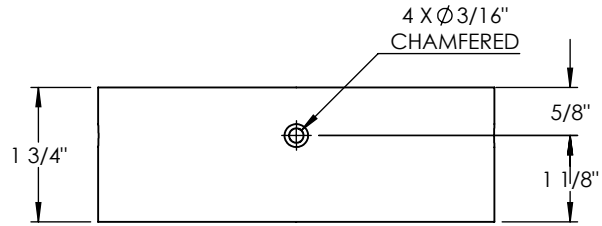

UNLESS OTHERWISE SPECIFIED: DIMENSIONS ARE IN INCHES TOLERANCES: FRACTIONAL ± ANGULAR: MACH ± BEND ± TWO PLACE DECIMAL ± THREE PLACE DECIMAL ±		NAME	DATE	SPUN ALUMINUM 0.080"	
	DRAWN				
	CHECKED			SIZE	DWG. NO.
	ENG APPR.				
	MFG APPR.			SCALE: 1:2.5	WEIGHT:
INTERPRET GEOMETRIC TOLERANCING PER: MATERIAL FINISH	COMMENTS:				

PROPRIETARY AND CONFIDENTIAL
 THE INFORMATION CONTAINED IN THIS DRAWING IS THE SOLE PROPERTY OF <INSERT COMPANY NAME HERE>. ANY REPRODUCTION IN PART OR AS A WHOLE WITHOUT THE WRITTEN PERMISSION OF <INSERT COMPANY NAME HERE> IS PROHIBITED.

NEXT ASSY	USED ON
APPLICATION	

DO NOT SCALE DRAWING

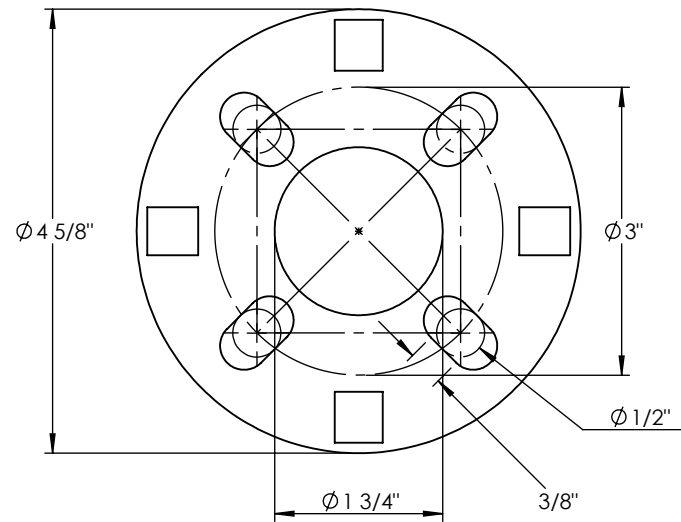
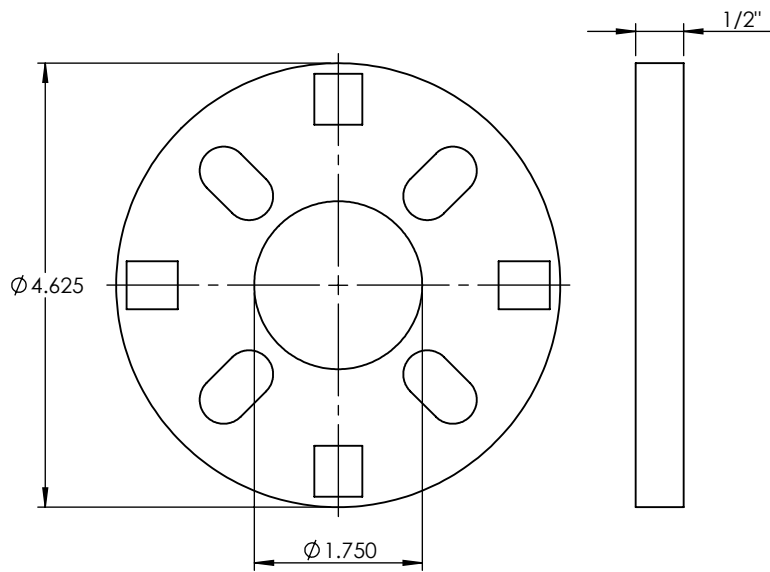
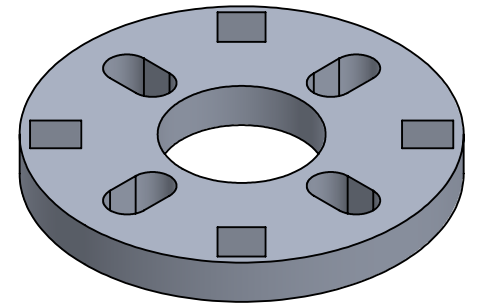

		UNLESS OTHERWISE SPECIFIED:	NAME	DATE	ALUMINUM 0.500" PLATE	
		DIMENSIONS ARE IN INCHES	DRAWN		TITLE:	
		TOLERANCES:	CHECKED		EC-STR-B-32-12W-9-CF	
		FRACTIONAL ±	ENG APPR.		SIZE	DWG. NO.
		ANGULAR: MACH ± BEND ±	MFG APPR.		A	REV
		TWO PLACE DECIMAL ±	Q.A.		SCALE: 1:2	WEIGHT:
		THREE PLACE DECIMAL ±	COMMENTS:		SHEET 16 OF 18	
		INTERPRET GEOMETRIC TOLERANCING PER:				
		MATERIAL				
NEXT ASSY	USED ON	FINISH				
APPLICATION		DO NOT SCALE DRAWING				

5

4

3

2

1

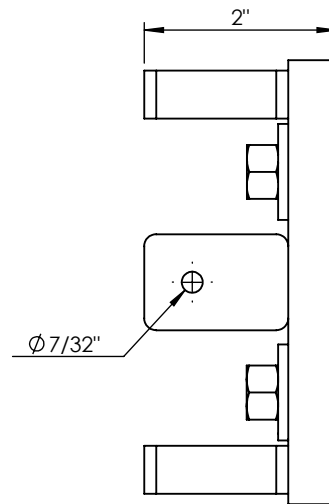
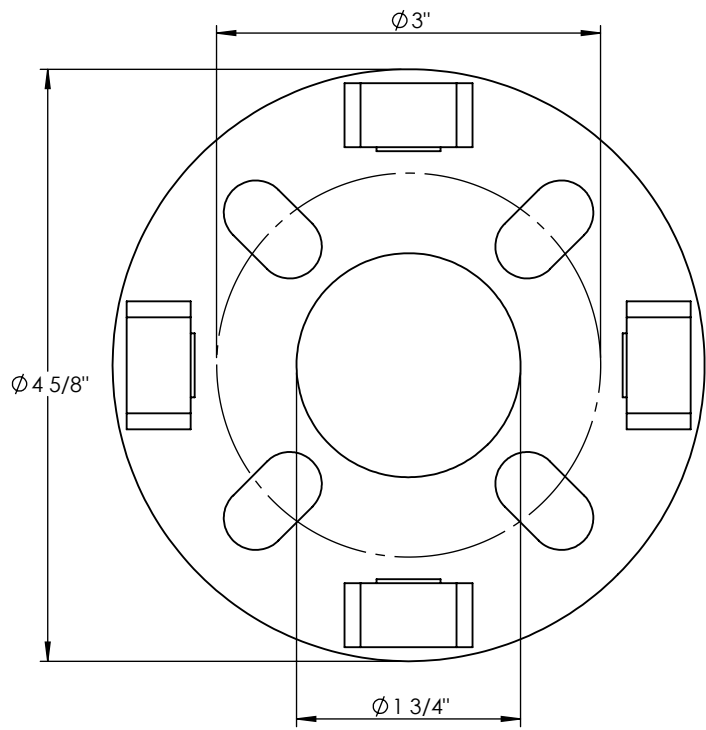
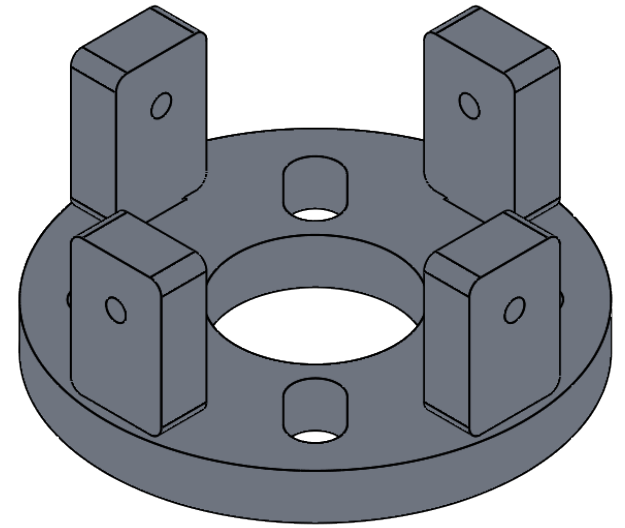

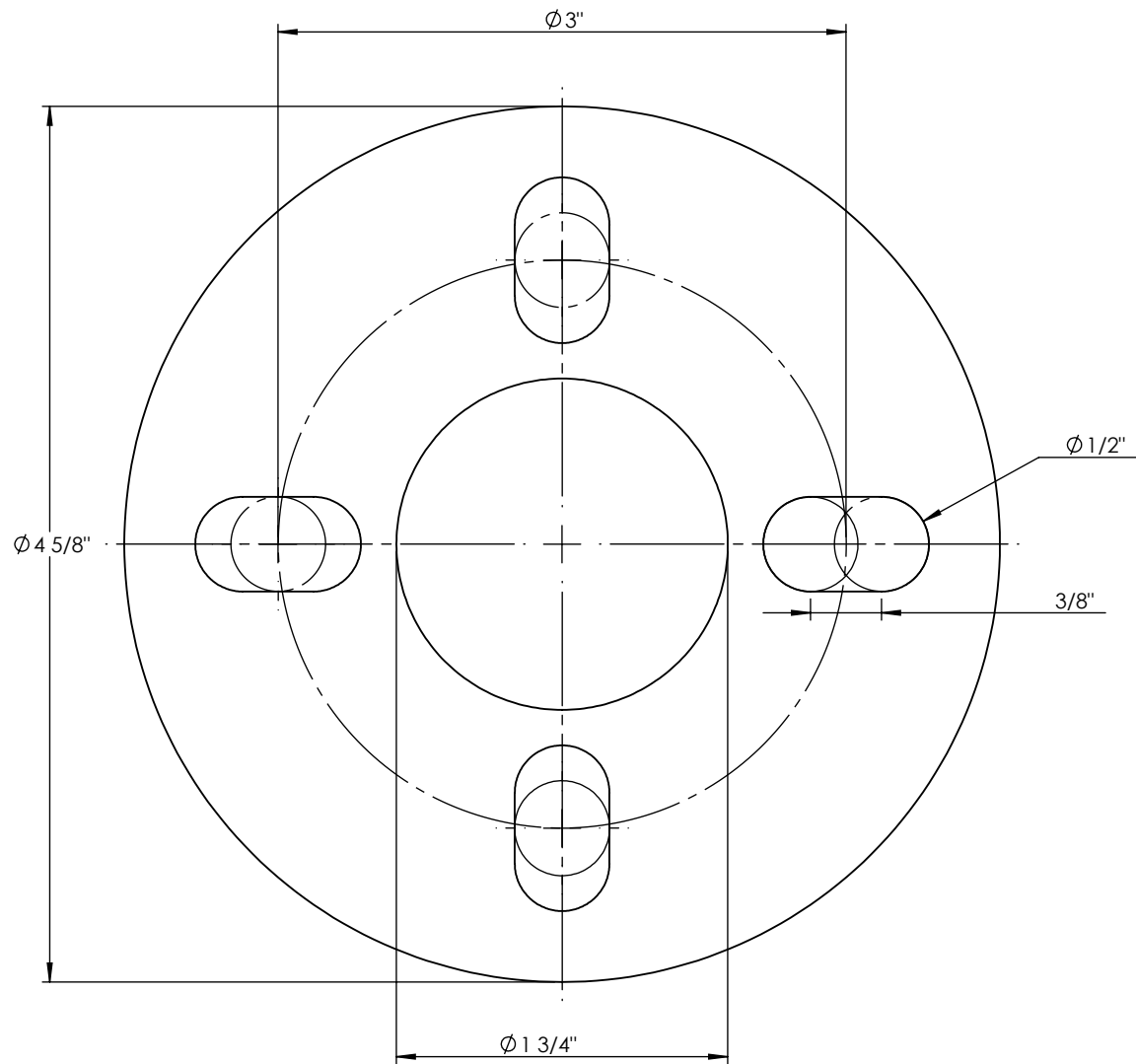

**3/8" X 12" LONG
ANCHOR BOLT SIZE**