

ITEM NO.	PART NUMBER	DESCRIPTION	QTY.	CUT
1	EC-VEN-11-32-5-12W-TUBE BODY	8" ALUMINUM POST	1	
2	EC-VEN-11-32-5-12W-SPUN LENS CAP	SPUN ALUMINUM 0.080"	2	
3	EC-VEN-11-32-5-12W-HEAD BASE PLATE	ALUMINUM 0.125" PLATE	1	
4	EC-VEN-11-32-5-12W-PYRAMID CAP PLATE	ALUMINUM 0.125" PLATE	1	
5	EC-VEN-11-32-5-12W-ANCHOR PLATE	ALUMINUM 0.125" PLATE	1	
6	EC-VEN-11-32-5-12W-PYRAMID CAP	ALUMINUM 0.0635"	1	
7	EC-VEN-11-32-5-12W-HEAD BASE	ALUMINUM 0.0635"	1	
8	EC-VEN-11-32-5-12W-LOUVER	ALUMINUM 0.0635"	5	
9	EC-VEN-11-32-5-12W-TUBE BRACKET	ALUMINUM 0.0635"	1	
10	EC-VEN-11-32-5-12W-DRIVER BRACKET	ALUMINUM 0.0635"	1	
11	EC-VEN-11-32-5-12W-THREADED ROD	3/8" THREADED ROD	4	
12	EC-VEN-11-32-5-12W-0.500" ROUND TUBE	1/2" ALUMINUM TUBE	24	
13	EC-VEN-11-32-5-12W-SQUARE TUBE	1" ALUMINUM TUBE	1	
14	EC-VEN-11-32-5-12W-SPLBP-ACRYLIC	ACRYLIC	1	
15	NIPPLE		1	
16	Espen VEL19070MVH-1	DRIVER	1	
17	AltaILED_PN1012_RevD	LED	4	

UNLESS OTHERWISE SPECIFIED:
 DIMENSIONS ARE IN INCHES
 TOLERANCES:
 FRACTIONAL ± .003
 ANGULAR: MACH ± .01 BEND ±
 TWO PLACE DECIMAL ±
 THREE PLACE DECIMAL ± .001

INTERPRET GEOMETRIC TOLERANCING PER:
 MATERIAL
 FINISH

ALL BEND RADIUS .030"

APPLICATION DO NOT SCALE DRAWING

	NAME	DATE
DRAWN		
CHECKED		
ENG APPR.		
MFG APPR.		
Q.A.		
COMMENTS:		

TITLE:
EC-VEN-11-32-5-12W

SIZE DWG. NO. REV
A

SCALE: 1:8 WEIGHT: SHEET 1 OF 12



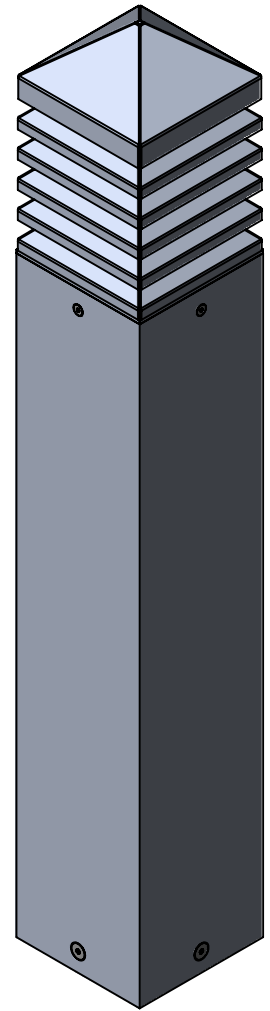
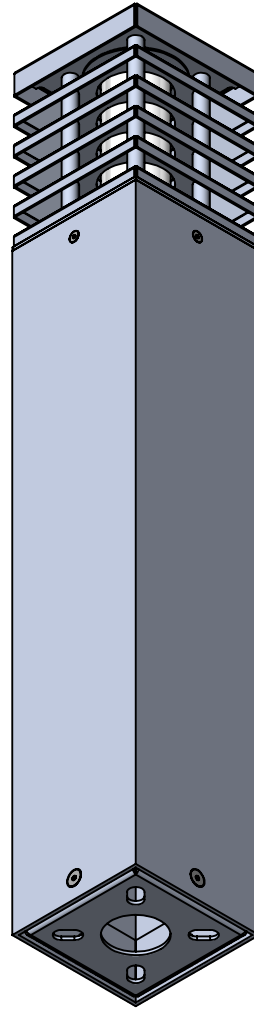
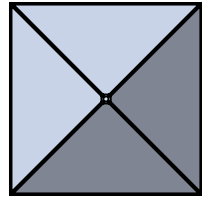
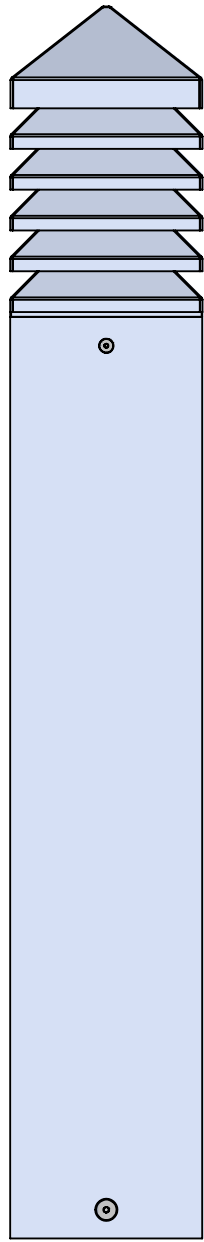

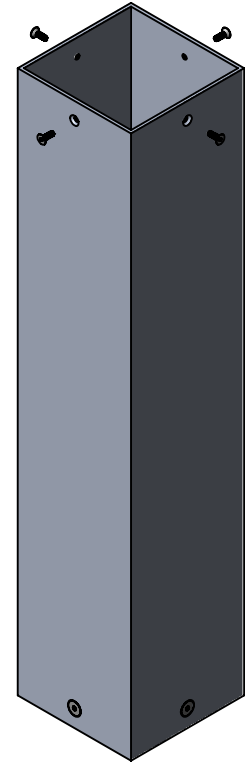
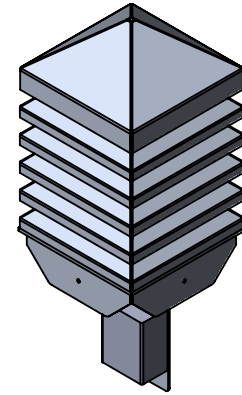
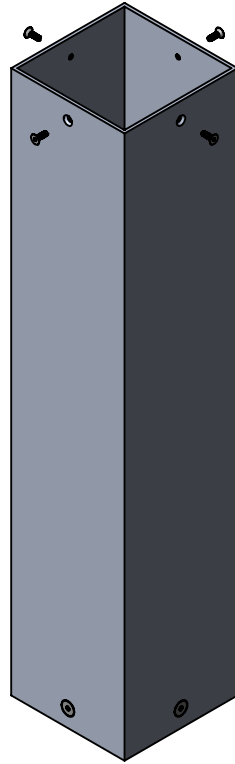
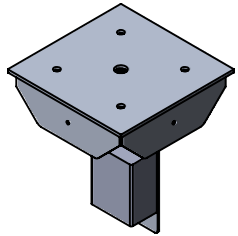
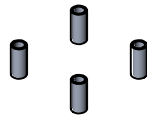
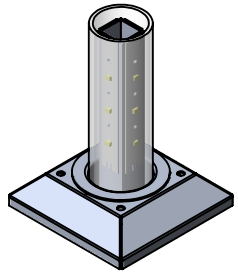
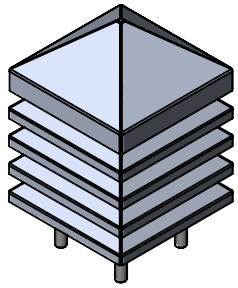

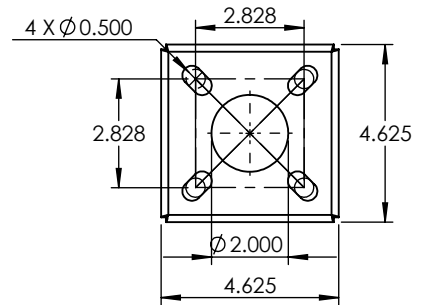
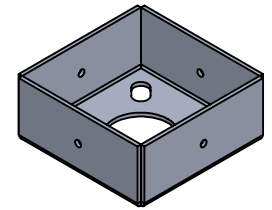
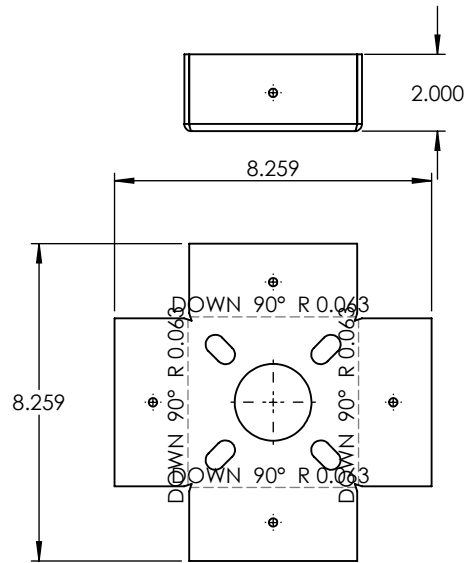
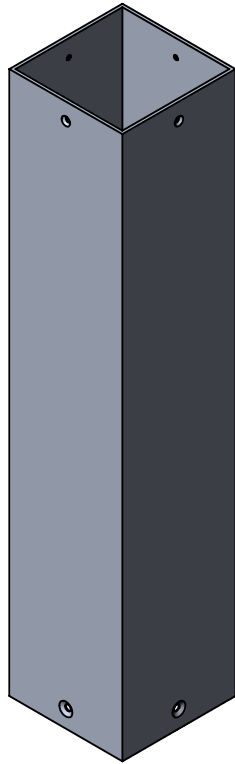
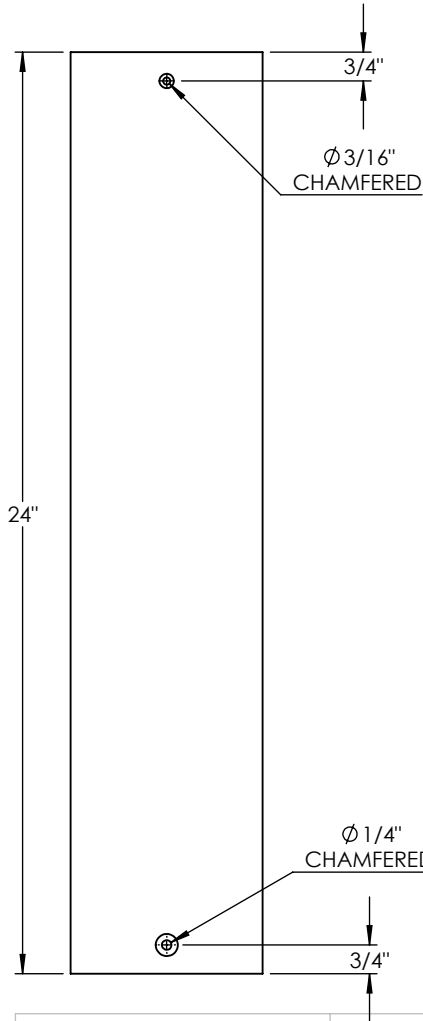
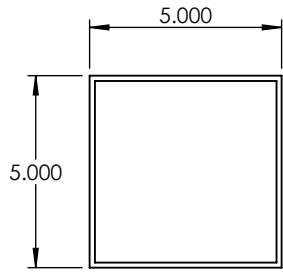

PROPRIETARY AND CONFIDENTIAL
 THE INFORMATION CONTAINED IN THIS DRAWING IS THE SOLE PROPERTY OF <INSERT COMPANY NAME HERE>. ANY REPRODUCTION IN PART OR AS A WHOLE WITHOUT THE WRITTEN PERMISSION OF <INSERT COMPANY NAME HERE> IS PROHIBITED.

NEXT ASSY	USED ON
APPLICATION	

UNLESS OTHERWISE SPECIFIED:	NAME	DATE
DIMENSIONS ARE IN INCHES	DRAWN	
TOLERANCES:	CHECKED	
FRACTIONAL ±	ENG APPR.	
ANGULAR: MACH ± BEND ±	MFG APPR.	
TWO PLACE DECIMAL ±	Q.A.	
THREE PLACE DECIMAL ±	COMMENTS:	
INTERPRET GEOMETRIC TOLERANCING PER:		
MATERIAL		
FINISH		
DO NOT SCALE DRAWING		

8" ALUMINUM POST

TITLE:

EC-VEN-11-32-5-12W

SIZE	DWG. NO.	REV
A		
SCALE: 1:5	WEIGHT:	SHEET 4 OF 12

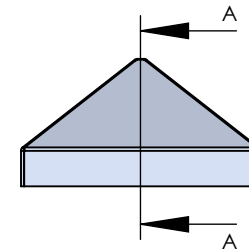
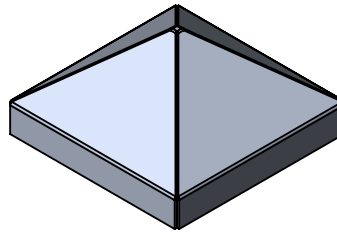
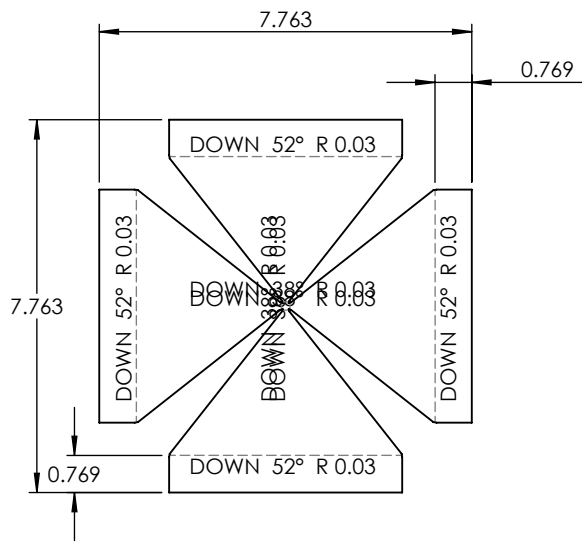

PYRAMID CAP AND
CAP PLATE WELDED

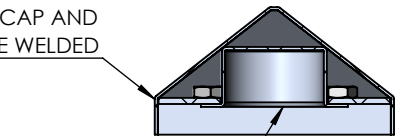

SPUN LENS CAP
WELDED TO PLATE

SECTION A-A

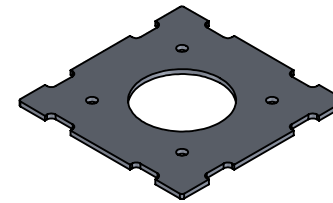
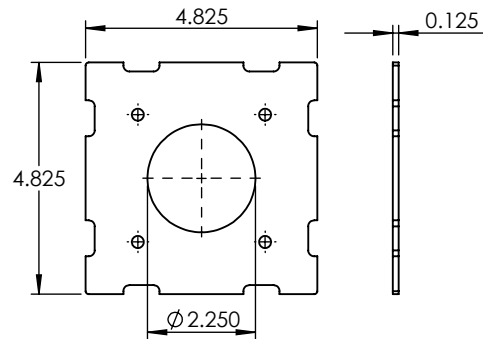
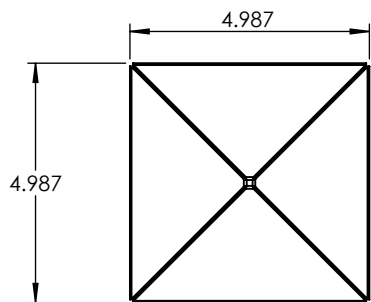
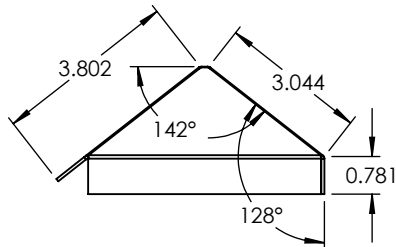

UNLESS OTHERWISE SPECIFIED:

DIMENSIONS ARE IN INCHES
TOLERANCES:
FRACTIONAL ±
ANGULAR: MACH ± BEND ±
TWO PLACE DECIMAL ±
THREE PLACE DECIMAL ±

INTERPRET GEOMETRIC
TOLERANCING PER:

MATERIAL

FINISH

DO NOT SCALE DRAWING

NAME

DATE

DRAWN

CHECKED

ENG APPR.

MFG APPR.

Q.A.

COMMENTS:

ALUMINUM 0.0635"

TITLE:

EC-VEN-11-32-5-12W

SIZE
A

DWG. NO.

REV

SCALE: 1:4

WEIGHT:

SHEET 5 OF 12

PROPRIETARY AND CONFIDENTIAL
THE INFORMATION CONTAINED IN THIS
DRAWING IS THE SOLE PROPERTY OF
<INSERT COMPANY NAME HERE>. ANY
REPRODUCTION IN PART OR AS A WHOLE
WITHOUT THE WRITTEN PERMISSION OF
<INSERT COMPANY NAME HERE> IS
PROHIBITED.

NEXT ASSY

USED ON

APPLICATION

5

4

3

2

1

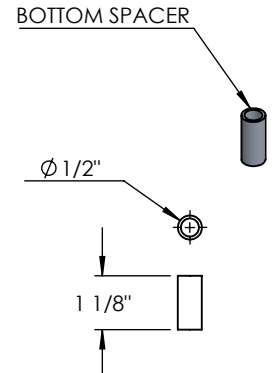
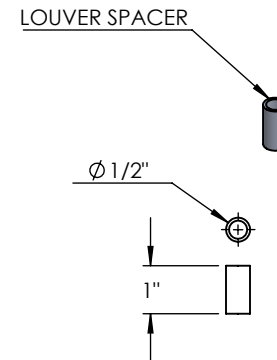
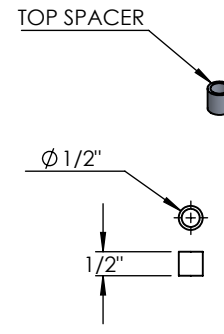
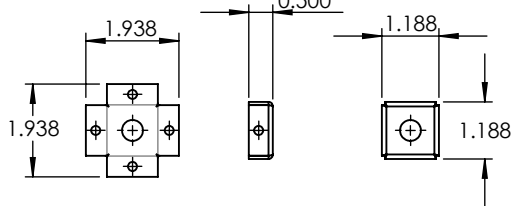
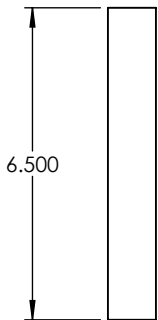
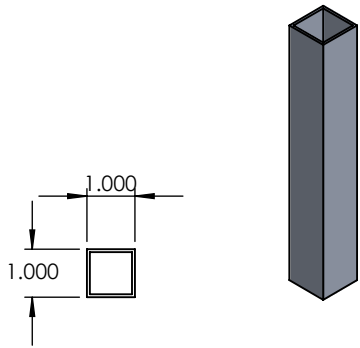
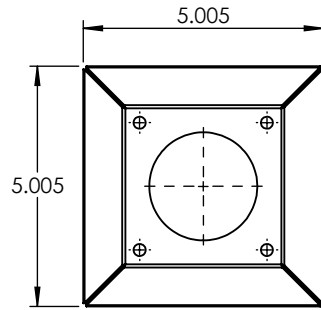
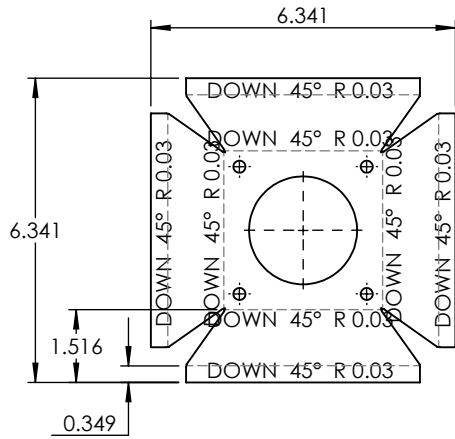
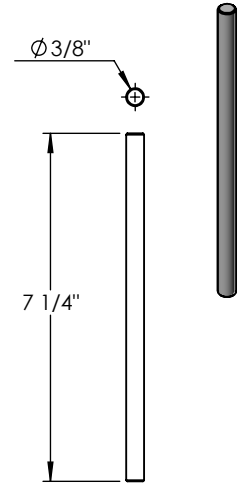
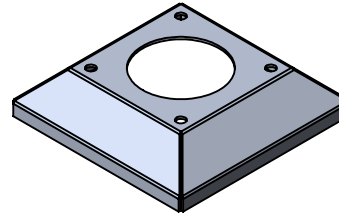
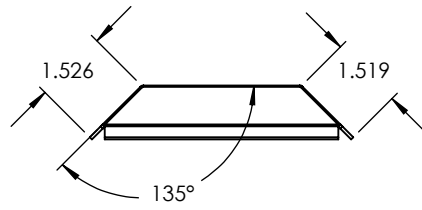
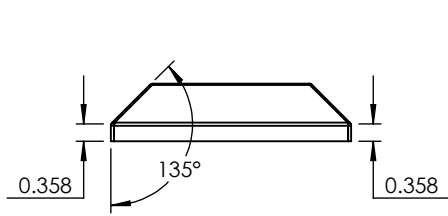

UNLESS OTHERWISE SPECIFIED:

DIMENSIONS ARE IN INCHES
 TOLERANCES:
 FRACTIONAL ±
 ANGULAR: MACH ± BEND ±
 TWO PLACE DECIMAL ±
 THREE PLACE DECIMAL ±

INTERPRET GEOMETRIC TOLERANCING PER:

MATERIAL

FINISH

DO NOT SCALE DRAWING

	NAME	DATE
DRAWN		
CHECKED		
ENG APPR.		
MFG APPR.		
Q.A.		
COMMENTS:		

ALUMINUM 0.0635"

TITLE:

EC-VEN-11-32-5-12W

SIZE	DWG. NO.	REV
A		

SCALE: 1:4 WEIGHT: SHEET 6 OF 12

PROPRIETARY AND CONFIDENTIAL
 THE INFORMATION CONTAINED IN THIS DRAWING IS THE SOLE PROPERTY OF <INSERT COMPANY NAME HERE>. ANY REPRODUCTION IN PART OR AS A WHOLE WITHOUT THE WRITTEN PERMISSION OF <INSERT COMPANY NAME HERE> IS PROHIBITED.

NEXT ASSY	USED ON	APPLICATION

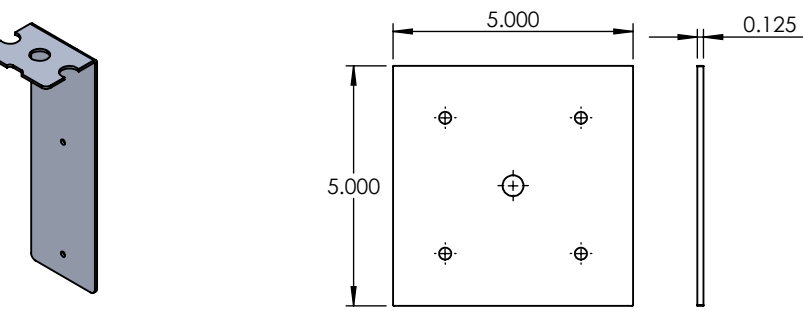
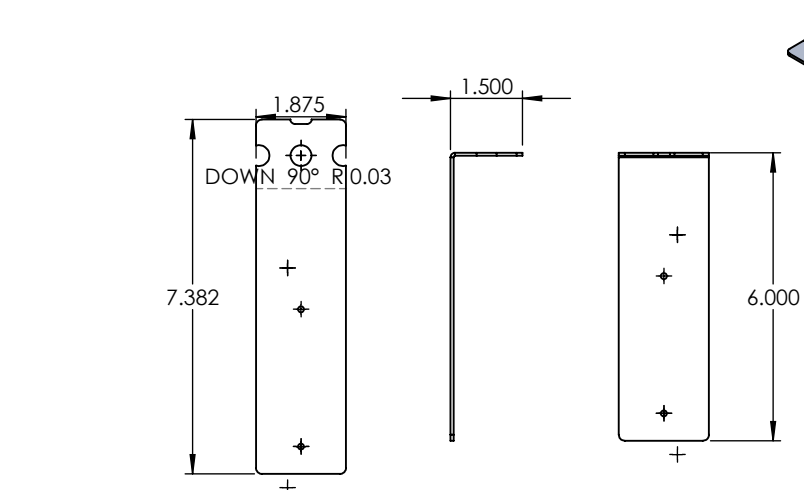
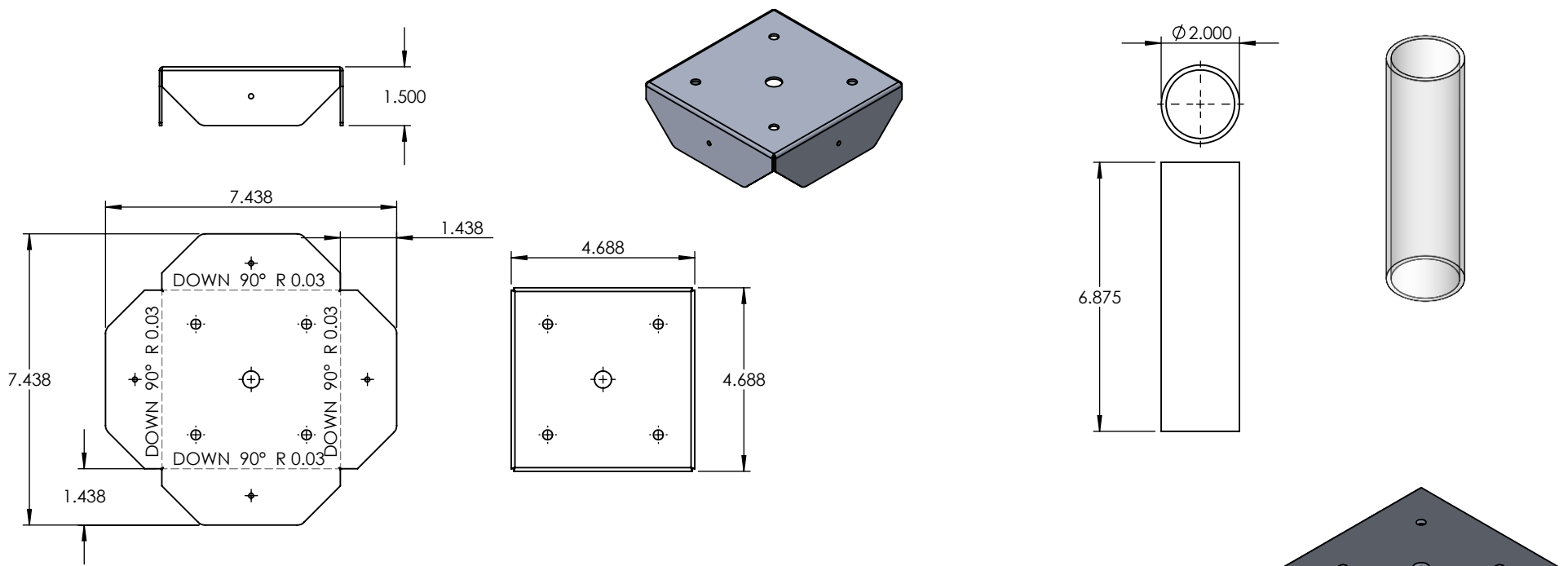

UNLESS OTHERWISE SPECIFIED:

DIMENSIONS ARE IN INCHES
 TOLERANCES:
 FRACTIONAL ±
 ANGULAR: MACH ± BEND ±
 TWO PLACE DECIMAL ±
 THREE PLACE DECIMAL ±

INTERPRET GEOMETRIC TOLERANCING PER:

MATERIAL

FINISH

DO NOT SCALE DRAWING

	NAME	DATE
DRAWN		
CHECKED		
ENG APPR.		
MFG APPR.		
Q.A.		

COMMENTS:

ALUMINUM 0.0635"		
TITLE:		
EC-VEN-11-32-5-12W		
SIZE	DWG. NO.	REV
A		
SCALE: 1:4	WEIGHT:	SHEET 7 OF 12

PROPRIETARY AND CONFIDENTIAL
 THE INFORMATION CONTAINED IN THIS DRAWING IS THE SOLE PROPERTY OF <INSERT COMPANY NAME HERE>. ANY REPRODUCTION IN PART OR AS A WHOLE WITHOUT THE WRITTEN PERMISSION OF <INSERT COMPANY NAME HERE> IS PROHIBITED.

NEXT ASSY	USED ON
APPLICATION	DO NOT SCALE DRAWING

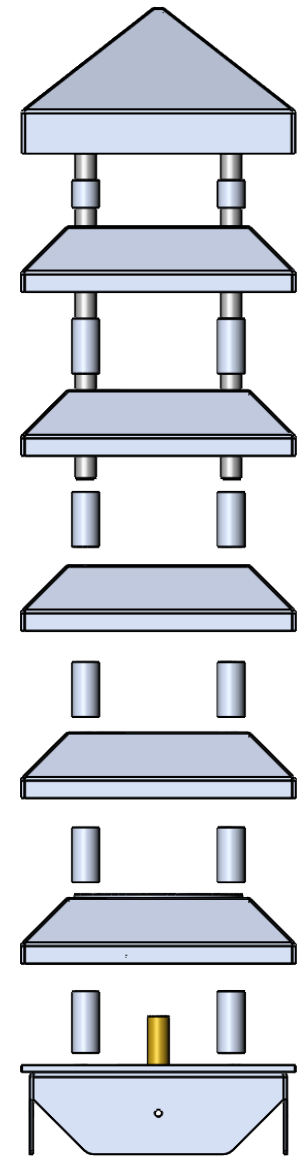
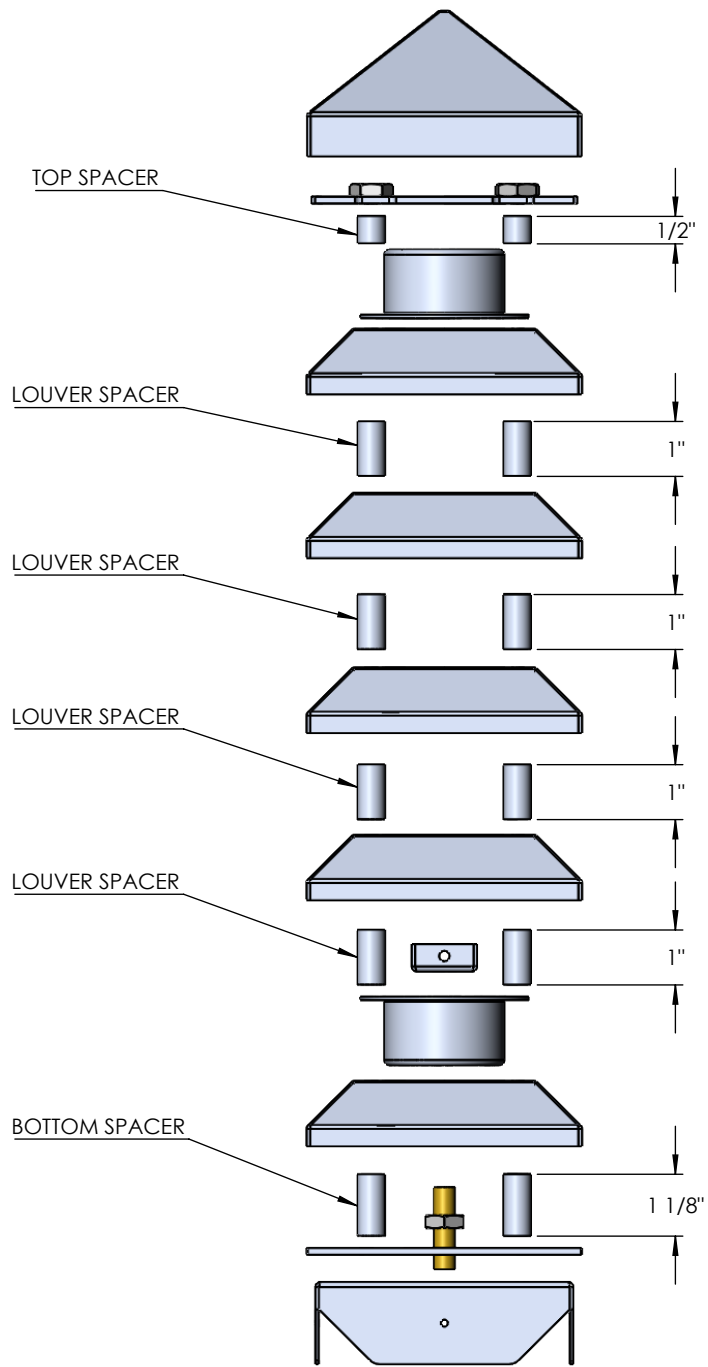

ALL CAP EDGES NEED TO BE WELDED AND CLEANED

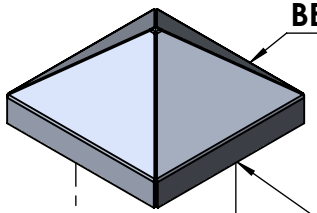

WELDED AS ONE

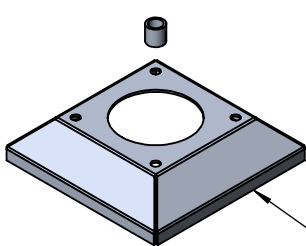
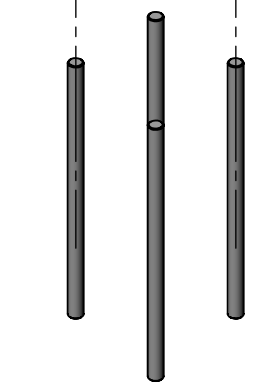
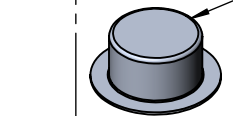
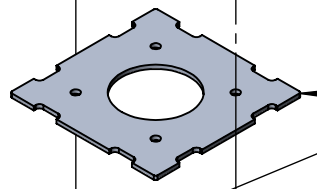

ALL LOUVER EDGES NEED TO BE WELDED AND CLEANED

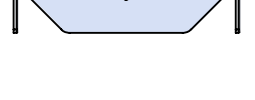
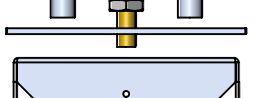
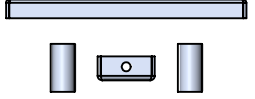
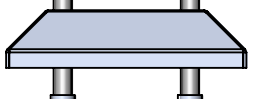
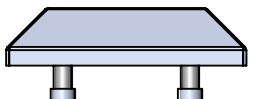
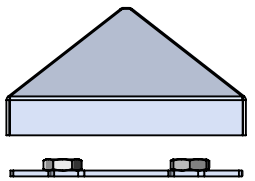
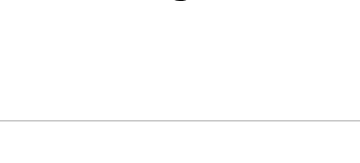
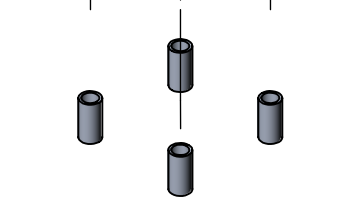
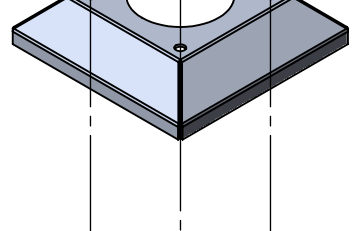
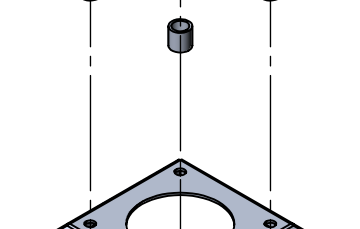
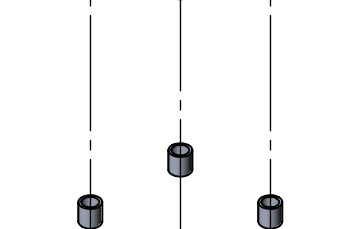
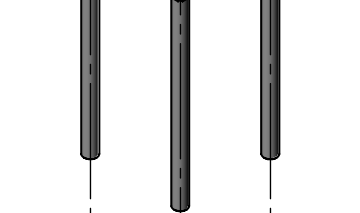
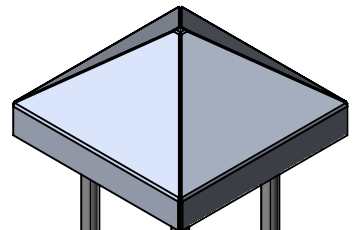

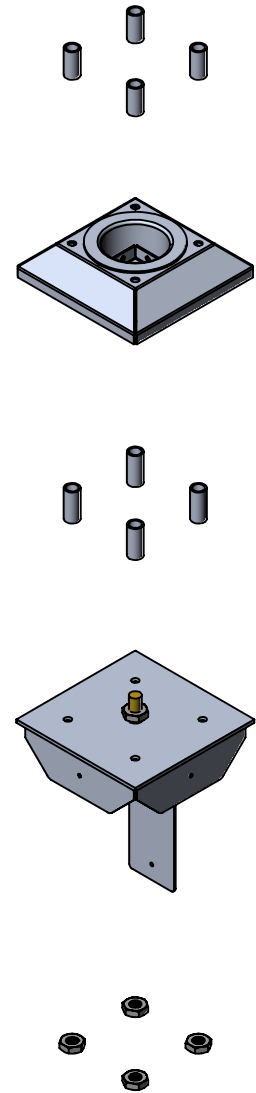
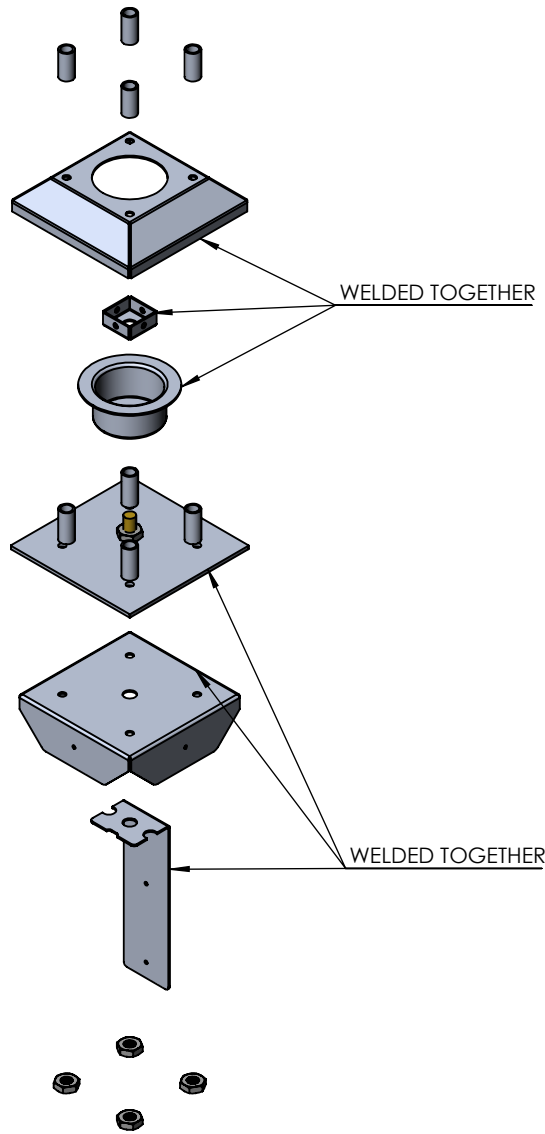
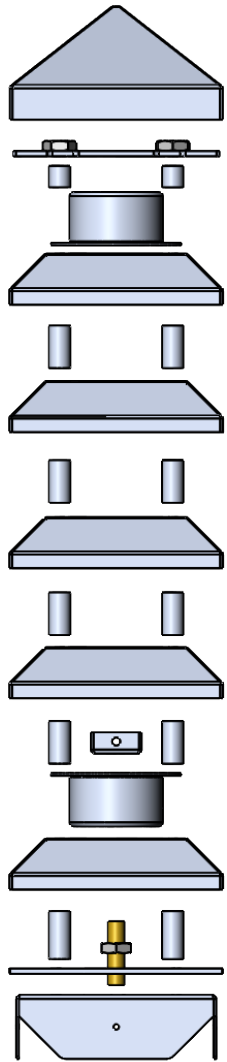

ITEM NO.	PART NUMBER	DESCRIPTION	QTY.
1	EC-VEN-11-32-5-12W-SPUN LENS CAP	SPUN ALUMINUM 0.080"	1

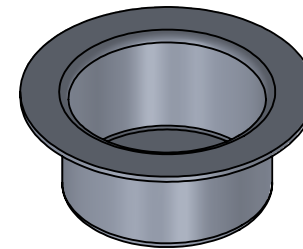
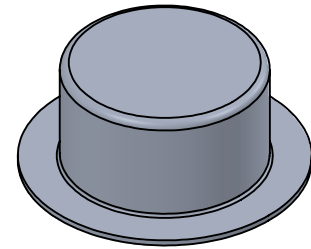
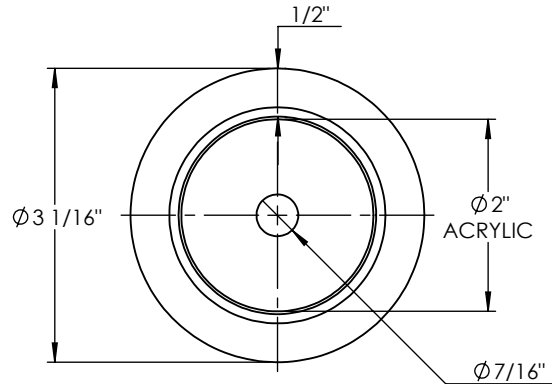
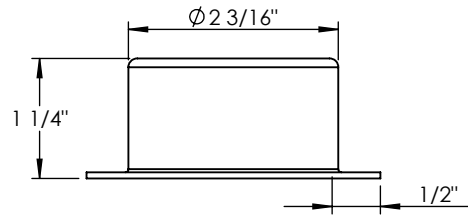

PROPRIETARY AND CONFIDENTIAL
 THE INFORMATION CONTAINED IN THIS DRAWING IS THE SOLE PROPERTY OF <INSERT COMPANY NAME HERE>. ANY REPRODUCTION IN PART OR AS A WHOLE WITHOUT THE WRITTEN PERMISSION OF <INSERT COMPANY NAME HERE> IS PROHIBITED.

		UNLESS OTHERWISE SPECIFIED:	NAME	DATE
		DIMENSIONS ARE IN INCHES TOLERANCES: FRACTIONAL ± ANGULAR: MACH ± BEND ± TWO PLACE DECIMAL ± THREE PLACE DECIMAL ±	DRAWN	
		INTERPRET GEOMETRIC TOLERANCING PER:	CHECKED	
		MATERIAL	ENG APPR.	
		FINISH	MFG APPR.	
NEXT ASSY	USED ON		Q.A.	
APPLICATION		DO NOT SCALE DRAWING	COMMENTS:	

SPUN ALUMINUM 0.080"

TITLE:

EC-VEN-11-32-5-12W

SIZE	DWG. NO.	REV
A		

SCALE: 1:2 WEIGHT: SHEET 11 OF 12

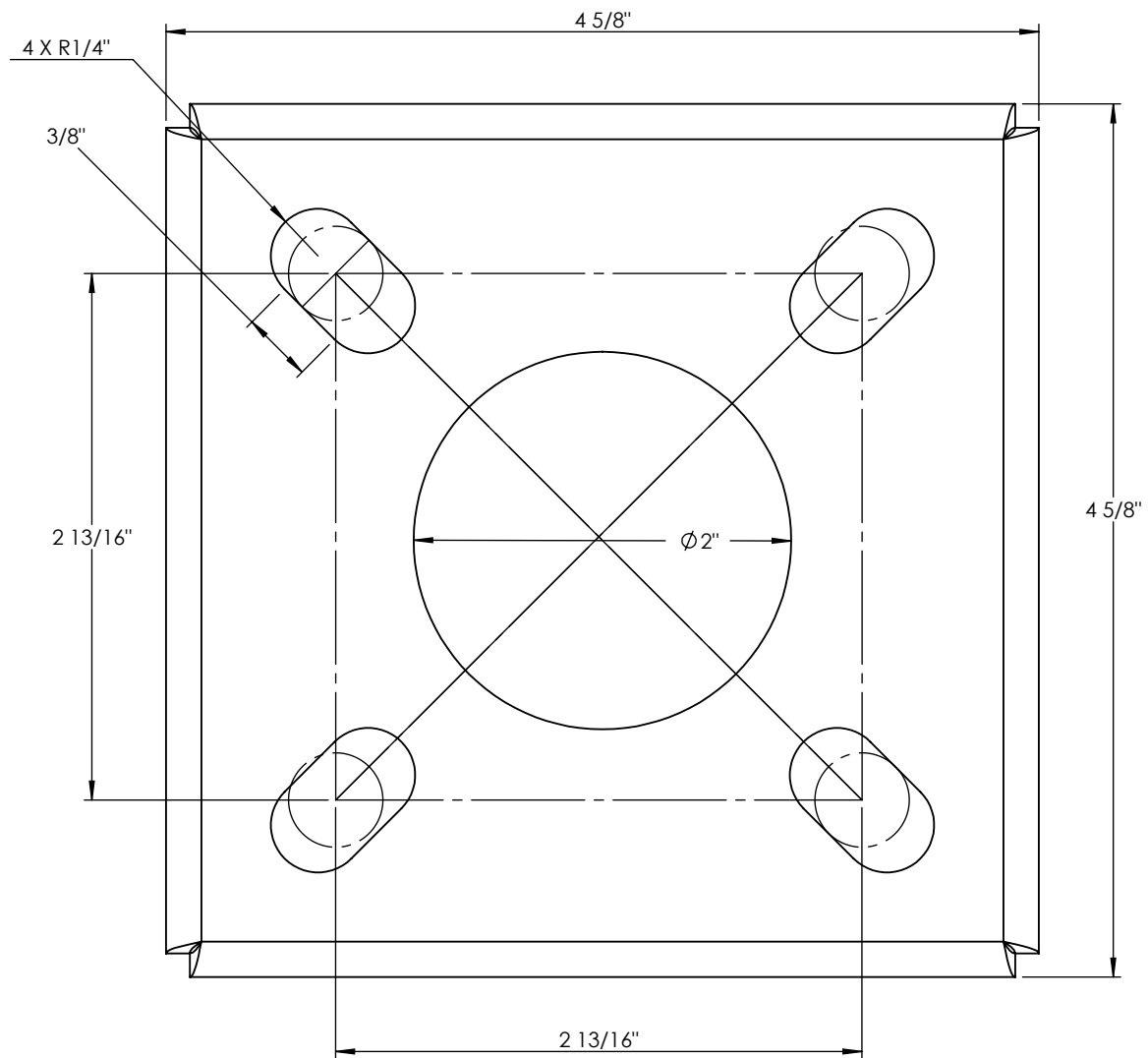

**3/8" X 12" LONG
ANCHOR BOLT SIZE**