

ITEM NO.	PART NUMBER	DESCRIPTION	QTY.	CUT
1	STNLP-16"-24W-AA-A-XXK-SPUN COVER	SPUN ALUMINUM 0.080"	1	
2	STNLP-16"-24W-AA-A-XXK-SPUN BACKPAN	SPUN ALUMINUM 0.080"	1	
3	STNLP-16"-24W-AA-A-XXK-ACRYLIC	ACRYLIC LENS	1	
4	92268A180	Press-Fit Nuts for Sheet Metal	10	
5	92949A194	18-8 SS Hex Drive Screw	6	
6	92949A194	HEX ROUNDED SCREWS (#8-32 THREAD) 3/8" L	4	
7	98164A143	ROUNDED SCREWS (#8-32 THREAD) 1" L	2	
8	90866A009	Zinc-Plated Steel Wing Nut	6	
9	AC29CD700AT2Q LED DRIVER	DRIVER	1	
10	PCN-3000-220X.2-15-700	24-WATT LED PUCK	1	

UNLESS OTHERWISE SPECIFIED:

DIMENSIONS ARE IN INCHES
 TOLERANCES:
 FRACTIONAL ± .003
 ANGULAR: MACH ± .01 BEND ±
 TWO PLACE DECIMAL ±
 THREE PLACE DECIMAL ±.001

INTERPRET GEOMETRIC
 TOLERANCING PER:
 MATERIAL

FINISH

	NAME	DATE
DRAWN		
CHECKED		
ENG APPR.		
MFG APPR.		
Q.A.		

COMMENTS:

TITLE:

STNLP-16"-24W-AA-A-XXK

SIZE	DWG. NO.	REV
A		

SCALE: 1:6.5WEIGHT:

SHEET 1 OF 12



ALL BEND RADIUS .030"

APPLICATION

DO NOT SCALE DRAWING

5

4

3

2

1

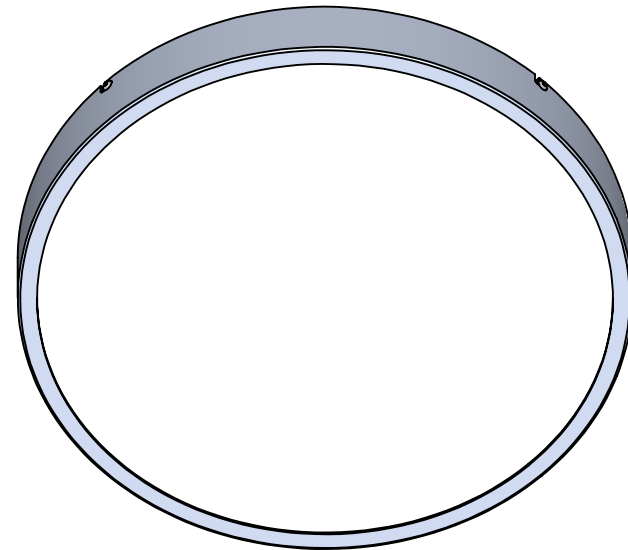
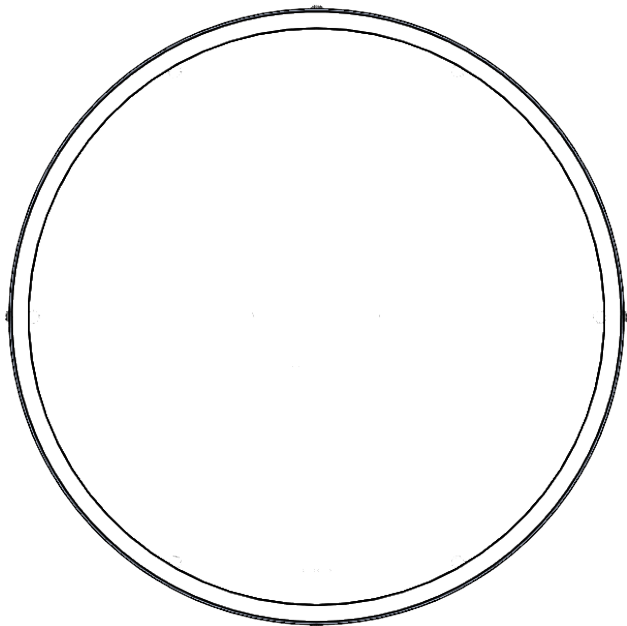
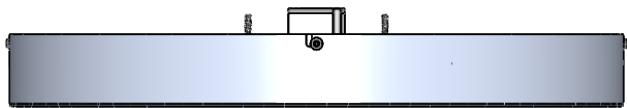
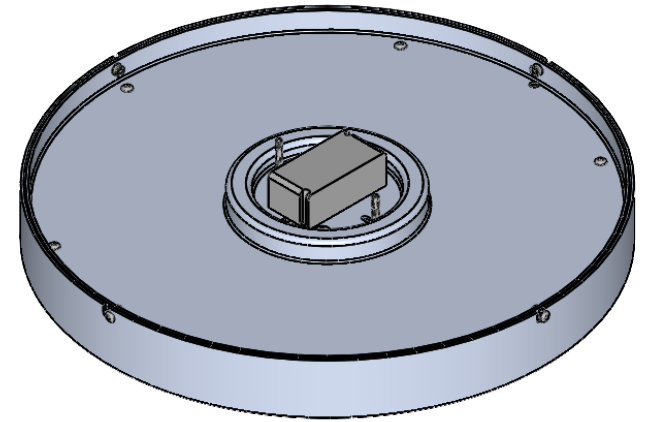
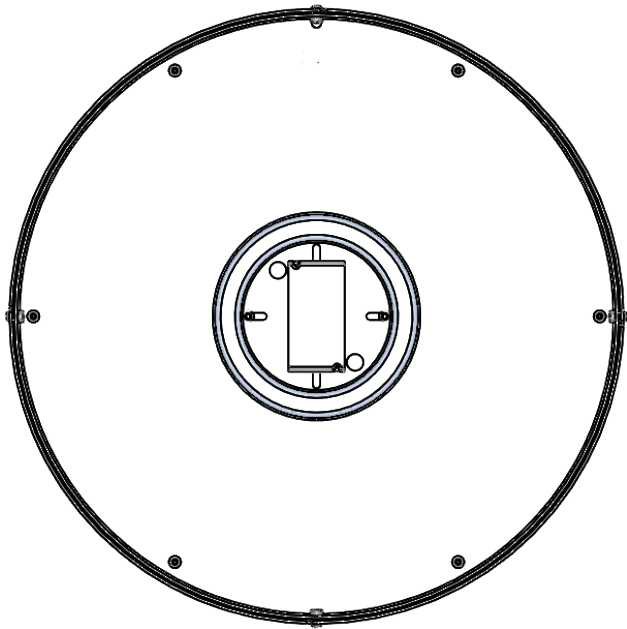

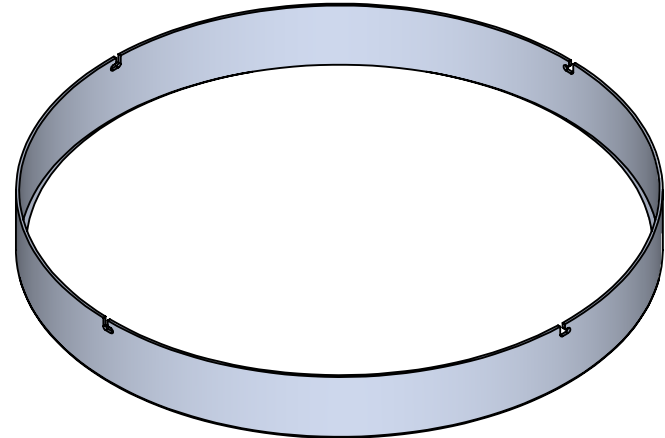
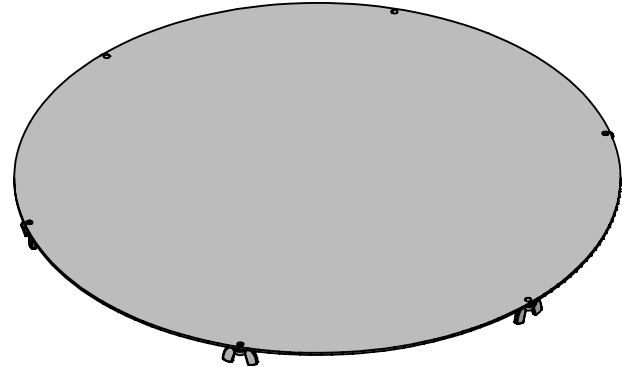
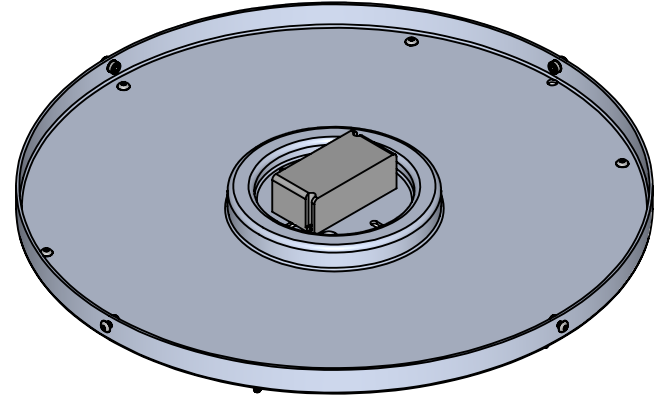
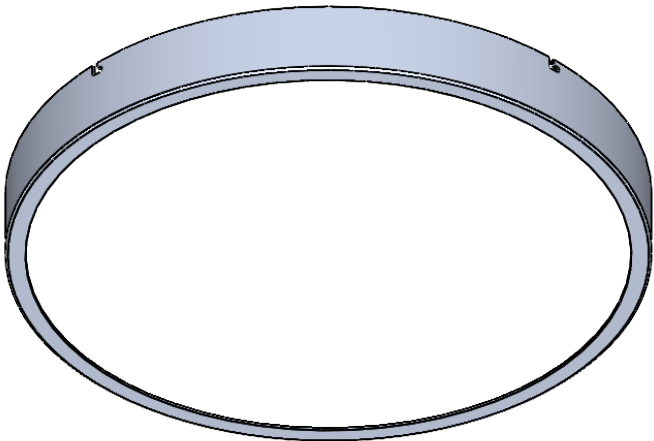
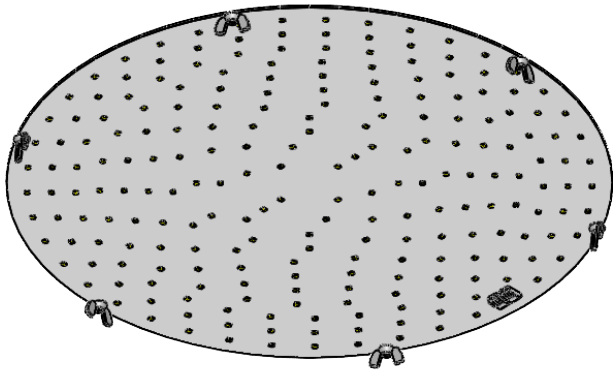
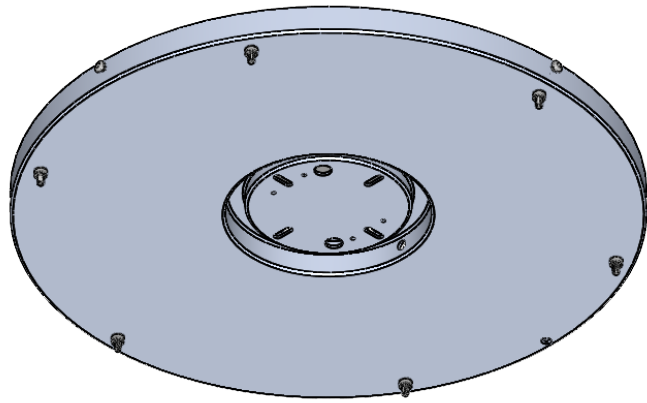

ITEM NO.	PART NUMBER	DESCRIPTION	QTY.
1	STNLP-16"-24W-AA-A-XXK-SPUN BACKPAN	SPUN ALUMINUM 0.080"	1

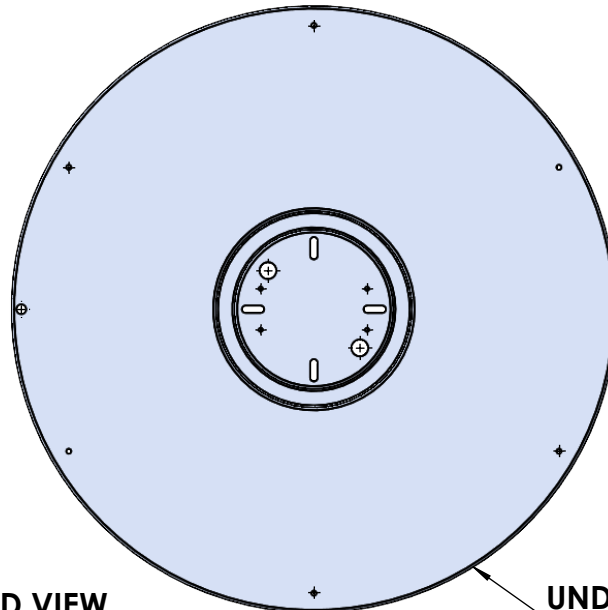
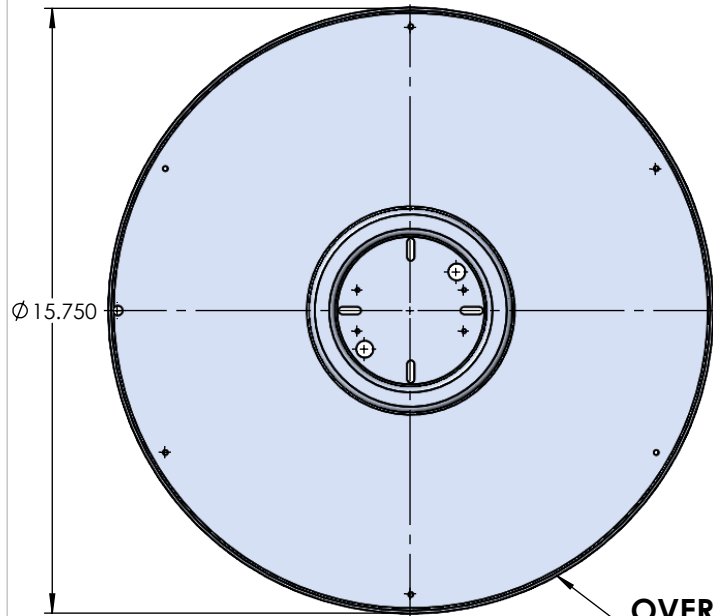
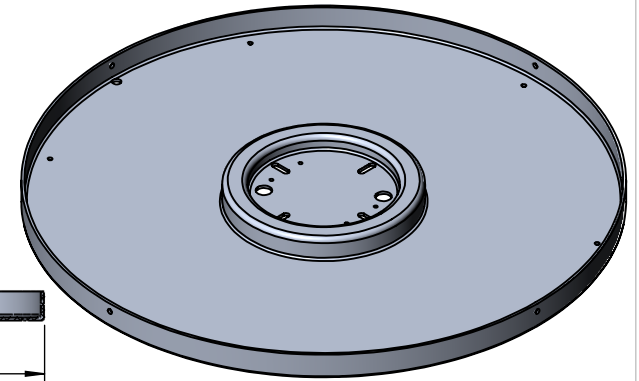
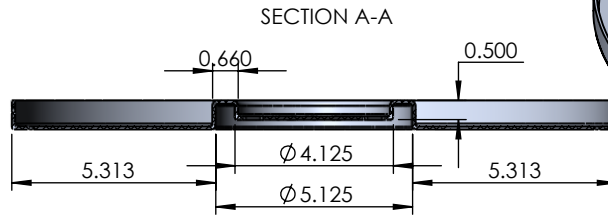
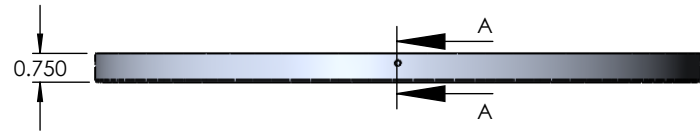

PROPRIETARY AND CONFIDENTIAL
 THE INFORMATION CONTAINED IN THIS DRAWING IS THE SOLE PROPERTY OF <INSERT COMPANY NAME HERE>. ANY REPRODUCTION IN PART OR AS A WHOLE WITHOUT THE WRITTEN PERMISSION OF <INSERT COMPANY NAME HERE> IS PROHIBITED.

		UNLESS OTHERWISE SPECIFIED:	NAME	DATE
		DIMENSIONS ARE IN INCHES	DRAWN	
		TOLERANCES:	CHECKED	
		FRACTIONAL ±	ENG APPR.	
		ANGULAR: MACH ± BEND ±	MFG APPR.	
		TWO PLACE DECIMAL ±	Q.A.	
		THREE PLACE DECIMAL ±	COMMENTS:	
		INTERPRET GEOMETRIC TOLERANCING PER:		
		MATERIAL		
NEXT ASSY	USED ON	FINISH		
APPLICATION		DO NOT SCALE DRAWING		

SPUN ALUMINUM 0.080"		
TITLE:		
STNLP-16"-24W-AA-A-XXK		
SIZE	DWG. NO.	REV
A		
SCALE: 1:5	WEIGHT:	SHEET 4 OF 12

ITEM NO.	PART NUMBER	DESCRIPTION	QTY.
1	STNLP-7"-10W-AA-A-XXK-SPUN BACKPAN	SPUN ALUMINUM 0.080"	1

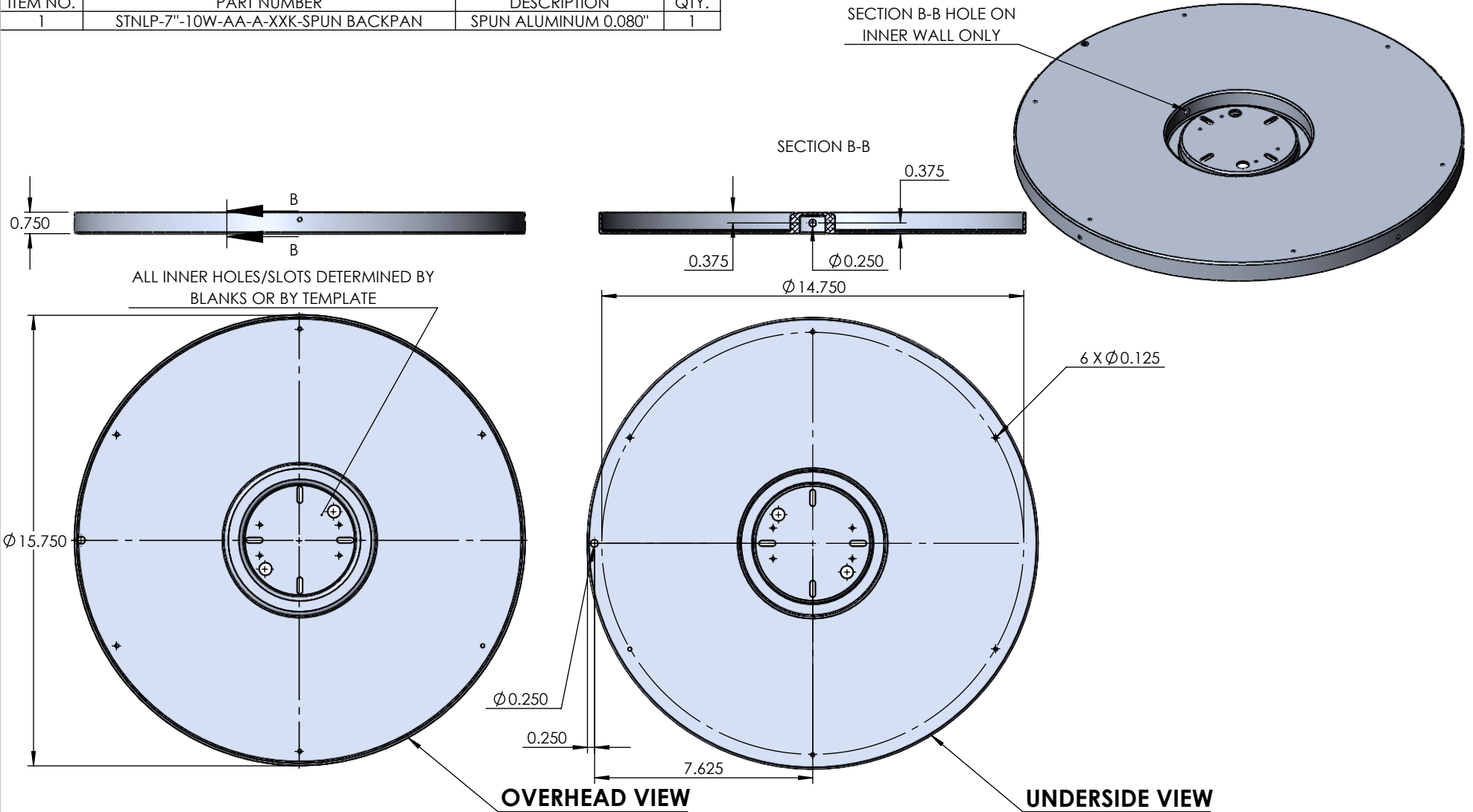

PROPRIETARY AND CONFIDENTIAL
 THE INFORMATION CONTAINED IN THIS DRAWING IS THE SOLE PROPERTY OF <INSERT COMPANY NAME HERE>. ANY REPRODUCTION IN PART OR AS A WHOLE WITHOUT THE WRITTEN PERMISSION OF <INSERT COMPANY NAME HERE> IS PROHIBITED.

		UNLESS OTHERWISE SPECIFIED:	NAME	DATE	SPUN ALUMINUM 0.080"	
		DIMENSIONS ARE IN INCHES	DRAWN		TITLE:	
		TOLERANCES:	CHECKED		STNLP-16"-24W-AA-A-XXK	
		FRACTIONAL ±	ENG APPR.		SIZE	DWG. NO.
		ANGULAR: MACH ± BEND ±	MFG APPR.		A	REV
		TWO PLACE DECIMAL ±	Q.A.		SCALE: 1:5	WEIGHT:
		THREE PLACE DECIMAL ±	COMMENTS:			SHEET 5 OF 12
NEXT ASSY	USED ON	INTERPRET GEOMETRIC TOLERANCING PER:				
		MATERIAL				
		FINISH				
APPLICATION		DO NOT SCALE DRAWING				

5

4

3

2

1

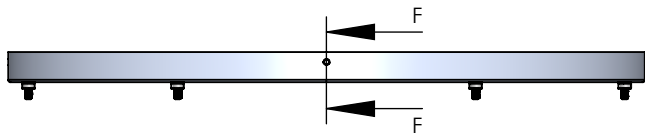
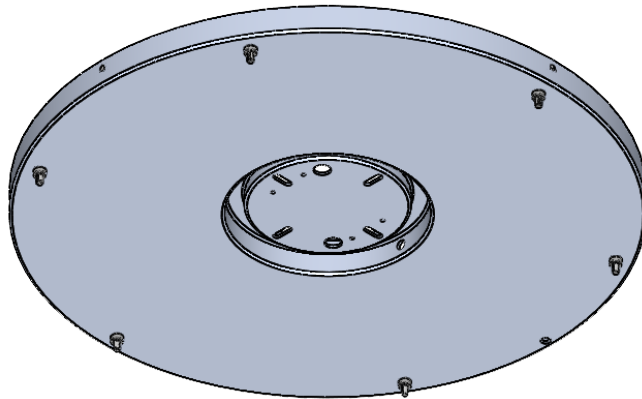
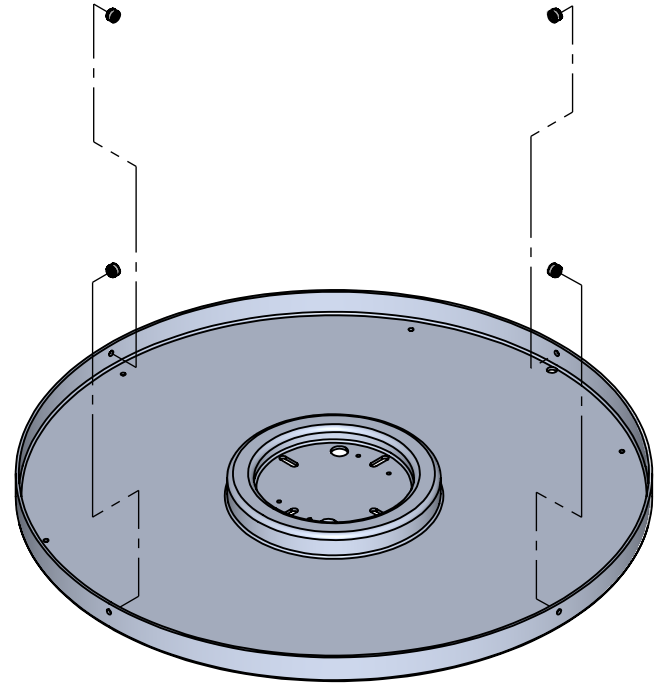
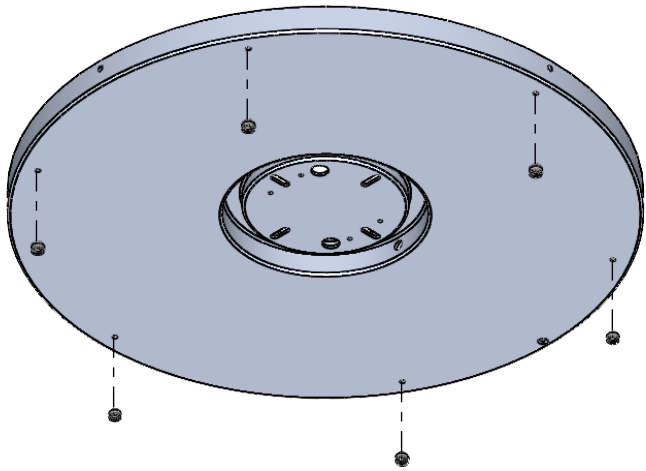

**PRESS FIT INSERTS WITH
1/4" THREADED STUD**

0.250

**PRESS FIT INSERTS FOR
SPUN COVER SCREWS**

SECTION F-F



ITEM NO.	PART NUMBER	DESCRIPTION	QTY.
1	STNLP-16"-24W-AA-A-XXK-SPUN COVER	SPUN ALUMINUM 0.080"	1

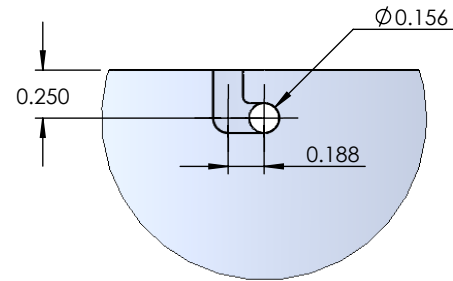
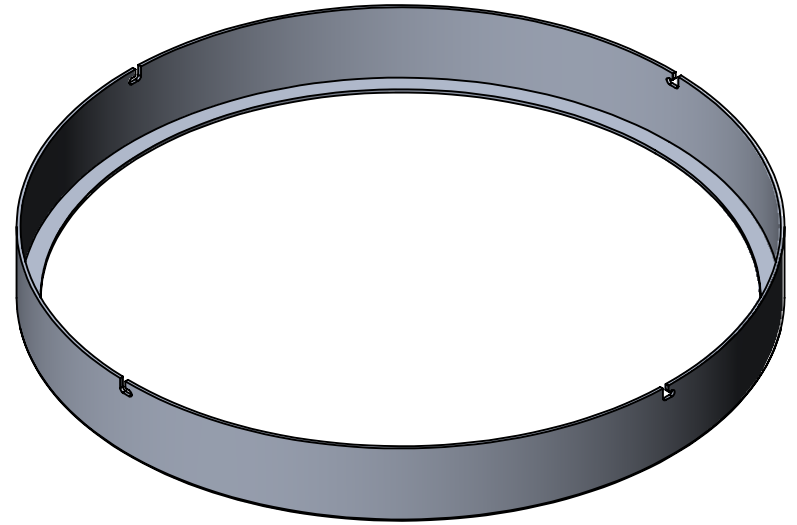
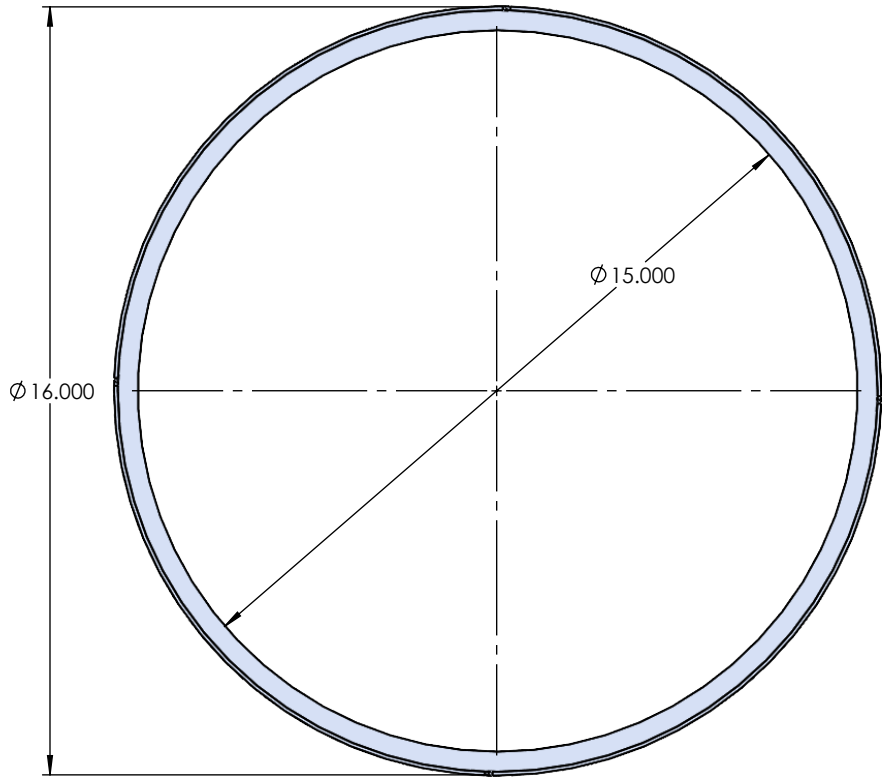
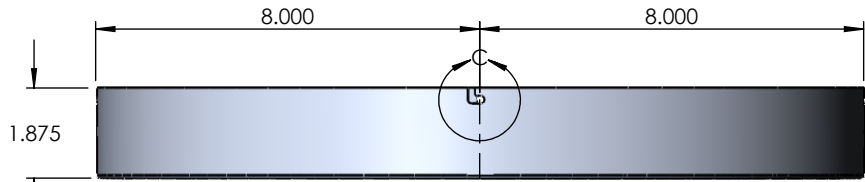

DETAIL C
SCALE 1 : 1

PROPRIETARY AND CONFIDENTIAL
THE INFORMATION CONTAINED IN THIS DRAWING IS THE SOLE PROPERTY OF <INSERT COMPANY NAME HERE>. ANY REPRODUCTION IN PART OR AS A WHOLE WITHOUT THE WRITTEN PERMISSION OF <INSERT COMPANY NAME HERE> IS PROHIBITED.

		UNLESS OTHERWISE SPECIFIED:	NAME	DATE
		DIMENSIONS ARE IN INCHES TOLERANCES: FRACTIONAL ± ANGULAR: MACH ± BEND ± TWO PLACE DECIMAL ± THREE PLACE DECIMAL ±	DRAWN	
		INTERPRET GEOMETRIC TOLERANCING PER:	CHECKED	
		MATERIAL	ENG APPR.	
		FINISH	MFG APPR.	
NEXT ASSY	USED ON		Q.A.	
APPLICATION	DO NOT SCALE DRAWING		COMMENTS:	

SPUN ALUMINUM 0.080"

TITLE:

STNLP-16"-24W-AA-A-XXK

SIZE	DWG. NO.	REV
A		

SCALE: 1:4 WEIGHT: SHEET 7 OF 12

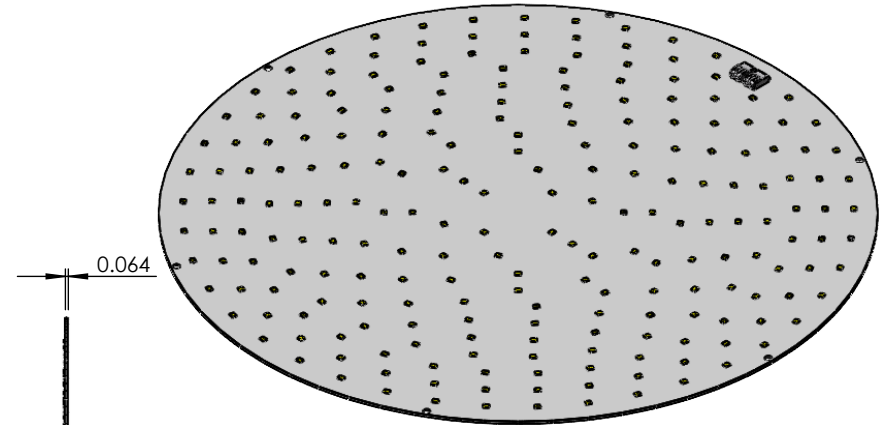
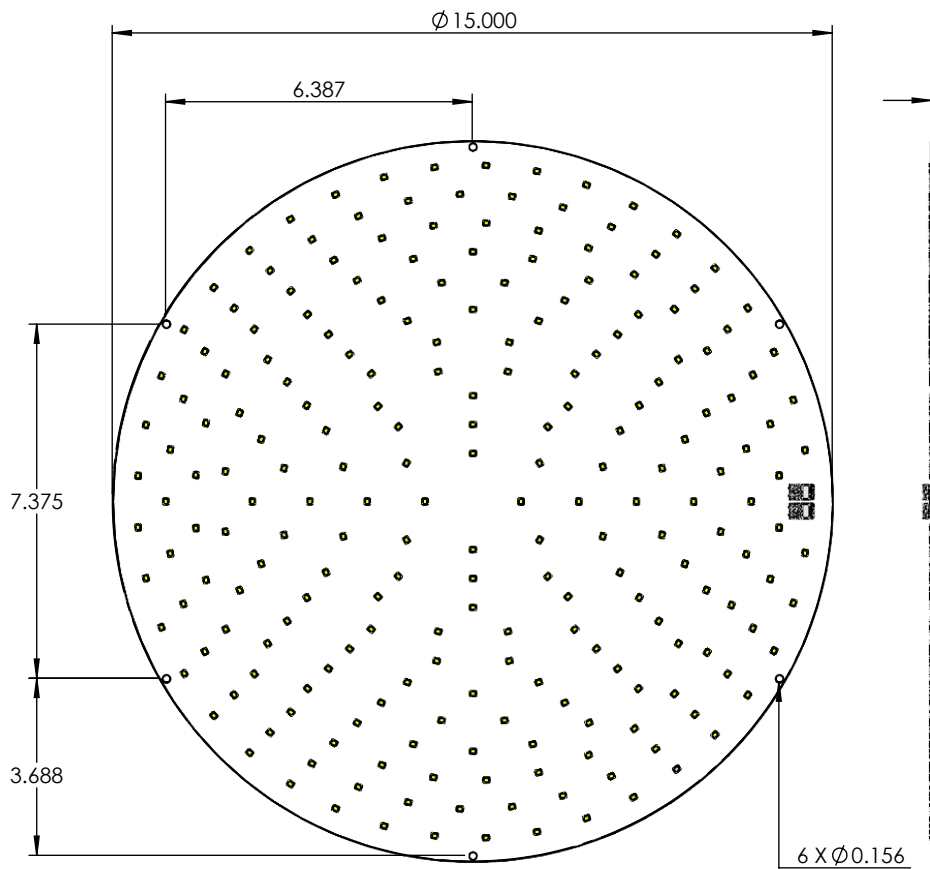

PROPRIETARY AND CONFIDENTIAL
 THE INFORMATION CONTAINED IN THIS DRAWING IS THE SOLE PROPERTY OF <INSERT COMPANY NAME HERE>. ANY REPRODUCTION IN PART OR AS A WHOLE WITHOUT THE WRITTEN PERMISSION OF <INSERT COMPANY NAME HERE> IS PROHIBITED.

		UNLESS OTHERWISE SPECIFIED:		NAME	DATE
		DIMENSIONS ARE IN INCHES	DRAWN		
		TOLERANCES:	CHECKED		
		FRACTIONAL \pm	ENG APPR.		
		ANGULAR: MACH \pm BEND \pm	MFG APPR.		
		TWO PLACE DECIMAL \pm	Q.A.		
		THREE PLACE DECIMAL \pm	COMMENTS:		
		INTERPRET GEOMETRIC TOLERANCING PER:			
		MATERIAL			
	NEXT ASSY	USED ON			
	APPLICATION	DO NOT SCALE DRAWING			

24-WATT LED PUCK		
TITLE:		
STNLP-16"-24W-AA-A-XXK		
SIZE	DWG. NO.	REV
A		
SCALE: 1:4	WEIGHT:	SHEET 8 OF 12

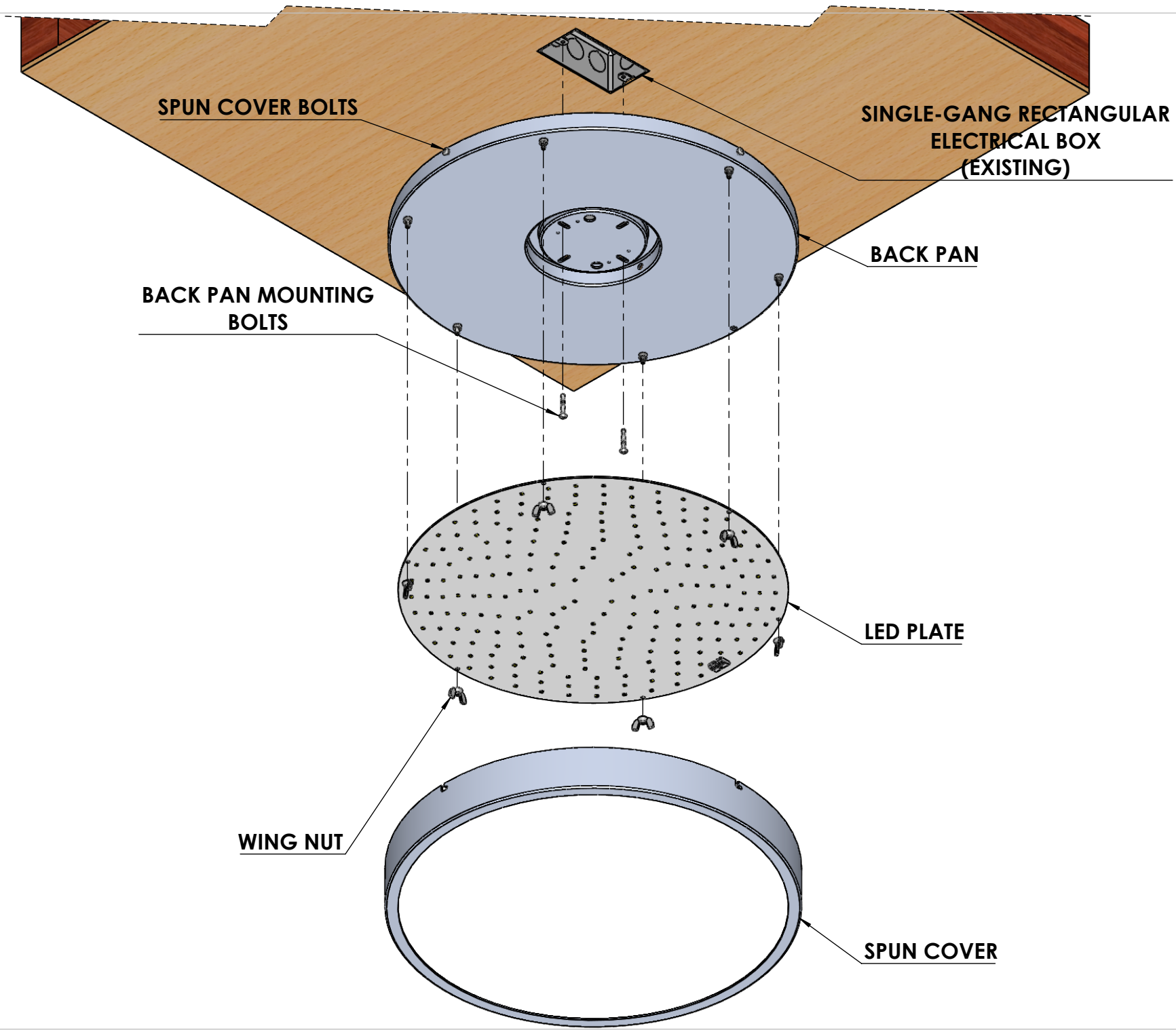

SPUN COVER BOLTS

**SINGLE-GANG RECTANGULAR
ELECTRICAL BOX
(EXISTING)**

BACK PAN

**BACK PAN MOUNTING
BOLTS**

LED PLATE

WING NUT

SPUN COVER

